

ENGINEERING SERVICES
EXAMINATION 2016

DO NOT OPEN THIS TEST BOOKLET UNTIL YOU ARE ASKED TO DO SO

T.B.C. : B-GTD-O-DDA

Test Booklet Series

Serial

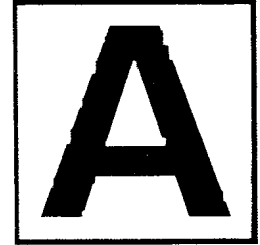

TEST BOOKLET
CIVIL ENGINEERING
Paper I

Time Allowed : Two Hours

Maximum Marks : 200

INSTRUCTIONS

1. IMMEDIATELY AFTER THE COMMENCEMENT OF THE EXAMINATION, YOU SHOULD CHECK THAT THIS TEST BOOKLET **DOES NOT** HAVE ANY UNPRINTED OR TORN OR MISSING PAGES OR ITEMS, ETC. IF SO, GET IT REPLACED BY A COMPLETE TEST BOOKLET.
2. Please note that it is the candidate's responsibility to encode and fill in the Roll Number and Test Booklet Series Code A, B, C or D carefully and without any omission or discrepancy at the appropriate places in the OMR Answer Sheet. Any omission/discrepancy will render the Answer Sheet liable for rejection.
3. You have to enter your Roll Number on the Test Booklet in the Box provided alongside. **DO NOT** write *anything else* on the Test Booklet.
4. This Test Booklet contains **120** items (questions). Each item comprises four responses (answers). You will select the response which you want to mark on the Answer Sheet. In case, you feel that there is more than one correct response, mark the response which you consider the best. In any case, choose **ONLY ONE** response for each item.
5. You have to mark all your responses **ONLY** on the separate Answer Sheet provided. See directions in the Answer Sheet.
6. All items carry equal marks.
7. Before you proceed to mark in the Answer Sheet the response to various items in the Test Booklet, you have to fill in some particulars in the Answer Sheet as per instructions sent to you with your Admission Certificate.
8. After you have completed filling in all your responses on the Answer Sheet and the examination has concluded, you should hand over to the Invigilator **only the Answer Sheet**. You are permitted to take away with you the Test Booklet.
9. Sheets for rough work are appended in the Test Booklet at the end.
10. **Penalty for wrong answers :**
THERE WILL BE PENALTY FOR WRONG ANSWERS MARKED BY A CANDIDATE.
 - (i) There are four alternatives for the answer to every question. For each question for which a wrong answer has been given by the candidate, **one-third (0.33)** of the marks assigned to that question will be deducted as penalty.
 - (ii) If a candidate gives more than one answer, it will be treated as a **wrong answer** even if one of the given answers happens to be correct and there will be same penalty as above to that question.
 - (iii) If a question is left blank, i.e., no answer is given by the candidate, there will be **no penalty** for that question.

DO NOT OPEN THIS TEST BOOKLET UNTIL YOU ARE ASKED TO DO SO

1. One bag of Portland cement, 50 kg in weight, would normally have a bulk volume of
- 30 l
 - 35 l
 - 40 l
 - 45 l
2. AsCu, a preservative for wood, developed by the Forest Research Institute, Dehradun, comprises of chemicals :
 $As_2O_5 \cdot 2H_2O$, $CuSO_4 \cdot 5H_2O$ and $K_2Cr_2O_7$ in the proportion of
- 1 : 1 : 1
 - 1 : 2 : 3
 - 1 : 2 : 4
 - 1 : 3 : 4
3. The minimum number of annular rings to be seen in every 2.54 cm in the radial direction from the core for timber to be classified as 'Dense' is
- 10
 - 20
 - 25
 - 30
4. Consider the following statements related to autoclave bricks :
- Less water absorption compared to other bricks.
 - Noise reduction.
 - It is cheap compared to other types of bricks.
 - Requirement of bulk volume of mortar in joints being relatively less compared to other types of brick masonry.
 - Not recommended for outer walls.
- Which of the above statements are relevant to the use of 'autoclave' bricks ?
- 1, 2 and 4
 - 1, 3 and 5
 - 2, 3 and 4
 - 2, 4 and 5
5. If the actual thickness of a brick masonry wall is 19 cm, its effective length is 2.70 m, its effective height is 2.82 m and its code-specified stiffening coefficient is 1.2, then, for design considerations, the slenderness ratio of the wall will be taken as
- 11.8
 - 12.4
 - 14.2
 - 14.8
6. Consider the following forms of water in a hydrated cement paste :
- Capillary water
 - Chemically combined water
 - Interlayer water
 - Adsorbed water
- Which of the above forms of water will, on its/their removal, cause shrinkage of the paste ?
- 1, 2 and 3
 - 1, 2 and 4
 - 2, 3 and 4
 - 1, 3 and 4
7. A specimen is subjected to a pure shear stress regime of intensity τ . The resulting tensile and compressive stresses σ , which occur on planes inclined at 45° to the direction of the shear stresses, would be
- τ
 - $\frac{\tau}{2}$
 - $\sqrt{2} \tau$
 - $\frac{\tau}{\sqrt{2}}$

8. Consider the following statements :
High early strength of cement is obtained as a result of

1. Fine grinding.
2. Decreasing the lime content.
3. Burning at higher temperature.
4. Increasing the quantity of gypsum.

Which of the above statements are correct ?

- (a) 1 and 2
- (b) 1 and 3
- (c) 2 and 3
- (d) 3 and 4

9. Consider the following statements related to 'composite mortar' :

1. Addition of lime to cement mortar improves its workability.
2. Composite mortar is obtained by adding 10% by weight of cement and mixing with water.
3. Composite mortar is not preferred in tall buildings.
4. Mechanical grinding is essential for developing composite mortar.

Which of the above statements are true in this case ?

- (a) 1, 2 and 3 only
- (b) 1, 3 and 4 only
- (c) 2, 3 and 4 only
- (d) 1, 2, 3 and 4

10. Consider the following statements related to 'non-destructive testing' of concrete :

1. Indentation test is used to assess the quality of concrete.
2. Resonant Frequency Method is based on a laboratory test.
3. Compressive strength of concrete is estimated through Pulse Velocity Measurement.
4. Dynamic Modulus of Elasticity is determined by a Scnometer Test.
5. Thickness of concrete can be estimated by in-situ Rebound Hammer Test.

Which of the above statements are correct ?

- (a) 1, 2 and 3 only
- (b) 1, 2 and 5 only
- (c) 1, 2, 3 and 4 only
- (d) 1, 2, 3, 4 and 5

11. What is the amount of water required for a workable RC of max 1 : 2 : 4 by weight, when W/C is 0.60 and unit weight of concrete is 2400 kg/m^3 ?

- (a) 165 l
- (b) 205 l
- (c) 245 l
- (d) 285 l

12. For a given elastic material, the Elastic Modulus E is 210 GPa and its Poisson's Ratio is 0.27. What is the approximate value of its Modulus of Rigidity ?

- (a) 105 GPa
- (b) 83 GPa
- (c) 159 GPa
- (d) 165 GPa

13. A mild steel bar is subjected to an axial force P , resulting in an axial stress $\sigma_x = 100 \text{ N/mm}^2$. What would be the normal stress σ_n on a plane $n-n$ making an angle $\theta = 45^\circ$ with its axis?

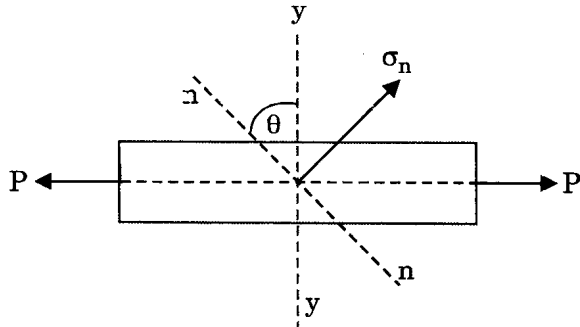

- (a) 25 N/mm^2
 (b) 40 N/mm^2
 (c) 50 N/mm^2
 (d) 100 N/mm^2
14. What is the ratio of the strain energy in bar X to that in bar Y when the material of the two bars is the same? The cross-sectional areas are as indicated over the indicated lengths.

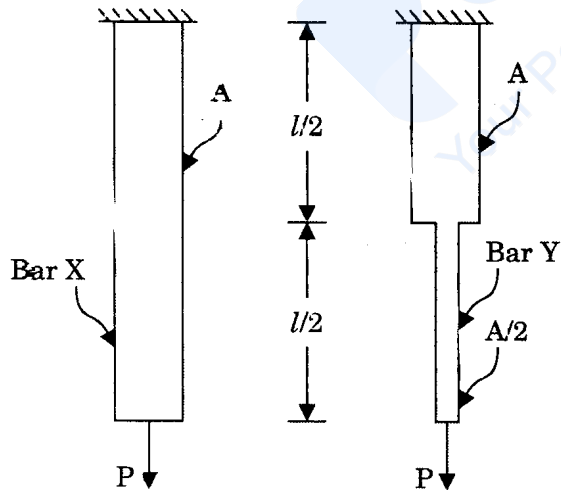

- (a) $1/3$
 (b) $2/3$
 (c) $4/3$
 (d) $1/6$

15. Which of the following stresses is measured on inclined surface in Mohr's Circle Method?

- (a) Principal stress
 (b) Normal stress
 (c) Tangential stress
 (d) Maximum stress

16. The state of stress on an element in plane stress is shown as in the figure.

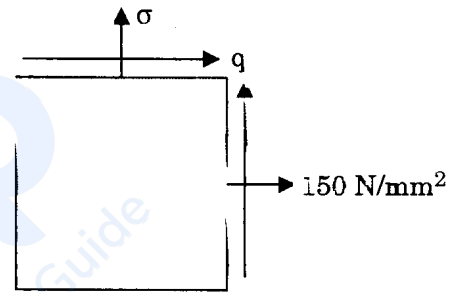

- What is the value of σ if the values of the principal stresses are 164 N/mm^2 and 36 N/mm^2 , both tensile?

- (a) 100 N/mm^2
 (b) 75 N/mm^2
 (c) 62.5 N/mm^2
 (d) 50 N/mm^2

17. Lead, as a material used in construction, has $E = 15 \text{ GPa}$ and $K = 50 \text{ GPa}$. What is its Poisson's Ratio?

- (a) 0.225
 (b) 0.30
 (c) 0.41
 (d) 0.45

18. For a block with Young's Modulus of its material being 210 GPa and its Poisson's Ratio being 0.25, when subjected to a stress system as shown in the figure, what is the magnitude of the stress σ for no strain along AB?

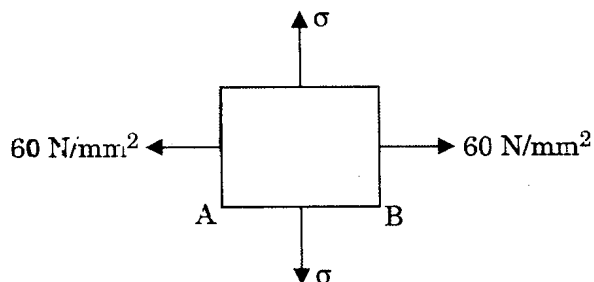

- (a) 30 N/mm²
 (b) 60 N/mm²
 (c) 120 N/mm²
 (d) 240 N/mm²
19. Two planks each of 50 mm × 50 mm section are glued together along the length to form a section 50 mm × 100 mm; and used as a beam. If the shear force at a section is 1000 N, what is the maximum shear stress on the glue?
- (a) 0.15 MPa
 (b) 0.3 MPa
 (c) 0.6 MPa
 (d) 2.4 MPa
20. The state of stress at a point in 2-D stress system is characterized by direct stresses of 40 MPa compressive and 80 MPa tensile, on mutually perpendicular planes. Shear stress is absent on these planes. The maximum shear stress at this point (along a duly identified plane) is
- (a) 20 MPa
 (b) 40 MPa
 (c) 60 MPa
 (d) 80 MPa

21. An electrical resistance strain rosette indicates strains of -400, +800 and +500 along the x, y and 45° axes. What is the shearing strain γ_{xy} ?

- (a) 100
 (b) 800
 (c) 600
 (d) -200

22. The biaxial stress system in an element is shown in the figure. Which of the following will give the normal stress in N/mm² in the plane BC making an angle of 45° with the plane BA?

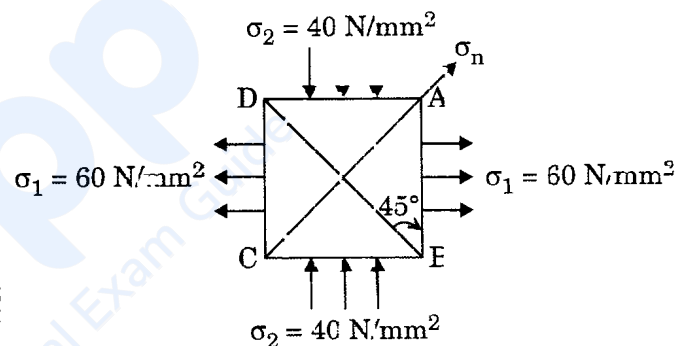

- (a) 25
 (b) 20
 (c) 15
 (d) 10

23. A cylindrical pressure vessel is 1200 mm in diameter. It is made of rolled mild steel plate. The vessel is subjected to an internal pressure of 2 N/mm². If the material yields at 200 N/mm², what should be the minimum safe thickness of the plate, based on Maximum Principal Stress Theory?

- (a) 18 mm
 (b) 15 mm
 (c) 12 mm
 (d) 9 mm

24. A machine element develops principal stresses of magnitudes $2P$ and P . What is the maximum magnitude of P before the material reaches the yield stress f_y as per Distortion Shear Energy Theory?
- f_y
 - $\frac{f_y}{2}$
 - $\frac{f_y}{2\sqrt{3}}$
 - $\frac{f_y}{\sqrt{3}}$
25. A structural element is subjected to a two-dimensional stress system, wherein $\sigma_1 = 225 \text{ N/mm}^2$ (tensile) with σ_2 being compressive. The yield stress in both simple tension $(\sigma_y)_t$ and simple compression $(\sigma_y)_c$ is 250 N/mm^2 and $\mu = 0.25$. What is the value of σ_2 , according to Maximum Strain Theory?
- 200 N/mm^2
 - 150 N/mm^2
 - 125 N/mm^2
 - 100 N/mm^2
26. A simply supported beam of length 4 m is subjected to a uniformly distributed load of 2 kN/m . What is the maximum shear stress if the cross-section is rectangular, 100 mm wide and 200 mm deep?
- 0.2 N/mm^2
 - 0.1 N/mm^2
 - 0.4 N/mm^2
 - 0.3 N/mm^2
27. A mild steel structural section is an unsymmetrical I-section, with the greater width at the top and the smaller width at the bottom. The overall depth of the beam is 300 mm , and the flange stresses at the top and the bottom of the beam are 150 N/mm^2 and 50 N/mm^2 respectively. What is the height of the neutral axis of the beam from its bottom?
- 125 mm
 - 100 mm
 - 75 mm
 - 50 mm
28. A circular shaft of diameter ' D ' is made of a material for which Young's Modulus of Elasticity is ' E ' and Poisson's Ratio is ' ν '. The ratio of flexural rigidity to torsional rigidity for the shaft is
- $4(1 + \nu)$
 - $1.5(1 - 2\nu)$
 - $(1 + \nu)$
 - $0.25(1 + \nu)$
29. A closely coiled helical spring of round steel wire 5 mm in diameter having 12 complete coils of 50 mm mean diameter is subjected to an axial load of 100 N . Modulus of Rigidity of the spring is 80 kN/mm^2 . What is the deflection of the spring?
- 12 mm
 - 24 mm
 - 36 mm
 - 48 mm
30. What is the shear stress at the neutral axis in a beam of isosceles triangular section with a base of 40 mm and height 20 mm subjected to a shear force of 5 kN ?
- 3 MPa
 - 6 MPa
 - 10 MPa
 - 20 MPa

31. A beam of square cross-section is placed such that its neutral axis coincides with its diagonal, and it is subjected to a shear force F . What is the ratio of the maximum shear stress to the shear stress at the neutral axis?

- (a) $9/8$
 (b) $8/9$
 (c) $7/8$
 (d) $3/7$

32. The intensity of u.d.l. which, when it acts over the entire span of 1 m of a cantilever beam of rectangular cross-section of width 100 mm and depth 200 mm, would produce a maximum shear stress of 1.5 N/mm^2 , is

- (a) 20 kN/m
 (b) 30 kN/m
 (c) 26.3 kN/m
 (d) 36.6 kN/m

33. A solid conical bar of circular cross-section is suspended vertically as shown in the figure. The diameter of the bar at the base, D , equals 100 mm and its length, L , is 0.5 m. If $E = 200 \text{ GN/m}^2$ and its weight per unit volume is 80 kN/m^3 , the elongation of the bar under self-weight is

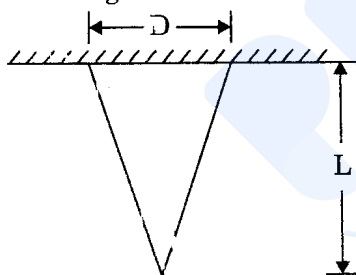

- (a) $1.50 \times 10^{-6} \text{ mm}$
 (b) $1.37 \times 10^{-5} \text{ mm}$
 (c) $1.71 \times 10^{-6} \text{ mm}$
 (d) $1.87 \times 10^{-5} \text{ mm}$

34. Two closely coiled helical springs A and B are equal in all respects but for the number of turns, with A having just half the number of turns of that of B. What is the ratio of deflections in terms of spring A to spring B?

- (a) $1/8$
 (b) $1/4$
 (c) $1/2$
 (d) $2/1$

35. What is the diameter c of a solid circular shaft when subjected to a torque T with a corresponding maximum shear stress of magnitude f_s ?

- (a) $\frac{16T}{\pi f_s}$
 (b) $\frac{\pi f_s}{16T}$
 (c) $\sqrt{\frac{16T}{\pi f_s}}$
 (d) $\sqrt[3]{\frac{16T}{\pi f_s}}$

36. A cubical element of a structural part made of mild steel is subjected to a tri-axial compressive stress as shown in the figure. The vertical compressive stress is σ_1 . The Modulus of Elasticity and Poisson's Ratio are E and μ , respectively. What should be the uniform lateral pressure σ_2 in terms of σ_1 and μ , so that lateral strain is prevented?

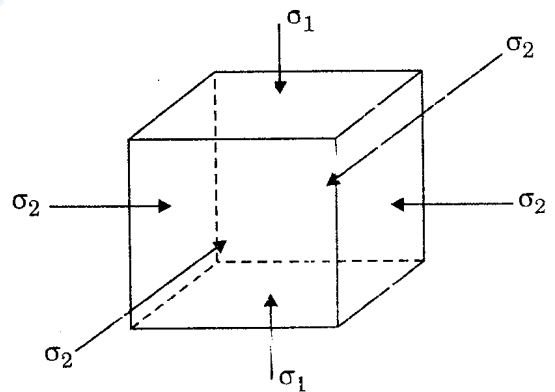

- (a) $\frac{\mu}{1-\mu} \sigma_1$
 (b) $\frac{\mu}{(1+\mu)(1-\mu)} \sigma_1$
 (c) $\frac{\mu}{1+\mu} \sigma_1$
 (d) $\frac{1+\mu}{1-\mu} \sigma_1$

37. A metal shaft of solid circular section rotates at 160 rpm and is subjected to a torque of 1500 Nm. What is the power, in kW, transmitted by the shaft?
- (a) 32π
 (b) 16π
 (c) 12π
 (d) 8π
38. What is the power transmitted by a 100 mm diameter solid shaft at 150 rpm without exceeding a maximum stress of 60 N/mm^2 ? Take $\pi^2 = 10$.
- (a) 187.5 kW
 (b) 18.75 kW
 (c) 1.875 kW
 (d) 1875 kW
39. What is the Polar Modulus of a solid circular metal shaft of diameter 8 cm?
- (a) $64\pi \text{ cm}^3$
 (b) $32\pi \text{ cm}^3$
 (c) $16\pi \text{ cm}^3$
 (d) $8\pi \text{ cm}^3$
40. A hollow circular shaft has the diameters 50 cm and 30 cm and is subjected to a torque. If the realized maximum shear stress is 30 N/mm^2 , what is the applied torque to nearest units?
- (a) 160 Nm
 (b) 320 Nm
 (c) 80 Nm
 (d) 32 Nm
41. Two simply supported beams are made up of the same material and are of the same cross-section. Both beams carry uniformly distributed loads of equal intensities. One beam is 2 m long and the other is 4 m long. The 2 m long beam shows a central deflection of 1 mm. What is the central deflection of the 4 m long beam?
- (a) 13 mm
 (b) 2 mm
 (c) 8 mm
 (d) 1 mm
42. A simply supported beam is subjected to a couple at a section within its span. It will produce
- SF diagram of zero magnitude.
 - Uniformly varying triangular BM diagram.
 - Sudden change in sign of BM at the point of application of the couple.
 - Equal and opposite reactions at supports.
- Which of the above statements are correct?
- (a) 1 and 2
 (b) 2 and 3
 (c) 3 and 4
 (d) 1 and 4
43. If the deflection at the free end of a uniformly loaded cantilever beam is 15 mm and the slope of the deflection curve at the free end is 0.02 radian, then the length of the beam is
- (a) 0.8 m
 (b) 1.0 m
 (c) 1.2 m
 (d) 1.5 m

44. A beam of overall length l , with equal overhangs on both sides, carries a uniformly distributed load over the entire length. To have numerically equal bending moments at the centre of the beam and at its supports, the distance between the supports should be

- (a) $0.277l$
- (b) $0.403l$
- (c) $0.586l$
- (d) $0.707l$

45. A single-bay single-storeyed portal frame ABCD is fixed at A and D as shown in the figure. If axial deformation is neglected, the kinematic indeterminacy is

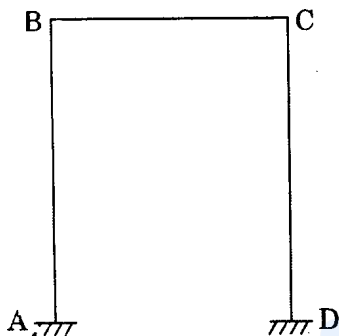

- (a) 3
- (b) 2
- (c) 6
- (d) 4

46. What is the number of kinematic indeterminacy for the building frame as shown in the figure when members are inextensible?

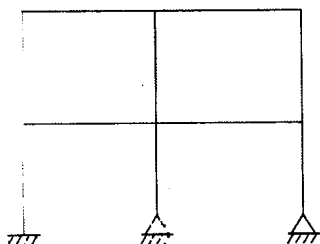

- (a) 3
- (b) 10
- (c) 12
- (d) 16

47. For the welded joint shown in the figure, the direct vertical shear stress on the weld is 40 MPa and the bending stress is 120 MPa . For what strength should the weld be designed?

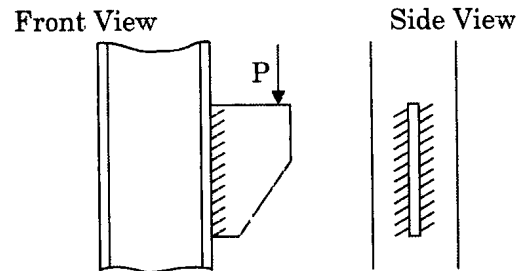

- (a) 80 MPa
- (b) 120 MPa
- (c) 132 MPa
- (d) 160 MPa

48. Degree of static indeterminacy of the structure as shown in the figure is

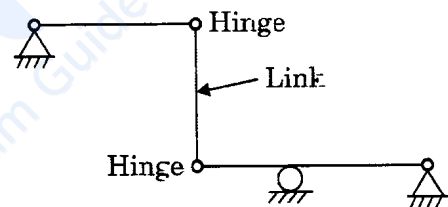

- (a) 0
- (b) 1
- (c) 2
- (d) 3

49. Which one of the following statements is correct for the pin-jointed truss shown in the figure?

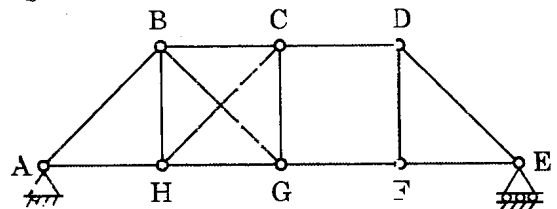

- (a) The truss is externally determinate but internally indeterminate
- (b) The truss is both externally and internally determinate
- (c) The truss is externally determinate and internally indeterminate and is unstable
- (d) The truss is externally determinate and internally indeterminate and is stable

50. Which one of the following methods is *not* classifiable as a Force Method?

- (a) The Theorem of Three Moments
- (b) The Moment Distribution Method
- (c) The Method of Consistent Deformation
- (d) Castigliano's Theorem

51. A cable of negligible weight is suspended between two points spaced 300 m apart horizontally, with the right support being 12 m higher than the left support. Four vertical loads of magnitudes 400, 200, 400 and 1200 kN are applied at points A, B, C and D which are 60, 120, 180 and 240 m horizontally respectively from the left support. The largest sag of the cable will be at

- (a) A
- (b) B
- (c) C
- (d) D

52. A single-bay portal frame of height h , fixed at the base, is subjected to a horizontal displacement δ at the top. The base moments developed are each proportional to

- (a) $\frac{1}{h}$
- (b) $\frac{1}{h^2}$
- (c) $\frac{1}{h^3}$
- (d) $\frac{1}{h^4}$

53. The total (both external and internal) degrees of indeterminacy of the pin-jointed structure shown in the figure is

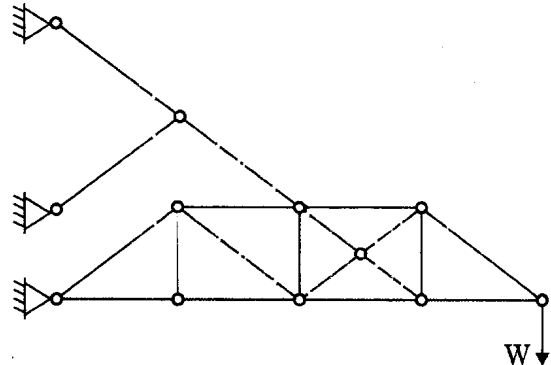

- (a) 4
- (b) 3
- (c) 2
- (d) 1

54. The bending moment diagram of a beam is shown in the figure.

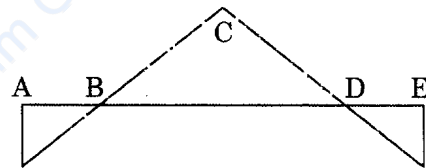

The shear force diagram of the beam is represented by

- (a)
- (b)
- (c)
- (d)

55. For the structure shown in the figure, all of I , EI and L are of respective unit values. The equivalent stiffness constant for the structure is

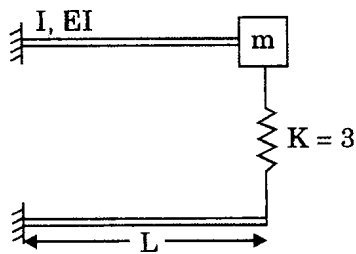

- (a) 1
 (b) 1.5
 (c) 4.5
 (d) 9
56. In considering Plastic Analysis, which of the following is a valid comprehensive statement?
- (a) Shape factor is the ratio of Plastic Section Modulus to the Elastic Section Modulus
 (b) Shape factor is the ratio of Elastic Section Modulus to the Plastic Section Modulus
 (c) Shape factor is the ratio of Plastic Section Modulus to the Elastic Section Modulus and its value is always greater than 1.0
 (d) Shape factor is the ratio of Elastic Section Modulus to the Plastic Section Modulus and its value is always less than 1.0
57. A fillet-welded joint is shown in the figure. The size of the weld is 8 mm. Safe stress in the weld is 110 N/mm^2 . What is the safe force (to the nearest magnitude) to which the weld can be subjected?

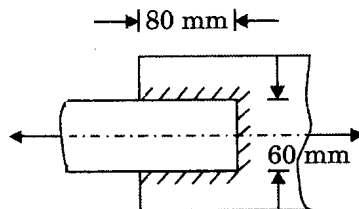

- (a) 125 kN
 (b) 130 kN
 (c) 140 kN
 (d) 135 kN

58. A circular shaft of diameter 120 mm is welded to a rigid plate by a fillet weld of size 6 mm. If a torque of 8 kNm is applied to the shaft, what is the maximum stress in the weld (to the nearest unit)?

- (a) 34 N/mm^2
 (b) 37 N/mm^2
 (c) 90 N/mm^2
 (d) 95 N/mm^2

59. Two plates of dimensions $150 \text{ mm} \times 16 \text{ mm}$ and $150 \text{ mm} \times 12 \text{ mm}$ at their welding edges are joined by butt welding as shown in the figure. What is the maximum tension that this single V-butt weld joint can transmit? The permissible tensile stress in the plates is 150 MPa.

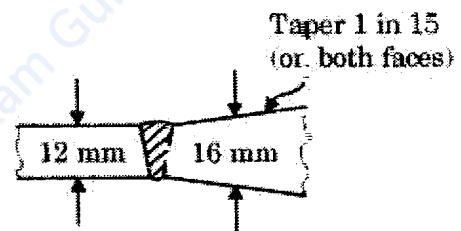

- (a) 168.75 kN
 (b) 270 kN
 (c) 218 kN
 (d) 1350 kN

60. A solid shaft transmits 150 kW at a shear stress of 70 MPa running at a frequency of 3 Hz. What will be the shear stress when the frequency is 1.5 Hz?

- (a) 35 MPa
 (b) 50 MPa
 (c) 57 MPa
 (d) 140 MPa

61. What is the maximum number of 20 mm diameter bolts that can be accommodated in a single row on a 140 mm wide flat strip used as one of the structural elements involved in the process ?

- (a) 4
- (b) 3
- (c) 2
- (d) 5

62. What is the nearest magnitude of strength of a 3 mm fillet weld of 100 mm length made between two flats each 10 mm thick ? The allowable shear stress on the weld is 110 MPa.

- (a) 23 kN
- (b) 33 kN
- (c) 46 kN
- (d) 66 kN

63. Consider the following statements :

1. The thickness of the gusset plate should not be more than the thickness of the structural members being connected.
2. A plate girder is essentially a beam and its moment of resistance depends upon its section modulus.
3. The function of the flanges in a plate girder is to resist the bending moment and hence their respective areas can be reduced near the supports of a simply supported beam.

Which of the above statements are correct ?

- (a) 1 and 2 only
- (b) 1 and 3 only
- (c) 2 and 3 only
- (d) 1, 2 and 3

64. Consider the following statements :

In a plate girder

1. Bearing stiffeners are designed for bearing forces and they must also be checked for safety against compressive forces.
2. The length of any staggered intermittent fillet weld should not be less than 10 times the thickness of the stiffener.
3. Bearing stiffeners must be provided at the point of maximum bending moment.

Which of the above statements are correct ?

- (a) 1 and 3 only
- (b) 2 and 3 only
- (c) 1 and 2 only
- (d) 1, 2 and 3

65. Consider the following statements :

Secondary stresses are induced in a roof truss due to

1. Purlins placed at intermediate points on panel lengths.
2. Rigidity of joints.
3. Eccentricity of the bolt line relative to the centroid of the member.

Which of the above statements are correct ?

- (a) 1 and 2 only
- (b) 1 and 3 only
- (c) 2 and 3 only
- (d) 1, 2 and 3

66. In the case of an axially loaded column, machined for full bearing, the fastenings connecting the column to the base plates through gussets are to be designed for

- (a) 100% of the load on the column
- (b) 50% of the load on the column
- (c) 25% of the load on the column
- (d) Respective erection conditions only

67. Consider the following statements :

1. When analyzing by the Ultimate Load Method, the eccentrically loaded fastener group rotates about an instantaneous centre.
2. The rivet which is the farthest from the centre of gravity of the rivet group and may also be the nearest to the applied load line is the most 'critical' one.
3. The deformation at each rivet is not proportional to its distance from the centre of rotation.

Which of the above statements are correct ?

- (a) 1 and 3 only
- (b) 2 and 3 only
- (c) 1 and 2 only
- (d) 1, 2 and 3

68. For a reinforced concrete beam with M 20 concrete with Fe 415 steel, the working moment corresponding to 'balanced failure' by the Limit State Method of Design is A times of the relatable magnitude of the working moment computed by the Working Stress Method. This value of A is nearly

- (a) 1.0
- (b) 1.5
- (c) 2.0
- (d) 2.5

69. A singly reinforced rectangular concrete beam has a width of 150 mm and an effective depth of 330 mm. The characteristic compressive strength of concrete is 20 MPa and the tensile strength of steel is 415 MPa. Adopt the stress block for concrete as per IS 456 - 2000 and take the limiting value of depth of neutral axis as 0.48 times the effective depth of the beam for considering as a balanced section. What is the likely approximation for the limiting value of the moment of resistance of the beam ?

- (a) 15 kNm
- (b) 25 kNm
- (c) 45 kNm
- (d) 75 kNm

70. If the stirrup spacing is equal to 0.75 times the effective depth of an RC beam, then the shear capacity of stirrup steel is equal to

- (a) $1.25 (f_y A_{sv})$
- (b) $1.16 (f_y A_{sv})$
- (c) $1.00 (f_y A_{sv})$
- (d) $0.80 (f_y A_{sv})$

where f_y is yield strength and A_{sv} is cross-sectional area of the stirrup steel.

71. A concrete column carries an axial load of 450 kN and a bending moment of 60 kNm at its base. An isolated footing of size 2 m × 3 m with the 3 m side along the plane of the bending moment is provided under the column. Centres of gravity of the column and the footing coincide. The net maximum and minimum pressures, in kPa, on the soil under the footing are, respectively

- (a) 95 and 75
- (b) 75 and 55
- (c) 95 and 55
- (d) 75 and 75

72. Carry-over factor at a support/end is defined as

- (a) Modulus of Elasticity EI
- (b) The ratio of moment produced at the far end to the applied moment at that support end
- (c) The value of the moment to be applied to that end to cause a local slope of one radian
- (d) 2 EK

73. What is the pH value of potable water, as specified by IS 456 - 2000 ?

- (a) Equal to 7
- (b) Between 6 and 9
- (c) Less than 6
- (d) Not less than 6

74. A certain RC structure has to be constructed along a sea coast. The minimum grade of concrete to be used as per IS 456 – 2000 is
- More than M 20
 - More than M 20 and less than M 30
 - Not less than M 30
 - Less than M 45 and more than M 30
75. What is the minimum area of tension reinforcement in beams when Fe 415 is used ?
- 0.8%
 - 0.12%
 - 0.15%
 - 0.2%
76. If a 2-legged 8 mm diameter HYSD bar is used as shear reinforcement for a beam of width 230 mm and effective depth 300 mm, what is the nearest magnitude of the spacing of minimum shear reinforcement ?
- 420 mm
 - 390 mm
 - 350 mm
 - 320 mm
77. Web buckling occurs in a beam due to excessive
- Direct tensile stress in the web
 - Bending tensile stress in the web
 - Torsional shear stress in the web
 - Compressive stress in the web
78. Which of the following statements are correct in respect of welded connections ?
- Strength of Butt weld is equal to the strength of components joined.
 - Fillet welds carry the loads computed based on the tensile strength characteristics of fusion material.
 - For effective transmission of load by fillet weld, the fusion faces shall subtend an angle between 60° and 120° .
- 1, 2 and 3
 - 1 and 2 only
 - 2 and 3 only
 - 1 and 3 only
79. A post-tensioned beam of span 25 m is prestressed with 20 numbers of 40 mm diameter cables, each stressed to 1500 MPa, with eccentricity $e = 0$ at supports and $e = 500$ mm at midspan, varying parabolically. If the shear force at the support section due to externally applied load is 4500 kN, what is the nearest magnitude of the shear force resisted by the stirrups ?
- 3060 kN
 - 4540 kN
 - 250 kN
 - 1480 kN
80. For a pre-tensioned beam, Young's Modulus of steel and concrete are 200 GPa and 35.35 GPa, respectively. If the ultimate shrinkage strain and Ultimate Creep Coefficient are 200 microns and 1.6, respectively, what is the level of sustained stress in concrete at the level of 'steel' if the loss due to creep is three times the loss due to shrinkage ?
- 9 MPa
 - 13 MPa
 - 11 MPa
 - 15 MPa

81. Consider the following statements :

Correct estimation of loss of prestress is required for assessing

1. The serviceability behaviour of a PSC beam.
2. The ultimate shear resistance of a PSC beam.
3. The ultimate moment of resistance of a PSC beam.

Which of the above statements is/are correct ?

- (a) 1, 2 and 3
- (b) 3 only
- (c) 2 only
- (d) 1 only

82. Which of the following statements are correct in case of vertical intermediate stiffeners ?

1. These are required only when the ratio of web depth to thickness is greater than 150.
2. They should be provided throughout the length of beam at spacing less than 1.5 times web depth.
3. These can be fitted between flanges with clear gaps at top and bottom.

- (a) 1 and 2 only
- (b) 2 and 3 only
- (c) 1 and 3 only
- (d) 1, 2 and 3

83. The relation between the strength of brick masonry f_w , the strength of bricks f_b , and the strength of mortar f_m is given by (where K_w is a coefficient based on the layout of the bricks and the joints)

- (a) $f_w = \sqrt{K_w \frac{f_b}{f_m}}$
- (b) $f_w = K_w \sqrt{\frac{f_b}{f_m}}$
- (c) $f_w = \sqrt{K_w f_b f_m}$
- (d) $f_w = K_w \sqrt{f_b f_m}$

84. As per IS 3102 - 1965, for F1 class bricks, the percentage water absorption after 24 hrs of immersion in cold water shall *not* exceed

- (a) 20%
- (b) 12%
- (c) 25%
- (d) 5%

85. The effective height of a masonry wall of height H restrained fully at its top and partially at its bottom is

- (a) 0.75 H
- (b) 0.85 H
- (c) 1.00 H
- (d) 1.50 H

86. The effective length of a masonry wall stiffened by buttresses on both ends and continuing beyond these buttresses at both ends is

- (a) 1.0 L
- (b) 2.0 L
- (c) 0.9 L
- (d) 0.8 L

where L is the c/c length of the wall between successive buttresses.

87. A wall carries an axial load, 12 kN/m and also an eccentric load of 27 kN/m at 72 mm from the central axis of the wall. The equivalent eccentricity e is nearly

- (a) 65 mm
- (b) 60 mm
- (c) 55 mm
- (d) 50 mm

88. A shear wall of length 5 m, height 3 m and thickness 250 mm has to resist the forces due to horizontal earthquake in its plane. The relevant Section Modulus of the wall section is

- (a) $3.75 \times 10^8 \text{ mm}^3$
- (b) $10.41 \times 10^8 \text{ mm}^3$
- (c) $31.25 \times 10^6 \text{ mm}^3$
- (d) $75 \times 10^3 \text{ mm}^3$

88. In reinforced brickwork slabs, the diameter of main reinforcement shall, preferably **not** exceed

- (a) 8 mm
- (b) 10 mm
- (c) 12 mm
- (d) 16 mm

90. Consider two RCC beams, P and Q, each of width 400 mm and effective depth 750 mm, made with concrete having a $\tau_{c \max} = 2.0$ MPa. For the reinforcement provided and the grade of concrete used, it may be assumed that $\tau_{c \max} = 0.75$ MPa. If the design shear for the beams P and Q is 400 kN and 750 kN, respectively, which of the following statements is true considering the provisions of IS 456 - 2000 ?

- (a) Shear reinforcement should be designed for 175 kN for beam P and the section for beam Q should be revised
- (b) Nominal shear reinforcement is required for beam P and the shear reinforcement should be designed for 120 kN for beam Q
- (c) Shear reinforcement should be designed for 175 kN for beam P and the section for beam Q should be designed for 525 kN for beam Q
- (d) The sections for both beams, P and Q, need to be revised

91. The minimum strain at failure in tension steel having yield stress $f_y = 415$ MPa and Young's Modulus $E_s = 200$ GPa, as per Limit State Method of Design, is

- (a) 0.0025
- (b) 0.0038
- (c) 0.0045
- (d) 0.0050

92. Which one of the following Mohr's Circles represents the state of pure shear ?

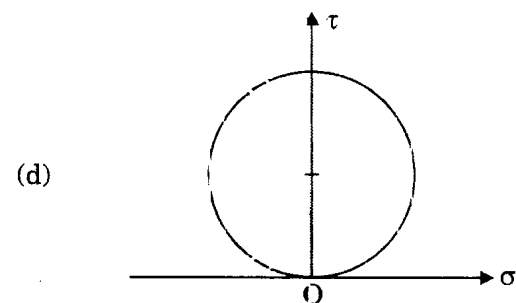
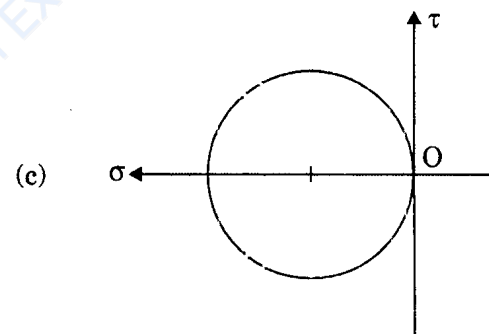
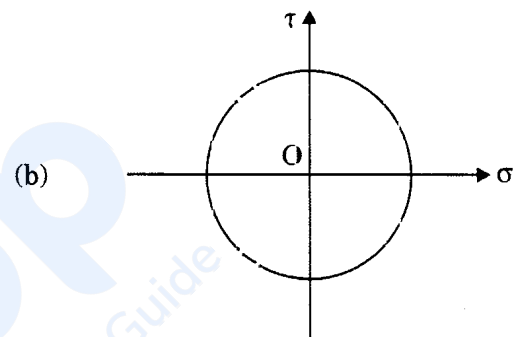
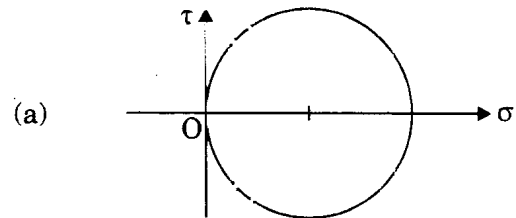

93. Activity A, Activity B and Activity C are cast into a ladder diagrammatic CPM network, with splitting each into three equal parts as A_1, A_2, A_3 ; and B_1, B_2, B_3 ; and C_1, C_2, C_3 . Typical sequencing as in a ladder diagram is adopted (like B_2 following A_2 and B_1). The optimum number of dummy arrows needed for a satisfactory and correct ladder diagram will be

- (a) 1
- (b) 2
- (c) 3
- (d) 4

94. A mechanism shown in the figure consists of equally long steel and copper wires which carry the applied load in equal shares. What shall be the ratio of the diameter of the copper wire to that of the steel wire, when both the wires undergo equal strains?

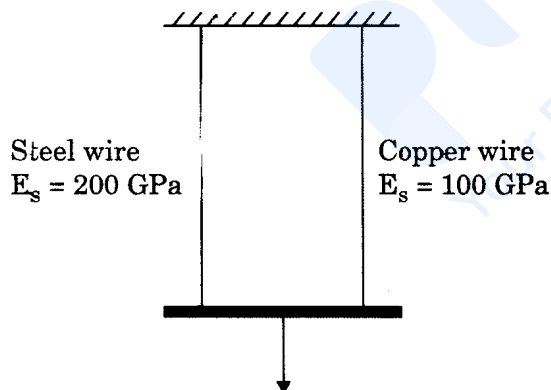

- (a) $\sqrt{2}$
- (b) 1.0
- (c) $\frac{1}{\sqrt{2}}$
- (d) $\frac{1}{2}$

95. Consider the following related to sand in mortars:

1. It increases the volume of the mortar mix.
2. It increases the strength of masonry.
3. The cost of the mortar is reduced.
4. Shrinkage of the mortar is almost prevented.
5. Surkhi can replace sand in cement mortar used in plastering and this modified mortar is more durable.

Which of the above are relevant to 'sand' in mortar?

- (a) 1, 2, 4 and 5
- (b) 1, 3 and 4 only
- (c) 3, 4 and 5 only
- (d) 2, 3 and 4 only

96. In a concrete mix, if the maximum size of coarse aggregate is increased, the proportion of fine to coarse aggregate should be

- (a) Increased
- (b) Decreased
- (c) Kept the same
- (d) Not dependent on size of aggregates

97. It is estimated that an activity can be assigned an optimistic duration of 16 days, a pessimistic duration of 28 days and a most likely duration of 19 days. What is the expected duration for this activity?

- (a) 20 days
- (b) 19 days
- (c) 22 days
- (d) 18 days

98. Consider the following statements :

1. Modulus of Elasticity of concrete increases with increase in compressive strength of concrete.
2. Brittleness of concrete increases with decrease in compressive strength of concrete.
3. Shear strength of concrete increases with increase in compressive strength of concrete.

Which of the above statements are correct ?

- (a) 1 and 2 only
- (b) 1, 2 and 3
- (c) 1 and 3 only
- (d) 2 and 3 only

99. A three-hinged parabolic arch of span ' l ' and rise ' h ' is subjected to a u.d.l. of intensity ' ω '; then the horizontal thrust at the supports is

- (a) $\frac{\omega l^2}{8 h}$
- (b) $\frac{\omega l}{h}$
- (c) $\frac{\omega l}{8 h^2}$
- (d) $\frac{\omega h l}{8}$

100. A rectangular beam of width 230 mm and effective depth 300 mm is proposed to carry a BM and SF of 120 kNm and 270 kN, respectively. If M 30 grade of concrete and Fe 415 steel are used for which $\tau_{c \max} = 3.5$ MPa, which one of the following statements is correct ?

- (a) It can be designed as a singly reinforced, under-reinforced section
- (b) It can be designed as a doubly reinforced section
- (c) The section is unsafe from shear considerations
- (d) It can be designed as a doubly reinforced section but it is unsafe from shear considerations

Directions : Each of the next twenty (20) items consists of two statements, one labelled as the 'Statement (I)' and the other as 'Statement (II)'. You are to examine these two statements carefully and select the answers to these items using the codes given below :

Codes :

- (a) Both Statement (I) and Statement (II) are individually true and Statement (II) is the correct explanation of Statement (I)
- (b) Both Statement (I) and Statement (II) are individually true but Statement (II) is **not** the correct explanation of Statement (I)
- (c) Statement (I) is true but Statement (II) is false
- (d) Statement (I) is false but Statement (II) is true

101. *Statement (I) :*

Timber suitable for furniture is obtained from conifers only.

Statement (II) :

Woods with distinct annual rings are conifers.

102. *Statement (I) :*

Seasoning of timber gives dimensional stability, safety against attack by fungi and improved workability.

Statement (II) :

Seasoning of timber removes moisture in the form of sap from timber.

103. *Statement (I) :*

Strength of brick wall is dependent on the type of bricks and the mortar used.

Statement (II) :

Slenderness ratio of masonry decides the strength of the wall, and also mortar type to be used.

104. *Statement (I) :*

Fly ash bricks are used in construction as alternatives to burnt clay bricks.

Statement (II) :

Fly ash bricks are lighter in weight and are stronger than burnt clay bricks.

105. *Statement (I) :*

Air-entraining cement has a higher initial setting time than o.p.c. and resists frost action better.

Statement (II) :

Air-entraining cement has a longer final setting time compared to o.p.c.

106. *Statement (I) :*

A merging node will have a uniquely determinable Late Event Time.

Statement (II) :

A merging node is defined as a node where more than one incoming activity arrow leads in.

107. *Statement (I) :*

Deadweight of a structure can be reduced by using light weight concrete in construction.

Statement (II) :

Aerated concrete, being of light weight, is used in R.C.C. multi-storied construction.

108. *Statement (I) :*

Admixture in concrete is an essential constituent of concrete.

Statement (II) :

Admixture helps in improving or modifying specific qualities in concrete.

109. *Statement (I) :*

The failure surface of an axially loaded mild steel tension specimen of circular cross-section is along a plane at 45° to the axis of the specimen.

Statement (II) :

The failure occurs on a plane of the specimen subjected to maximum shear stress and mild steel is relatively weak in shear.

110. *Statement (I) :*

In pin-jointed roof trusses, purlins are kept above nodes in the top chord.

Statement (II) :

The top chord is continuous through the nodes of the truss.

111. *Statement (I) :*

Repeated passes are needed with sheep-foot rollers for optimum compaction.

Statement (II) :

Even if optimum moisture content is ensured, repeated passes are needed to ensure right and even distribution of moisture within the soil volume.

112. *Statement (I) :*

Dewatering pumps for use in shallow pits are often of nearly straight-blade centrifugal types.

Statement (II) :

Centrifugal pumps can lift water to high lifts.

113. *Statement (I) :*

Crawler-mounted excavator is more suitable for excavation in soft ground.

Statement (II) :

Crawler-mounted excavator can be moved at low speeds.

114. Statement (I) :

In a project involving construction of several self-similar multi-storey houses, the Scheduled Bar Chart is best converted into Lines of Balance Diagram — which yet remains a 'Stacked' Bar Chart.

Statement (II) :

It is necessary to ensure that no set of Lines of Balance slope forward in time, from last block to first block, or top to bottom.

115. Statement (I) :

At positions of curtailment of flange plates in a built-up structure, web stiffeners are also necessarily to be provided.

Statement (II) :

This improves the architectural beauty of the structure

116. Statement (I) :

ACN networks do not generally have any dummy links.

Statement (II) :

Links express activity dependencies exhaustively and completely.

117. Statement (I) :

'Lift' and 'lead', even if wherever relevant, do not affect any activity duration during the course of implementation of a project.

Statement (II) :

Procurement of materials, particularly, is normally from assigned, or designated, quarry sites, which are already fixed while starting the project.

118. Statement (I) :

Time-Cost Study for a project must be adopted only when project duration is to be crashed.

Statement (II) :

When there are unmanageable restrictions in realizing a predetermined resource histogram Time-Cost Study may have to consider extension of project duration as well

119. Statement (I) :

Activity streams along a component Work-Breakdown Structure along a sub-path can refer also to an auxiliary Work-Breakdown Structure considered vertically in segments of adjacent sub-paths.

Statement (II) :

Work-Breakdown Structures refer to a single sub-path with a progressive duration along the activity arrows.

120. Statement (I) :

In a multi-path PERT network, the project duration resulting from the critical path always has a 50% probability of completion by that duration.

Statement (II) :

The expected through-path duration together with 3-times the standard deviation of that expected duration must be considered for all the paths in the network

SPACE FOR ROUGH WORK

prepp
Your Personal Exam Guide

SPACE FOR ROUGH WORK

prepp
Your Personal Exam Guide

SPACE FOR ROUGH WORK

Prepp
Your Personal Exam Guide

SPACE FOR ROUGH WORK

prepp
Your Personal Exam Guide