

ENGINEERING SERVICES  
 EXAMINATION-2014

---

 DO NOT OPEN THIS TEST BOOKLET UNTIL YOU ARE ASKED TO DO SO
 

---

T.B.C. : B-DMHH-N-FUB

Test Booklet Series

Serial

88805

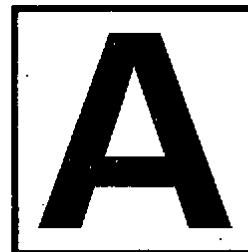

## TEST BOOKLET

## ELECTRONICS &amp; TELECOMMUNICATION ENGINEERING

## Paper II

---

 Time Allowed : Two Hours

 Maximum Marks : 200
 

---

## INSTRUCTIONS

1. IMMEDIATELY AFTER THE COMMENCEMENT OF THE EXAMINATION, YOU SHOULD CHECK THAT THIS TEST BOOKLET DOES **NOT** HAVE ANY UNPRINTED OR TORN OR MISSING PAGES OR ITEMS, ETC. IF SO, GET IT REPLACED BY A COMPLETE TEST BOOKLET.
2. Please note that it is the candidate's responsibility to encode and fill in the Roll Number and Test Booklet Series Code A, B, C or D carefully and without any omission or discrepancy at the appropriate places in the OMR Answer Sheet. Any omission/discrepancy will render the Answer Sheet liable for rejection.
3. You have to enter your Roll Number on the Test Booklet in the Box provided alongside.   
**DO NOT** write *anything else* on the Test Booklet.
4. This Test Booklet contains **120** items (questions). Each item comprises four responses (answers). You will select the response which you want to mark on the Answer Sheet. In case you feel that there is more than one correct response, mark the response which you consider the best. In any case, choose **ONLY ONE** response for each item.
5. You have to mark all your responses **ONLY** on the separate Answer Sheet provided. See directions in the Answer Sheet.
6. All items carry equal marks.
7. Before you proceed to mark in the Answer Sheet the response to various items in the Test Booklet, you have to fill in some particulars in the Answer Sheet as per instructions sent to you with your Admission Certificate.
8. After you have completed filling in all your responses on the Answer Sheet and the examination has concluded, you should hand over to the Invigilator **only the Answer Sheet**. You are permitted to take away with you the Test Booklet.
9. Sheets for rough work are appended in the Test Booklet at the end.
10. **Penalty for wrong answers :**  
**THERE WILL BE PENALTY FOR WRONG ANSWERS MARKED BY A CANDIDATE.**
  - (i) There are four alternatives for the answer to every question. For each question for which a wrong answer has been given by the candidate, **one-third (0.33)** of the marks assigned to that question will be deducted as penalty.
  - (ii) If a candidate gives more than one answer, it will be treated as a **wrong answer** even if one of the given answers happens to be correct and there will be same penalty as above to that question.
  - (iii) If a question is left blank, i.e., no answer is given by the candidate, there will be **no penalty** for that question.

---

 DO NOT OPEN THIS TEST BOOKLET UNTIL YOU ARE ASKED TO DO SO
 

---

1. The current gain of a bipolar transistor drops at high frequency because of
  - (a) Transistor capacitances
  - (b) High current effects in the base
  - (c) Parasitic inductive elements
  - (d) The early effect
  
2. The maximum depletion layer width in Silicon is
  - (a) 0.143  $\mu\text{m}$
  - (b) 0.857  $\mu\text{m}$
  - (c) 1  $\mu\text{m}$
  - (d) 1.143  $\mu\text{m}$
  
3. A bipolar transistor is operating in the active region with a collector current of 1 mA. The  $\beta$  of the transistor is 100 and the thermal voltage ( $V_T$ ) is 25 mV. The trans-conductance ( $g_m$ ) and the input resistance ( $r_\pi$ ) of the transistor in the common emitter configuration are, respectively
  - (a) 25 mA/V and 15.625 k $\Omega$
  - (b) 40 mA/V and 4.0 k $\Omega$
  - (c) 25 mA/V and 2.5 k $\Omega$
  - (d) 40 mA/V and 2.5 k $\Omega$
  
4. For a transformer, the load connected to the secondary has an impedance of 8  $\Omega$ . Its reflected impedance on primary is observed to be 648  $\Omega$ . The turns ratio of this transformer is
  - (a) 6 : 1
  - (b) 10 : 1
  - (c) 9 : 1
  - (d) 8 : 1
  
5. An amplifier with mid band gain  $|A| = 500$  has negative feedback  $|b| = \frac{1}{100}$ . If upper cut-off without feedback were at 60 kHz, then with feedback it would become
  - (a) 10 kHz
  - (b) 360 kHz
  - (c) 12 kHz
  - (d) 300 kHz
  
6. A tuned amplifier has a maximum output at 4 MHz with a quality factor 50. The bandwidth and half power frequencies are, respectively
  - (a) 80 kHz and 4.04 MHz; 3.96 MHz
  - (b) 80 kHz and 4.08 MHz; 3.92 MHz
  - (c) 40 kHz and 4.04 MHz; 3.96 MHz
  - (d) 40 kHz and 4.08 MHz; 3.92 MHz
  
7. A power amplifier with a gain of  $100 \angle 0^\circ$  has an output of 12 V at 1.5 kHz along with a second harmonic content of 25 percent. A negative feedback is to be provided to reduce the harmonic content of the output to 2.5 percent. What should be the gain of the feedback path and the level of signal input to the overall system, respectively ?
  - (a) 0.9 and 0.12 V
  - (b) 0.9 and 12 V
  - (c) 0.09 and 1.2 V
  - (d) 9 and 0.12 V
  
8. The right side of a state equation represents
  - (a) Next state of flip-flop
  - (b) Present state of flip-flop
  - (c) Present state condition that makes the next state equal to 1
  - (d) None of the above

9. A full wave rectifier with a centre-tapped transformer supplies dc current of 100 mA to a load resistance of 20  $\Omega$ . The secondary resistance of transformer is 1  $\Omega$ . Each diode has a forward resistance of 0.5  $\Omega$ . What are rms values of signal voltage across each half of the secondary as well as dc power supplied to the load ?
- (a) 2.39 V and 0.2 Watt  
 (b) 23.9 V and 2 Watts  
 (c) 0.239 V and 20 Watts  
 (d) 2.39 V and 2 Watts
10. An Op-Amp has the following open loop parameters  $Z_{in} = 300 \text{ k}\Omega$ ,  $Z_{out} = 100 \Omega$ ,  $A = 50,000$ . The low frequency system input and output impedances, when closed loop gain is set to 100, are
- (a) 0.6  $\Omega$  and 50 k $\Omega$   
 (b) 150 M $\Omega$  and 0.2  $\Omega$   
 (c) Same as in open loop  
 (d) None of the above
11. The differential gain of Op-Amp is 4000 and value of CMRR is 150. Its output voltage, when the two input voltages are 200  $\mu\text{V}$  and 160  $\mu\text{V}$  respectively, will be
- (a) 16 V  
 (b) 164.8 mV  
 (c) 64 mV  
 (d) 76 mV
12. An amplifier using an Op-Amp with a slew-rate  $SR = 1 \text{ V}/\mu \text{ sec}$  has a gain of 40 dB. If this amplifier has to faithfully amplify sinusoidal signals from 10 to 20 kHz, without introducing any slew-rate induced distortion, then the input signal level must *not* exceed
- (a) 795 mV  
 (b) 395 mV  
 (c) 79.5 mV  
 (d) 39.5 mV
13. Which oscillator is characterized by a split capacitor in its tank circuit ?
- (a) RC phase shift oscillator  
 (b) Colpitts oscillator  
 (c) Wien bridge oscillator  
 (d) None of the above
14. A 1  $\mu\text{s}$  pulse can be converted into a 1 ms pulse by using
- (a) A monostable multivibrator  
 (b) An astable multivibrator  
 (c) A bistable multivibrator  
 (d) A J-K flip-flop
15. The transistor switch as shown in figure has  $\beta = 120$ ,  $V_{CE(\text{Sat})} = 0.2 \text{ V}$ ,  $R_C = 1.2 \text{ k}\Omega$ , and  $V_{CC} = 5 \text{ V}$ .

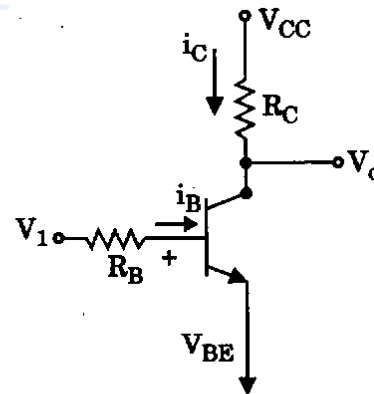

The output voltage when transistor switch is closed and the minimum base current needed to close the switch are, respectively

- (a) 0.2 V and 3.33  $\mu\text{A}$   
 (b) 2 V and 3.33  $\mu\text{A}$   
 (c) 0.2 V and 33.3  $\mu\text{A}$   
 (d) 2 V and 33.3  $\mu\text{A}$

16. A plant is controlled by a proportional controller. If a time delay element is introduced in the loop, its
- Phase margin remains the same
  - Phase margin increases
  - Phase margin decreases
  - Gain margin increases
17. When damping ratio is equal to zero, the damping frequency of a system is
- Equal to natural frequency
  - Zero
  - More than natural frequency
  - Less than natural frequency
18. The circuit shown in figure is

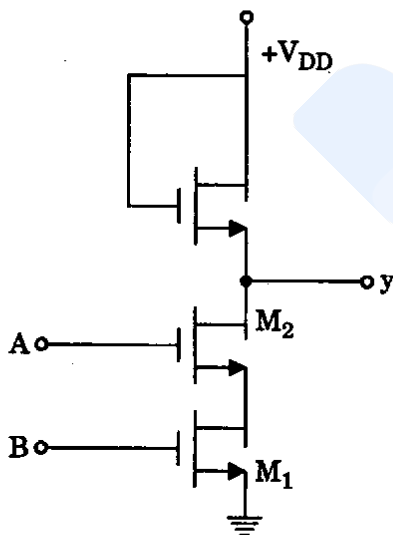

- OR gate
- NOR gate
- NAND gate
- AND gate

19. A binary-to-BCD encoder has four inputs  $D_0$ ,  $C_0$ ,  $B_0$  and  $A_0$  and five outputs D, C, B, A and VALID. The outputs D, C, B and A give the proper BCD value of the input and the VALID output is 1 if the input combination is a valid decimal code. If the input combination is an invalid decimal code, the VALID output becomes 0 and all of the D, C, B and A outputs show 0 values. If only NOT gates and 2-input OR and AND gates are available, the minimum number of gates required to implement the above circuit is
- 10
  - 9
  - 8
  - 7

20. In the J-K flip-flop we have  $J = \bar{Q}$  and  $K = 1$  as shown in the figure.

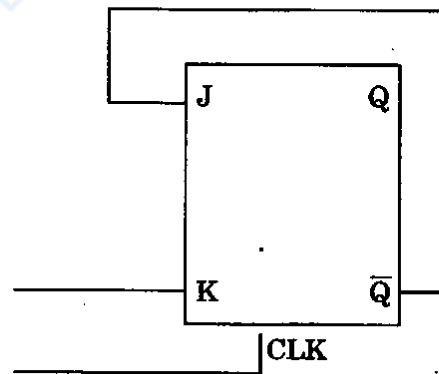

Assuming the flip-flop was initially cleared and then clocked for 6 pulses, the sequence at the Q output will be

- 010000
- 011001
- 010010
- 010101

21. The Boolean function 'f' implemented as shown in the figure using two input multiplexers is

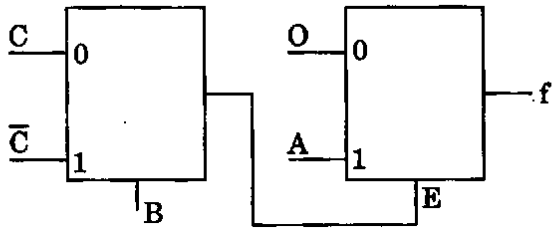

- (a)  $\overline{A}BC + A\overline{B}C$
- (b)  $ABC + \overline{A}\overline{B}C$
- (c)  $\overline{A}BC + ABC$
- (d)  $\overline{A}\overline{B}C + \overline{A}BC$

22. Consider the circuit shown in the figure. The expression for the next state  $Q(t + 1)$  is

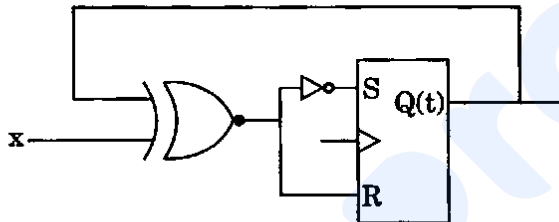

- (a)  $x Q(t)$
  - (b)  $x \oplus Q(t)$
  - (c)  $x \overline{Q}(t)$
  - (d)  $x \odot Q(t)$
23. The outputs  $Q$  and  $\overline{Q}$  of master slave S - R flip-flop are connected to its R and S inputs respectively. The output  $Q$  when clock pulses are applied will be
- (a) Permanently 0
  - (b) Permanently 1
  - (c) Fixed 0 or 1
  - (d) Complementing with every clock pulse

24. Consider the following statements :

1. A flip-flop is used to store 1 bit of information.
2. Race around condition occurs in a J-K flip-flop when both of its inputs are 1.
3. Master slave configuration is used in flip-flops to store 2 bits of information.
4. A transparent latch consists of D-type flip-flops.

Which of the above statements are correct ?

- (a) 1, 2 and 3
- (b) 1, 3 and 4
- (c) 1, 2 and 4
- (d) 2, 3 and 4

25. A circuit consists of two synchronously clocked J-K flip-flops connected as follows :

$J_0 = K_0 = \overline{Q}_1$ ,  $J_1 = Q_0$ ,  $K_1 = \overline{Q}_0$ . The circuit acts as a

- (a) Counter of mod 2
- (b) Counter of mod 3
- (c) Shift-right register
- (d) Shift-left register

26. A semiconductor RAM has a 12-bit address register and an 8-bit data register. The total number of bits in the memory is

- (a) 256 bits
- (b) 4,096 bits
- (c) 32,768 bits
- (d) 10,48,576 bits

27. When electromagnetic waves are propagated in a waveguide

- (a) They travel along the walls of the waveguide
- (b) They travel through the dielectric without touching the walls
- (c) They are reflected from the walls but do not travel along the walls
- (d) None of the above

28. A dual slope analog to digital converter uses N-bit counter. When the input signal  $V_a$  is being integrated, the counter is allowed to count up to the value
- Equal to  $2^N - 2$
  - Equal to  $2^N - 1$
  - Proportional to  $V_a$
  - Inversely proportional to  $V_a$
29. For a 5-bit ladder D/A converter which has digital input of 10101, the analog output value is (Assume  $0 = 0\text{ V}$  and  $1 = +10\text{ V}$ ,  $R_f = 3R$ )
- 3.32 V
  - 4.32 V
  - 6.56 V
  - 7.48 V
30. A 5-bit D/A converter has a current output. If an output current  $I_{\text{out}} = 10\text{ mA}$  is produced for a digital input of 10100, the value of  $I_{\text{out}}$  for a digital input of 11101 will be
- 12.5 mA
  - 13.5 mA
  - 15.5 mA
  - 14.5 mA
31. What is the total memory range and memory map, if for a 16-bit address bus;  $A_{15} = 1$ ,  $A_{14} = 0$  and  $A_{13} - A_{11}$  are connected to a 3-8 decoder input lines?  $A_{15}$  and  $A_{14}$  are connected to enable the decoder.
- 16 K, 8000H - 8FFFH
  - 2 K, 8000H - BFFFH
  - 16 K, 8000H - BFFFH
  - 2 K, 8000H - 8FFFH
32. A unity feedback system has  $G(s) = \frac{K(s+12)}{(s+14)(s+18)}$ . What is the value of K to yield 10% error in steady state?
- 672
  - 189
  - 100
  - 21
33. A unity feedback system has an open-loop transfer function  $G(s) = \frac{K}{s(s+10)}$ . If the damping ratio is 0.5, then what is the value of K?
- 150
  - 100
  - 50
  - 10
34. The loop transfer function of a system is  $\frac{K}{s(s+1)(s+5)}$ . The loop gain K is adjusted for inducing sustained oscillations. What is the value of K for this objective?
- 15
  - 25
  - 30
  - 45
35. The phenomenon known as 'Early effect' in a bipolar transistor refers to a reduction of the effective base-width caused by
- Electron-hole recombination at the base
  - The reverse-biasing of the base-collector junction
  - The forward-biasing of the emitter-base junction
  - The early removal of stored base charge during saturation to cut off switching
36. The number of roots of the equation  $2s^4 + s^3 + 3s^2 + 5s + 7 = 0$  which lie in the right half of s plane is
- 0
  - 1
  - 2
  - 3

37. Thermal runaway in a transistor biased in the active region is due to
1. heating of the transistor.
  2. change in  $\beta$  due to increase in temperature.
  3. change in reverse collector saturation current due to rise in temperature.
  4. base emitter voltage  $V_{BE}$  which decreases with rise in temperature.
- Which of the above statements is/are correct ?
- (a) 1 and 2
  - (b) 2 and 3
  - (c) 3 only
  - (d) 4 only
38. The majority carriers in an n-type semiconductor have an average drift velocity  $V_d$  in a direction perpendicular to a uniform magnetic field  $B$ . The electric field  $E$  induced due to Hall Effect acts in the direction
- (a)  $V_d \times B$
  - (b)  $B \times V_d$
  - (c) Along  $V_d$
  - (d) Opposite to  $V_d$
39. When the number of poles is equal to the number of zeros, how many branches of root locus tend towards infinity ?
- (a) 1
  - (b) 2
  - (c) 0
  - (d) Equal to number of zeros
40. The open-loop transfer function of a unity feedback control system is  $(s) = \frac{1}{(s+2)^2}$ . The closed-loop transfer function will have poles at
- (a)  $-2, -2$
  - (b)  $-2, -1$
  - (c)  $-2, \pm j$
  - (d)  $-2, 2$
41. Which one of the following statements is correct ?
- (a) Phase margin is always positive for stable feedback system.
  - (b) Phase margin is always negative for stable feedback system.
  - (c) Phase margin can be negative or positive for stable feedback system.
  - (d) None of the above
42. A Tachometer has a sensitivity of 5 V/1000 rpm. The Gain constant of the Tachometer is
- (a) 0.48 V/rad/sec
  - (b) 0.048 V/rad/sec
  - (c) 4.8 V/rad/sec
  - (d) 48 V/rad/sec
43. For a 3<sup>rd</sup> order system given below, what is the phase crossover frequency ?
- $$G(s)H(s) = \frac{K}{s^3 + 6s^2 + 11s + 6}$$
- (a)  $\sqrt{6}$
  - (b)  $\sqrt{11}$
  - (c)  $\pm \sqrt{11}$
  - (d)  $\pm \sqrt{6}$
44. Two compensators have transfer functions
- $$G_1(s) = \frac{5(s+10)}{(s+50)} \text{ and } G_2(s) = \frac{(s+50)}{5(s+10)}$$
- respectively.
- (a) Both are lag
  - (b) Both are lead
  - (c)  $G_1$  is lead and  $G_2$  is lag
  - (d)  $G_1$  is lag and  $G_2$  is lead

45. A proportional plus derivative controller
1. has high sensitivity.
  2. increases the stability of the system.
  3. improves the steady-state accuracy.
- Which of the above statements are correct ?
- (a) 1, 2 and 3
  - (b) 1 and 2 only
  - (c) 1 and 3 only
  - (d) 2 and 3 only
46. In industrial control system, which one of the following methods is most commonly used in designing a system for meeting performance specifications ?
- (a) The transfer function is first determined and then either a lead compensation or lag compensation is implemented
  - (b) The transfer function is first determined and PID controllers are implemented by mathematically determining PID constants
  - (c) PID controllers are implemented without the knowledge of the system parameters using Ziegler - Nichols method
  - (d) PID controllers are implemented using Ziegler - Nichols method after determining the system transfer function
47. Which one of the following is the transfer function of the PI-controller ?
- (a)  $G(s) = \frac{(k_1 s + k_2)}{k_3}$
  - (b)  $G(s) = \frac{(k_1 s + k_2 s + k_3)}{k_4 s}$
  - (c)  $G(s) = \frac{(k_1 s + k_2)}{k_3 s}$
  - (d)  $G(s) = \frac{k_1 s}{k_2 s}$
48. One of the main functions of the RF amplifiers in a super-heterodyne receiver is to
- (a) Provide improved tracking
  - (b) Permit better adjacent channel rejection
  - (c) Increase the tuning range of the receiver
  - (d) Improve the rejection of the image frequency
49. An FM signal has a carrier swing of 100 kHz when modulating signal has a frequency of 8 kHz. The modulation index is
- (a) 12.5
  - (b) 7.5
  - (c) 6.25
  - (d) 15
50. In a digital communication system employing Frequency Shift Keying (FSK), the 0 and 1 bit are represented by sine waves of 10 kHz and 25 kHz respectively. These waveforms will be orthogonal for a bit interval of
- (a) 250  $\mu$  sec
  - (b) 200  $\mu$  sec
  - (c) 50  $\mu$  sec
  - (d) 45  $\mu$  sec
51. If a 400-watt carrier is amplitude modulated to a depth of 75 percent, what is the total power in the modulated wave ?
- (a) 517.5 W
  - (b) 463.3 W
  - (c) 448.5 W
  - (d) 512.5 W
52. The signal  $m(t) = \text{sinc}(2 \times 10^4 t)$  is frequency modulated with  $K = 10^3$  Hz/V. What is the maximum instantaneous frequency of the modulated signal when carrier frequency is 1 MHz ?
- (a) 0.999 MHz
  - (b) 0.998 MHz
  - (c) 1.002 MHz
  - (d) 1.001 MHz

53. Amplitude modulation is used for broadcasting because
- It is more noise immune than other modulation systems
  - Compared with other systems it requires less transmitting power
  - Its use avoids receiver complexity
  - No other modulation system can provide the necessary BW for high fidelity
54. In flat-top sampling a hold circuit is sometimes required. This hold circuit can be designed as a sampler followed by
- A shunt capacitor
  - An envelope detector
  - Parallel RC circuit
  - A series resistance along with parallel RC circuit in shunt
55. As compared to A-law compander, the  $\mu$ -law compander produces
- More companding at low amplitudes
  - More companding at high amplitudes
  - Less companding for low amplitudes
  - Less companding for high amplitudes
56. A carrier is modulated by a digital bit stream having one of the possible phases of  $0^\circ$ ,  $90^\circ$ ,  $180^\circ$  and  $270^\circ$ . Then the modulation is termed as
- BPSK
  - QPSK
  - QAM
  - MSK
57. Consider the following :
- Pulse-position modulation.
  - Pulse-code modulation.
  - Pulse-width modulation.
- Which of the above communications are *not* digital ?
- 1 and 2 only
  - 2 and 3 only
  - 1 and 3 only
  - 1, 2 and 3
58. In a superheterodyne receiver, if the intermediate frequency is 450 kHz and the signal frequency is 1000 kHz, then the local oscillator frequency and image frequency respectively are
- 1450 kHz and 100 kHz
  - 550 kHz and 1900 kHz
  - 1450 kHz and 1900 kHz
  - 550 kHz and 1450 kHz
59. The cladding which surrounds the fibre core
- is used to protect the fibre
  - is used to reduce optical interference
  - helps to guide the light in the core
  - ensures that refractive index remains unaltered
60. In microwave relay communication, the repeater is usually an amplifier for the amplification of
- Carrier signal
  - Baseband signal
  - Amplitude modulated IF signal
  - Frequency modulated IF signal

61. In a geostationary satellite communication system, a message signal is transmitted from an earth station via an uplink to a satellite, amplified in a transponder on board the satellite and then transmitted via a downlink to another earth station. The most popular frequency band for satellite communication is
- 16 MHz for the uplink and 14 MHz for the downlink
  - 4 GHz for the uplink and 6 GHz for the downlink
  - 6 GHz for the uplink and 4 GHz for the downlink
  - 10 GHz for the downlink and 8 GHz for the uplink
62. As per WARC-1979 allocation, commercial communication satellites use bandwidth of
- 4 MHz
  - 40 MHz
  - 200 MHz
  - 500 MHz
63. Range resolution in RADAR is determined by
- The radiated power
  - The bandwidth of transmitted pulse
  - The antenna size
  - The centre frequency of RADAR
64. In satellite communication, Faraday rotation is caused by
- Plasma frequency
  - Earth's magnetic field
  - Non-Gaussian nature of uplink noise when received in the downlink channel
  - Ionospheric reflections that occur multiple times
65. What will be the total modulation index if a wave is amplitude modulated by three sine waves with modulation indices of 25%, 50% and 75%?
- $M_t = 1.5$
  - $M_t = 0.93$
  - $M_t = 1.22$
  - $M_t = 1$
66. Boosting of higher frequency at the transmitter is done by using
- De-emphasis
  - AGC circuit
  - Pre-emphasis
  - Armstrong method
67. The power contained in single sideband in amplitude modulation is
- $\frac{m^2 P_c}{2}$
  - $2 m^2 P_c$
  - $\frac{m^2 P_c}{4}$
  - $4 m^2 P_c$
68. TWT is characterized by
- Low noise figure, narrow bandwidth and average gain
  - Gain exceeding 40 dB, wide bandwidth and low noise figure
  - More noise and wide bandwidth
  - More noise, narrow bandwidth and high gain

69. In Gunn diodes, electrons are transferred from

- (a) High to low mobility energy bands
- (b) Low to high mobility energy bands
- (c) Valley to domain formation
- (d) Domain to valley formation

70. Polarization is characteristic of EM wave that gives the direction of

- (a) Electrical component of a wave with respect to ground
- (b) Magnetic component of EM wave with respect to ground
- (c) Both electrical and magnetic components with respect to ground
- (d) None of the above

71. A rectangular waveguide has the dimensions of 5.1 cm × 2.4 cm. For the dominant mode TE<sub>10</sub> the cut-off frequency is

- (a) 2.94 GHz
- (b) 5.88 GHz
- (c) 6.25 GHz
- (d) 68.99 GHz

72. The semiconductor random access memory of a computer has 65,536 words, each of 8-bits. It can perform two basic operations Read and Write. How many bits are there in the Address Register of this memory ?

- (a) 8
- (b) 12
- (c) 16
- (d) 24

73. 
$$S = \begin{bmatrix} 0 & 0 & S_{13} & S_{14} \\ 0 & 0 & S_{23} & S_{24} \\ S_{31} & S_{32} & 0 & 0 \\ S_{41} & S_{42} & 0 & 0 \end{bmatrix}$$

is the scattering matrix of

- (a) Magic Tee
- (b) Circulator
- (c) Hybrid ring
- (d) Three port network

74. Phase velocity  $v_p$  and group velocity  $v_g$  in a waveguide are related to the velocity of light  $c$  as

- (a)  $v_p v_g = c^2$
- (b)  $v_p + v_g = c$
- (c)  $\frac{v_p}{v_g} = \text{Constant}$
- (d)  $v_p + v_g = \text{Constant}$

75. Which one of the following is *not* a mode of operation of a Gunn diode ?

- (a) LSA oscillation mode
- (b) Stable amplification mode
- (c) Bias circuit oscillation mode
- (d) Non-linear mode

76. The only modes in microstrip lines are

- (a) TE modes
- (b) TM modes
- (c) TE and TEM modes
- (d) Quasi-transverse electric and magnetic modes

77. If the receiving antenna is polarized at  $90^\circ$  with respect to transmitting antenna, it will receive
- No signal
  - Minimum signal
  - Maximum signal
  - Same signal
78. Which of the following methods provides largest bandwidth ?
- Proximity coupling
  - Aperture coupling
  - Coaxial probe feed
  - Microstrip line feed
79. Which of the following antennas gives circular polarization ?
- Yagi-Uda
  - Parabolic
  - Helical
  - Dipole
- 1, 2, 3 and 4
  - 1, 2 and 3 only
  - 3 only
  - 4 only
80. If the diameter of a  $\frac{\lambda}{2}$  dipole antenna is increased from  $\frac{\lambda}{100}$  to  $\frac{\lambda}{50}$ , then its
- Bandwidth increases
  - Bandwidth decreases
  - Gain increases
  - Gain decreases
81. The efficiency of an antenna having a resistance of  $30 \Omega$  and radiation resistance of  $60 \Omega$  is
- 33.3%
  - 50%
  - 66.6%
  - 75%
82. An antenna behaves as a Resonant Circuit if
- Its length is integral multiple of  $\frac{n\lambda}{2}$
  - Its height is integral multiple of  $\frac{n\lambda}{2}$
  - Its length is even multiple of  $\frac{n\lambda}{2}$
  - Its length is odd multiple of  $\frac{n\lambda}{2}$
83. Magic Tee is called as
- E-H plane Tee
  - Hybrid Tee
  - Mixer circuit
  - All of the above
84. A transmission line has characteristic impedance of  $500 \Omega$ . It has been terminated in a  $200 \Omega$  load. If the load is dissipating a continuous power of 100 W, its reflection coefficient is
- $\frac{6}{7}$
  - $\frac{4}{7}$
  - $\frac{3}{7}$
  - $\frac{2}{7}$

85. Detection of microwaves is carried out by employing
- Vacuum tube diode
  - Semiconductor diode
  - Schottky Barrier diode
  - Field-Effect Transistor
86. The frequency range of very high frequency (VHF) is
- 300 MHz – 3000 MHz
  - 30 MHz – 300 MHz
  - 3 MHz – 30 MHz
  - 30 THz – 3000 Hz
87. On a microstrip line the wavelength measured is 12 mm for a 10 GHz signal. The dielectric constant of the equivalent homogeneous line is
- 3.5
  - 6.25
  - 5.5
  - 7.0
88. Microwave link repeaters are typically 50 km apart in TV transmission, because
- of atmospheric attenuation
  - of output power tube limitation
  - microwave transmission is through surface wave which attenuates faster
  - of Earth's curvature
89. The ratio  $\frac{\sigma}{\omega \epsilon}$  is called
- Intrinsic ratio.
  - Loss tangent.
  - Conduction ratio.
  - Dissipation factor.
- Which of the above statements is/are correct ?
- 1 only
  - 2 only
  - 2 and 4
  - 2 and 3
90. Baretters and Bolometers are used for measurement of
- VSWR
  - Transmission losses
  - Microwave power
  - None of the above
91. The disc antenna is
- A useful direction finding antenna
  - Used as a radar receiving antenna
  - Circularly polarized like other circular antennas
  - Useful as VHF receiving antenna
92. A satellite link uses different frequencies for receiving and transmitting in order to
- Avoid interference from terrestrial microwave link
  - Minimize free space losses
  - Maximize antenna gain
  - Avoid interference between its powerful transmitted signal and weak incoming signal
93. The number of one's present in the binary representation of  $15 \times 256 + 5 \times 16 + 3$  are
- 8
  - 9
  - 10
  - 11
94. The creation of file variable will automatically create a special variable associated with it, called as
- Buffer variable
  - Text variable
  - Allocated variable
  - Floating variable

95. Wrapping of data functions together in a class is known as
- Overloading
  - Data Abstraction
  - Polymorphism
  - Encapsulation
96. Given  $(135)_{\text{base } x} + (144)_{\text{base } x} = (323)_{\text{base } x}$ . What is the value of base  $x$ ?
- 5
  - 3
  - 12
  - 6
97. Expression  $C = i++$  causes
- value of  $i$  to be assigned to  $C$ , and then  $i$  to be incremented by 1
  - $i$  to be incremented by 1, and then value of  $i$  to be assigned to  $C$
  - value of  $i$  to be assigned to  $C$
  - $i$  to be incremented by 1
98. The addressing mode that permits relocation, without any change whatsoever in the code, is
- Indirect addressing
  - Base register addressing
  - Indexed addressing
  - PC relative addressing
99. Which of the following algorithm design techniques is used in the quick sort algorithm?
- Dynamic programming
  - Backtracking
  - Divide and conquer
  - Greedy method
100. An algorithm is made up of 2 modules  $M_1$  and  $M_2$ . If order of  $M_1$  is  $f(n)$  and that of  $M_2$  is  $g(n)$ , then the order of the algorithm is
- $f(n) \times g(n)$
  - $f(n) + g(n)$
  - $\min(f(n), g(n))$
  - $\max(f(n), g(n))$
101. Which of the following sorting methods will be the best, if the number of swappings done, is the only measure of efficiency?
- Bubble sort
  - Quick sort
  - Insertion sort
  - Selection sort
102. In a circularly linked list organization, insertion of a record involves the modification of
- No pointer
  - 1 pointer
  - 2 pointers
  - 3 pointers
103. The average successful search time for sequential search on 'n' items is
- $\frac{(n+1)}{2}$
  - $\frac{n}{2}$
  - $\frac{(n-1)}{2}$
  - $\log(n) + 1$
104. The speed mismatch between Processor and Memory in a computer is alleviated by using a small fast memory as an intermediate buffer between Memory and Processor. This buffer memory is known as
- Volatile ROM
  - Non-Volatile ROM
  - Cache Memory
  - EPROM

- 105.** What is maximum number of nodes in a binary tree that has  $N$  levels, if the root level is zero ?
- $2^{2N}$
  - $2^{N+1} - 1$
  - $2^N - 1$
  - $2^N - 2N$
- 106.** To arrange a binary tree in ascending order, we need
- Post order traversal only
  - In order traversal only
  - Pre order traversal only
  - Post order traversal and Pre order traversal
- 107.** The method used for resolving data dependency conflict by the compiler itself is
- Delayed load
  - Operand forwarding
  - Prefetch target instruction
  - Loop buffer
- 108.** The micro programs provided by a manufacturer to be used on his micro programmed computer are generally called
- Software
  - Netware
  - Firmware
  - Hardware
- 109.** Locality of reference concept will fall in which of the following cases ?
- Where there are
- Many conditional jumps
  - Many unconditional jumps
  - Many operands
  - None of the above
- 110.** Consider the following statements regarding RESET instruction of 8085 microprocessor :
- PC contents become 0000H.
  - All interrupts are enabled.
  - RESET OUT pin is at logic 0.
- Which of the above statements is/are correct ?
- 1 only
  - 2 only
  - 1 and 2
  - 2 and 3
- 111.** In a microprocessor, the register which holds address of the next instruction to be fetched is
- Accumulator
  - Program counter
  - Stack pointer
  - Instruction register
- 112.** The following sequence of instructions is executed by an 8085 microprocessor :
- ```

1000 LXI SP, 27FF
1003 CALL 1006
1006 POP H
  
```
- The contents of the stack pointer (SP) and the HL register pair on completion of execution of these instructions are
- SP = 27 FF, HL = 1003
  - SP = 27 FD, HL = 1003
  - SP = 27 FF, HL = 1006
  - SP = 27 FD, HL = 1006
- 113.** The semiconductor RAM of a digital computer has a word length of 16-bits and a capacity of 65,536 words. It has a cycle time of 80 ns. If the CPU is much faster than the memory, the time required to fill 1,024 bytes of this memory with all 0's will be
- 40.96  $\mu$ s
  - 81.92  $\mu$ s
  - 5.24 ms
  - 10.48 ms

**Directions :** Each of the next seven (07) items consists of two statements, one labelled as the 'Statement (I)' and the other as 'Statement (II)'. Examine these two statements carefully and select the answers to these items using the codes given below :

**Codes :**

- (a) Both Statement (I) and Statement (II) are individually true and Statement (II) is the correct explanation of Statement (I).
- (b) Both Statement (I) and Statement (II) are individually true but Statement (II) is *not* the correct explanation of Statement (I).
- (c) Statement (I) is true but Statement (II) is false.
- (d) Statement (I) is false but Statement (II) is true.

**114. Statement (I) :**

A NAND gate represents a universal logic family.

**Statement (II) :**

Only two NAND gates are sufficient to accomplish any of the basic gates.

**115. Statement (I) :**

Digital ramp converter is the slowest ADC.

**Statement (II) :**

It requires  $N^2$  clock pulses for conversion.

**116. Statement (I) :**

The  $\beta$  of a bipolar transistor is reduced, if the base width is increased.

**Statement (II) :**

The  $\beta$  of a bipolar transistor increases, if the doping concentration in the base is increased.

**117. Statement (I) :**

Space wave is used for propagation of FM broadcast system.

**Statement (II) :**

Several independent interference-free transmitters can be operated on the same frequency because of line-of-sight propagation.

**118. Statement (I) :**

In  $TE_{mn}$  modes Z component of magnetic field is non-zero.

**Statement (II) :**

In  $TE_{mn}$  modes Z component of electric field is non-zero.

**119. Statement (I) :**

On-chip Cache memory is used for temporary storage of commonly used code/data copied from the main memory.

**Statement (II) :**

Provision of Cache memory eliminates the need for the processor to go off the chip to access the main memory thus improving the processor performance.

**120. Statement (I) :**

In the main memory of a computer, RAM is used as a short-term memory.

**Statement (II) :**

RAM is a volatile memory.

**SPACE FOR ROUGH WORK**

prepp  
Your Personal Exam Guide

**SPACE FOR ROUGH WORK**

prepp  
Your Personal Exam Guide

**SPACE FOR ROUGH WORK**

prepp  
Your Personal Exam Guide

**SPACE FOR ROUGH WORK**

prepp  
Your Personal Exam Guide