

SECTION—A

1. (a) Find the support reaction at the fixed end A of the loaded beam :

12

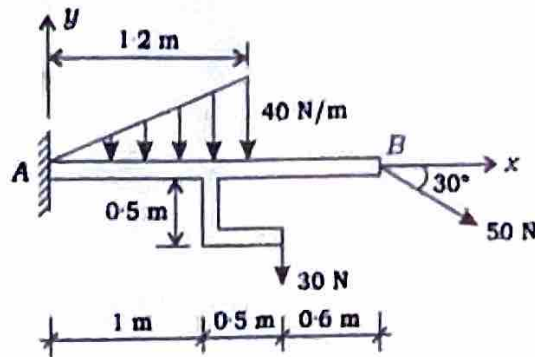

(b) The straight bar AD of uniform cross-section is attached to the rigid end supports. Find the force acting on any cross-section in the regions AB, BC and CD :

12

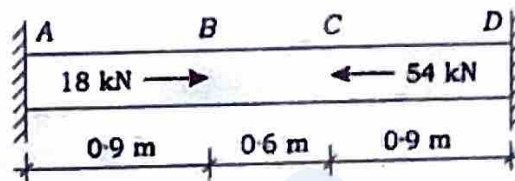

(c) (i) Determine the degrees of freedom of the following planar linkages/kinematic chains :

(1)

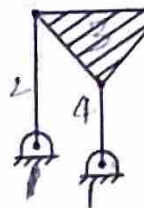

$3(3-1) - 2(3) = 0$
 $3(6-1) - 2(7) = 1$

(3)

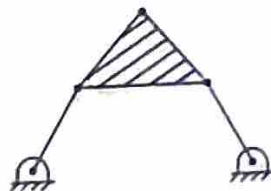

(2)

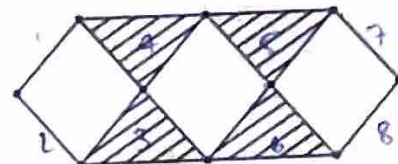

$3(8) - 2(10) = 4$

(4)

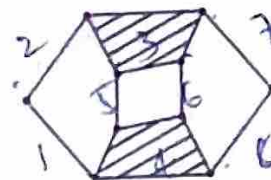

(5)

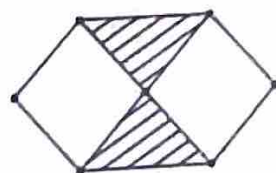

(6)

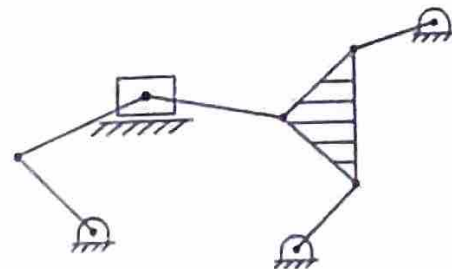

(ii) Determine and show the structurally distinct (unique) inversions of the following 8-link kinematic chain :

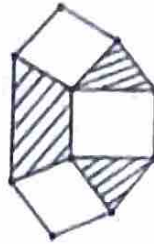

6+6=12

(d) The turbine rotor of a ship has a mass of 2.5 tonnes and rotates at 1750 r.p.m. clockwise when viewed from the aft. The radius of gyration of the rotor is 320 mm. Determine the gyroscopic couple and its effect when (i) the ship turns right at a radius of 250 m with a speed of 30 km/hr, (ii) the ship pitches with the bow rising at an angular velocity of 0.7 rad/s and (iii) the ship rolls at an angular velocity of 0.2 rad/s.

12

(e) What is the relationship between tensile and shear yield stresses as per (i) von Mises' criterion and (ii) Tresca's criterion?

The above relationships are to be derived by considering yielding under uniaxial tensile loading and under pure torsion.

12

2. (a) A smooth sphere of mass 1.5 kg is released from rest in the position when the flexible string attached to it is horizontal. It hits centrally a stationary block of mass 1.8 kg kept on a surface, with the coefficient of friction between the block and the surface being 0.3. If the coefficient of restitution is 0.8, how far would the block move after impact?

20

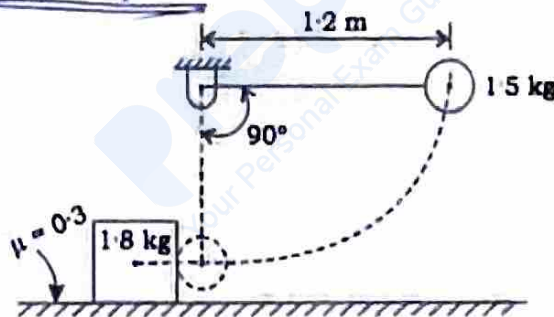

(b) (i) Derive the formulation for path of contact of two gears A and B in contact as shown in the figure :

10

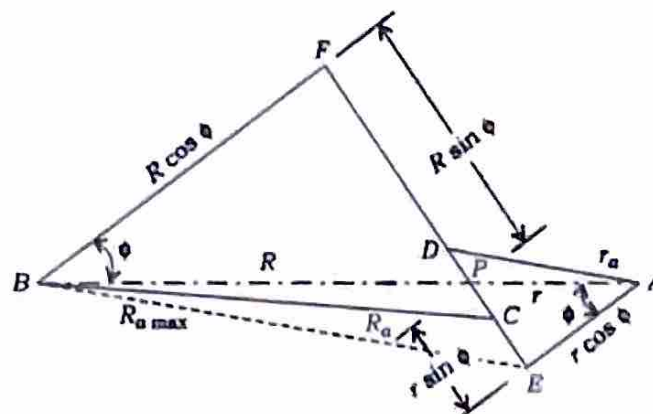

(ii) Each of two gears in a mesh has 48 teeth and a module of 8 mm. The teeth are of 20° involute profile. The arc of contact is 2.25 times the circular pitch. Determine the addendum and contact ratio. 10

(c) A cam having a lift of 1.2 cm operates the suction valve of a four-stroke petrol engine. The least radius of the cam is 2 cm and nose radius is 0.3 cm. The crank angle of the engine when suction valve opens is 4° after t.d.c. and it is 50° after b.d.c. when the suction valve closes. The camshaft has a speed of 960 r.p.m. The cam is of circular type with circular nose and flanks. It is integral with camshaft and operates a flat-faced follower. Calculate (i) the maximum velocity of the valve, (ii) the maximum acceleration and retardation of the valve and (iii) the minimum force to be exerted by the spring to overcome inertia of the valve parts which weigh 250 g. 20

3. (a) Show the loading on the beam corresponding to the bending moment diagram shown in the figure. The beam is simply supported at A and B : 20

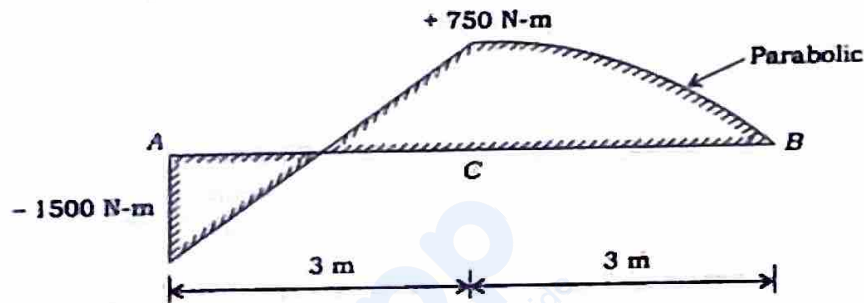

(b) A shaft 1.7 cm diameter and 1.2 m long is held in long bearings. The weight of a disc at the centre of the shaft is 20 kg. The eccentricity of the centre of gravity of the disc from centre of rotor is 0.03 cm. The Young's modulus of material of the shaft is $2 \times 10^6 \text{ kg/cm}^2$. The permissible stress in the shaft material is 750 kg/cm^2 . Calculate (i) the critical speed of the shaft and (ii) the range of speed over which it is unsafe to run the shaft. Neglect weight of the shaft. 20

(c) (i) A bolted joint is used to connect two components. The combined stiffness of the two components is twice the stiffness of the bolt. The initial tightening of the nut results in a preload of 10 kN in the bolt. The external force of 7.5 kN creates further tension in the bolt. The bolt is made of plain carbon steel 30C8, having tensile yield strength of 400 N/mm^2 . There are coarse threads on the bolt. Calculate the tensile stress area of the bolt. The factor of safety specified is 3. 10

(ii) An oil ring of a shaft transmitting power is shown in the figure. There is no hydrodynamic action over 5 mm width of the oil ring. The total radial load on the journal is 21 kN and the journal rotates at 1440 r.p.m.

$$\frac{c}{r} = 0.8 \times 10^{-3}; \quad \frac{h_0}{c} = 0.2$$

where c = radial clearance, r = radius and h_0 = minimum oil thickness.

For the instant case, Sommerfeld number $(S) = 0.0446$.

For this case, calculate the viscosity of lubricant :

10

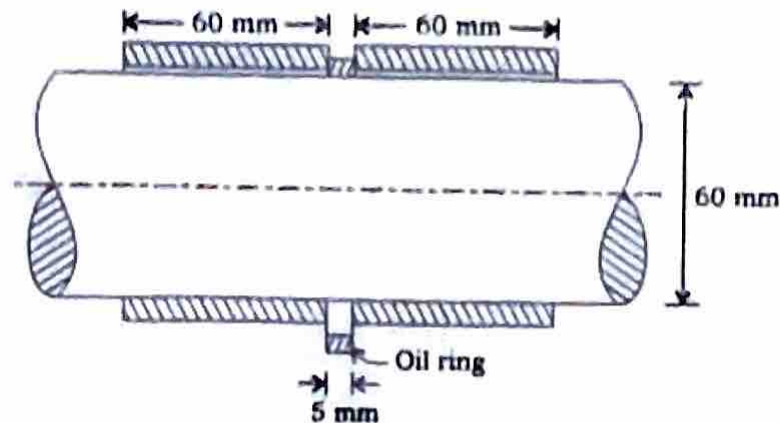

4. (a) A thick cylinder of 225 mm internal diameter has to be designed for a safe internal pressure of 50 MPa. Calculate the thickness of the cylinder wall using maximum shear stress theory. The axial stress may be neglected in the calculation. The yield stress of the cylinder material is 260 MPa and the factor of safety is 2.

20

- (b) A riveting machine is driven by a motor of 4 kW. The actual time to complete one riveting operation is 1.5 seconds and it absorbs 12 kN-m of energy. The moving parts including the flywheel are equivalent to 220 kg at 0.5 m radius. Determine the speed of the flywheel immediately after riveting, if it is 380 r.p.m. before riveting. Also determine the number of rivets closed per minute.

20

- (c) Refer to the following figure of the drum brake.

Prove that the braking torque (T_f) can be expressed as

$$T_f = P_2 R (e^{\mu\alpha} - 1) \quad \text{and} \quad T_f = b R^2 p_{\max} (1 - e^{-\mu\alpha})$$

where R = drum radius, b = width, p = pressure at any point in the arc of contact and P = tensile force in the band at the same point :

20

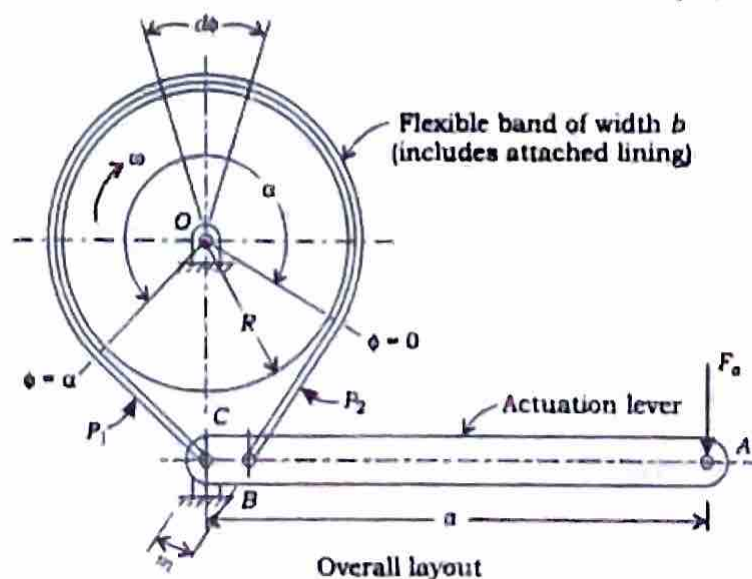

SECTION—B

5. (a) Zirconium has an HCP crystal structure and a density of 6.51 g/cm^3 . The atomic weight of zirconium is 91.22 g/mol . Answer the following :
- (i) What is the volume of its unit cell in cubic metres? 12
- (ii) If the c/a ratio is 1.593 , compute the values of c and a . 12
- (b) Give at least four comparisons between honing and lapping. Also list at least three functions performed by electrolyte in electrochemical machining (ECM) process. 12
- (c) List five causes of service failure giving example of at least one mechanical component in which it occurs. Also list at least five causes of vibration in mechanical system. 12

An automobile has four tyres. The constant failure rates of tyres 1, 2, 3 and 4 are $0.00001 \text{ failure/hour}$, $0.00002 \text{ failure/hour}$, $0.00003 \text{ failure/hour}$ and $0.00003 \text{ failure/hour}$ respectively. The automobile cannot be driven when any one of the tyres punctures. Find the mean time to failure of the automobile with respect to tyres and reliability for operating the automobile for 500 hours without failure of tyres. 12

- (d) You are a consultant for operations of a firm that deals with just one item that costs ₹ 45. The firm buys the item wholesale from a supplier and sells retail. You have compiled the following details for the item :

Parameters	Values
Annual demand	4380
Workdays/year	365
Opportunity cost of investment in inventory	12.5%
Fixed cost of order generation per order	₹ 22
Cost of inspecting items received	₹ 3
Cost due to breakage or spoilage	9.5%
Warehouse rental	6.5%
Insurance costs	1.5%

The following two options are available to you :

Option 1 : The supplier can supply all items at once

Option 2 : The supplier can supply 15 items per day

Which of the options would you recommend to the firm and why? 12

(a) Compare between hydraulic and electrical actuators' characteristics in the following points in brief :

- (i) Stiffness of the actuators
- (ii) Need of reduction gear
- (iii) Need of braking device
- (iv) Working in low and high temperature
- (v) Working of the actuators
- (vi) Maintenance need of the actuators

6. (a) (i) Three jobs are to be processed in a job shop consisting of three machines. Each job requires three operations and they are to be carried out in 1 → 2 → 3 order. The following table indicates the machines required as well as processing time (in hours) required for each operation. Initially, all jobs and machines are available. Compute the makespan by drawing Gantt chart indicating every operation of each job using shortest processing time dispatching rule and break ties with least work remaining rule :

10

	Machine required for operation			Processing time of operation		
	1	2	3	1	2	3
Job 1	M1	M2	M3	4	2	3
Job 2	M1	M3	M2	2	4	4
Job 3	M3	M2	M1	3	5	3

(ii) Explain the physics of arc initiation in arc welding. Why is arc initiation difficult in plasma arc welding? Why is plasma arc welding called as plasma arc welding despite the fact that plasma is present in all other arc welding processes?

10

(b) (i) Briefly describe the techniques that may be used for galvanic protection. Also explain why cold-worked metals are more susceptible to corrosion than non-cold-worked metals.

10

(ii) Write the possible oxidation and reduction half-reactions that occur when magnesium is immersed in each of the following solutions :

- (1) HCl
- (2) HCl solution containing dissolved oxygen
- (3) HCl solution containing dissolved oxygen and in addition Fe^{2+} ions

In which of the above solutions would you expect the magnesium to oxidize rapidly and why?

10

- (c) (i) The forward kinematic model of a planar 2 DOF (RR) manipulator with link lengths $a_1 = a_2 = 10$ units, is given by the matrix

$${}^0T_2 = \begin{bmatrix} 0 & -1 & 0 & 10/\sqrt{2} \\ 1 & 0 & 0 & 10+10/\sqrt{2} \\ 0 & 0 & 1 & 0 \\ 0 & 0 & 0 & 1 \end{bmatrix}$$

Draw the last frame (2), with respect to (0) frame, by locating its position and its orientation. The initial frame, frame (0) is given as

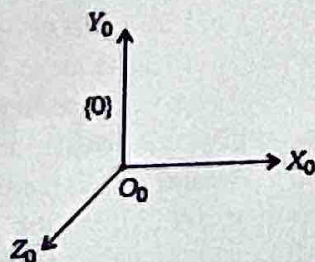

10

- (ii) For the given frames of SCARA manipulator, generate the DH parameters table :

10

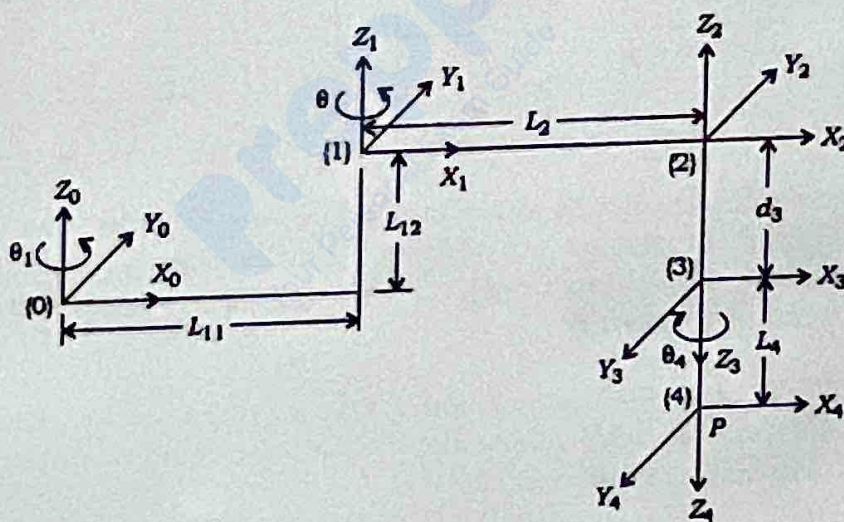

7. (a) (i) How does permeability of molding sand vary with the moisture content? Explain with the help of neat sketches. Also explain the role of adding organic additives in the molding sand.

10

- (ii) A dimension 57.975 mm is required to be set with the help of slip gauge blocks as accurately as possible. Two slip gauge block sets M45 (Grade 0)

Also draw the last frame (3), if θ_1 , d_2 and d_3 are given respectively as 0° , 10 units and 10 units, with reference to the given initial frame :

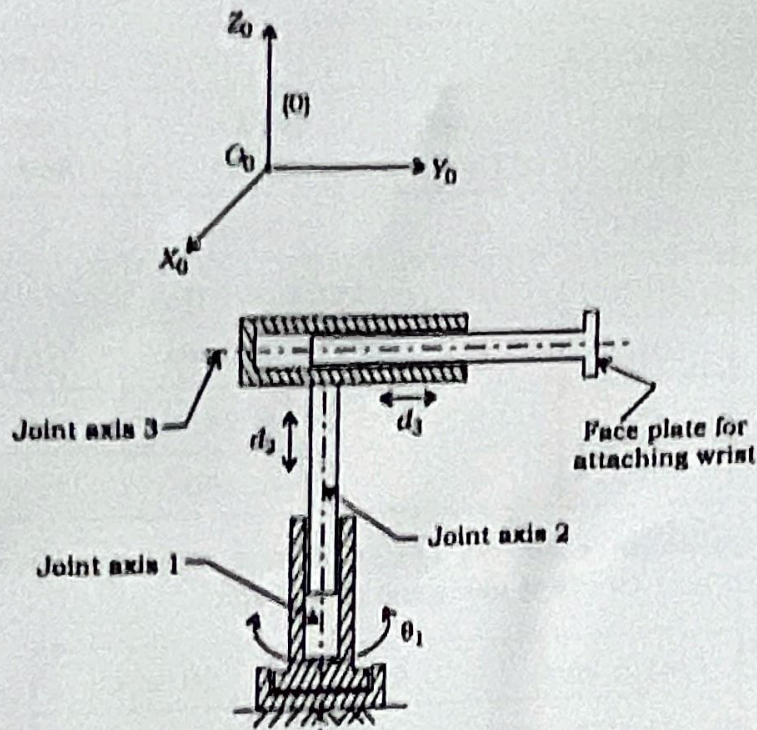

The homogeneous transformation matrix ${}^{i-1}T_i$ is given as

$${}^{i-1}T_i = \begin{bmatrix} c\theta_i & -s\theta_i c\alpha_i & s\theta_i s\alpha_i & a_i c\theta_i \\ s\theta_i & c\theta_i c\alpha_i & -c\theta_i s\alpha_i & a_i s\theta_i \\ 0 & s\alpha_i & c\alpha_i & d_i \\ 0 & 0 & 0 & 1 \end{bmatrix}$$

20

8. (a) A 12.7 mm diameter steel wire is drawn to obtain 35.5% reduction in area by drawing through a conical die of 6° semi-cone angle. The coefficient of friction between the wire material and die material at conical portion of die is 0.1 and there is no back pull. The tensile yield strength of the original specimen is 207 MPa and is 414 MPa at a strain of 0.5. Assuming linear stress relationship for the wire material and efficiency of electrical motor as 98%, find the drawing power and maximum possible reduction.

20

- (b) (i) The transformation of frame (i-1) to frame (i) consists of four basic transformations as following :

- (1) A rotation about Z_{i-1} axis by an angle θ_i
- (2) A translation along Z_{i-1} axis by distance d_i
- (3) A translation along X_i axis by distance a_i
- (4) A rotation about X_i axis by an angle α_i

Generate the individual transformation matrices and also the composite transformation matrix ${}^{i-1}T_i$, due to the above successive transformations.

If all the above parameters (DH) are zero, what will be the composite transformation matrix? 10

(ii) Explain the following sensor characteristics in brief : 10

- (1) Range
- (2) Resolution
- (3) Reliability
- (4) Repeatability
- (5) Sensitivity

(c) (i) Generate a forward kinematic model of the given two degrees of freedom (RP) planar manipulator.

(ii) Determine the joint variables (θ_1, d_2) for the above manipulator using inverse kinematic model, if the position and orientation of the end-effector are given by the following matrix :

$$T_E = \begin{bmatrix} 0.707 & 0 & 0.707 & 70.71 \\ 0.707 & 0 & -0.707 & -70.71 \\ 0 & 1 & 0 & 0 \\ 0 & 0 & 0 & 1 \end{bmatrix}$$

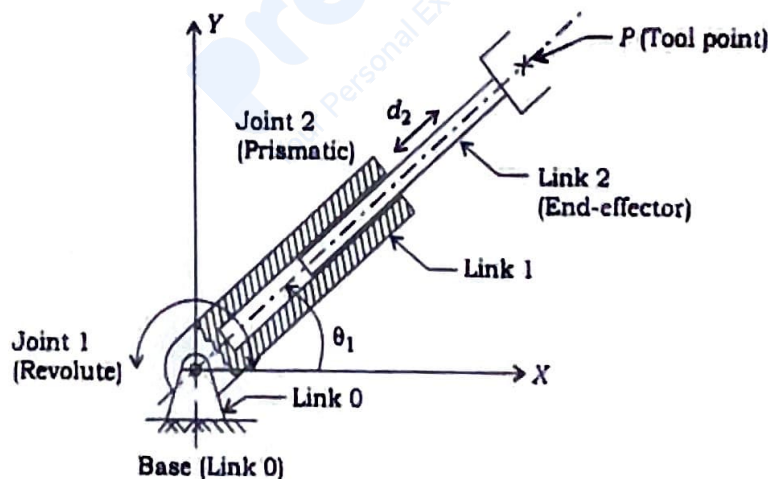

Given that

$${}^{i-1}T_i = \begin{bmatrix} c\theta_i & -s\theta_i\alpha_i & s\theta_i\alpha_i & a_i c\theta_i \\ s\theta_i & c\theta_i\alpha_i & -c\theta_i\alpha_i & a_i s\theta_i \\ 0 & \alpha_i & \alpha_i & d_i \\ 0 & 0 & 0 & 1 \end{bmatrix}$$

20