

Prepp

Your Personal Exams Guide



NDA



CDS



SSC CGL



CBSE UGC NET



IAS



SSC CHSL



CTET



MPSC



AFCAT



CSIR UDC NET



IBPS PO



UP POLICE



SSC MTS



SBI PO



BPSC



UP TET



IBPS RRB



IBPS CLERK



IES



UPSC CAPF



SSC Stenogr..



RRB NTPC



SSC GD



RBI GRADE B



RBI Assistant



DSSSB

RRB ALP 2019 (CBT 2) (Physics and Maths) Previous Year Papers (22 Jan 2019) Shift 2

Total Time: 1 Hour

Total Marks: 75

Instructions

Sl No.	Section Name	No. of Question	Maximum Marks	Negative Marks	Positive Marks
1	Part B	75	75	0.33	1

- 1.) A total of 60 minutes is allotted for the examination.
- 2.) The server will set your clock for you. In the top right corner of your screen, a countdown timer will display the remaining time for you to complete the exam. Once the timer reaches zero, the examination will end automatically. The paper need not be submitted when your timer reaches zero.
- 3.) There will, however, be sectional timing for this exam. You will have to complete each section within the specified time limit. Before moving on to the next section, you must complete the current one within the time limits.

Your Personal Exams Guide

Part B

1. The following lines with the equations (+1, -0.33)

$$x + 2y = 12,$$

$$4x + 8y = 48$$

- a. are perpendicular to each other
 - b. are coincident with each other
 - c. are parallel
 - d. pass through the origin
-
2. What is the radius of a circle in cm where the central angle of 30° intercepts an arc of length 2 cm? (take $\pi = 22 / 7$) (+1, -0.33)
- a. 3.98
 - b. 3.72
 - c. 3.82
 - d. 3.56
-

3. A concave mirror produces a three times magnified (enlarged) real image of an object placed at 10 cm in front of it. Which option describes the image currently? (+1, -0.33)
- a. An inverted image is formed at a distance of 20 cm in front of the given concave mirror.
 - b. An erect image is formed at a distance of 30 cm in front of the given

concave mirror

- c. An inverted image is formed at a distance of 30 cm in front of the given concave mirror
- d. An erect image is formed at a distance of 20 cm in front of the given concave mirror

4. In a right-angled triangle, right-angled at A , what is the value of $\sec B$, if BC is 5.2 cm and AB is 3 cm. (+1, -0.33)

- a. 1.6
- b. 1.07
- c. 1.5
- d. 1.7

5. A 165 cm tall man standing 500 cm away from the wall looks at a hooks on the wall with an angle of elevation of 45° what is the height at which the hooks is in the wall? (+1, -0.33)

- a. 600 cm
- b. 750 cm
- c. 700 cm
- d. 665 cm

6. Find the mean of the following numbers: (+1, -0.33)

20, 18, 16, 25, 19, 22, 18, 16, 23, 14

- a. 19.01
- b. 18.6
- c. 19.1
- d. 18.5

7. If g on the surface of the earth is $10m/s^2$, its value at a height of 6400 km is (+1, -0.33)
(Radius of the earth = 6400 km)

- a. $5 ms^{-2}$
- b. $20 ms^{-2}$
- c. $2.5 ms^{-2}$
- d. $10 ms^{-2}$

8. The radii of the internal and external surfaces of a hollow spherical shell are (+1, -0.33)
4 cm and 6 cm respectively. If is melted and recast into a solid cylinder of
height $4/3$ cm, find the diameter of the cylinder.

- a. $2\sqrt{38}$ cm
- b. $4\sqrt{38}$ cm
- c. $4\sqrt{19}$ cm
- d. $3\sqrt{38}$ cm

9. By applying the brakes without causing a skid, the driver of a car is able to (+1, -0.33)
stop within a distance of 5m, if it is going at 36 kmph. If the car were going at
72 kmph, using the same brakes, he can stop the car over a distance of:

- a. 10 m
- b. 20 m
- c. 40 m
- d. 2.5 m

10. What would be the 178th term in the following series? (+1, -0.33)

2, 5, 8, 11, 14,

- a. 536
- b. 533
- c. 539
- d. 531

11. For a pair of similar triangles shown in the figure, the angles made at B and R are same in both the triangles BAC and RAQ. If the ratio of the areas of the two triangles is 2 : 1, and if the area of BAC is 100 cm² then what is the area of RAQ in sq.cm.?

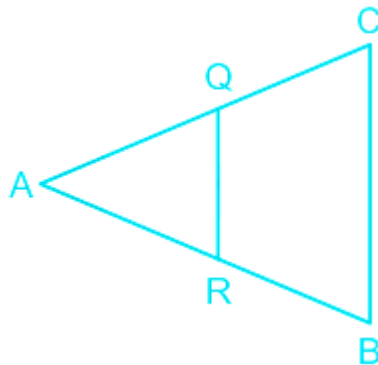

- a. 50

- b. 4
 - c. 5
 - d. 10
-

12. If $x = 2$ is one of the zeros of the polynomial $x^3 - 6x^2 + 11x - 6$, which are the other two zeros? (+1, -0.33)

- a. 1, 3
 - b. 1, -3
 - c. -1, -3
 - d. -1, 3
-

13. When white light enters a prism, it gets splitted into its constituent colours. This is due to: (+1, -0.33)

- a. diffraction of light
 - b. interference of light
 - c. high density of prism material
 - d. because speed of light is different for different wavelengths
-

14. A lorry and a car moving with the same kinetic energy are brought to rest by applying the same retarding force. Then: (+1, -0.33)

- a. lorry will come to rest in a shorter distance
- b. car will come to rest in a shorter distance

- c. in order to know which one will come to rest in a shorter distance, one needs to know the masses of the lorry and the car
 - d. both come to rest in same distance
-

15. When one joule of energy is consumed in one second, then the power used is said to be? **(+1, -0.33)**

- a. one watt
 - b. one coulomb
 - c. one volt
 - d. one ampere
-

16. The ratio of potential difference across the terminals of a conductor to the current flowing through it is the: **(+1, -0.33)**

- a. resistance
 - b. resistivity
 - c. conductivity
 - d. conductance
-

17. The shadow of a candle fell on the table and made a right-angled triangle with an angle of elevation of 60° from the surface of the table to the upper tip of the flame of the candle. If the length of the candle is 21 cm, how long is the tip of the shadow on the table away from the base of the candle? **(+1, -0.33)**

- a. $2\sqrt{3}$ cm

- b. $4\sqrt{3}$ cm
- c. $\sqrt{3} / 2$ cm
- d. $7\sqrt{3}$ cm

18. Find the roots of the following equation

(+1, -0.33)

$$x^2 + 12x - 36 = 0$$

- a. $6(1 + \sqrt{2}), -6(\sqrt{2} - 1)$
- b. $-6(1 + \sqrt{2}), 6(\sqrt{2} - 1)$
- c. $9(1 + \sqrt{2}), -9(\sqrt{2} - 1)$
- d. $6(1 + \sqrt{2}), 6(\sqrt{2} - 1)$

19. A dice is thrown once. Find the probability of getting an even prime number?

(+1, -0.33)

- a. $1/2$
- b. $1/3$
- c. $1/6$
- d. $2/5$

20. A thin prism P_1 of angle 4° and refractive index 1.54 is combined with another thin prism P_2 of refractive index 1.72 to produce dispersion without deviation. The angle of P_2 is

(+1, -0.33)

- a. 3°

- b. 2.6°
- c. 4°
- d. 5.33°

21. Simplify the given expression-

(+1, -0.33)

$$21 \times (23 - 12) - ((-1 \times 10) + 21)$$

- a. 210
- b. 190
- c. 220
- d. 0

22. What is the real part of the number $5i$?

(+1, -0.33)

- a. 0
- b. 4
- c. 1
- d. 5

23. Which of the following equations are quadratic equations?

(+1, -0.33)

- I) $x^2 + 4x + 23 = x + 33 / 28$
- II) $2x^2 / 3 + 6x + 2 = x^2 + 8$
- III) $6x^2 + 4x + 18 = 6x^2 - 6x$

- a. I & II
 - b. I, II & III
 - c. I & III
 - d. II & III
-

24. Nuclear fission can be controlled by using control rods made up of: (+1, -0.33)

- a. Calcium
 - b. Magnesium
 - c. Boron
 - d. Aluminium
-

25. Which of the following is an irrational number? (+1, -0.33)

- a. $6/15$
 - b. $\pi/\sqrt{3}$
 - c. -1
 - d. $4/15$
-

26. In a triangle ABC, the length of the side AB, is 2 cm, the angle at C is 60° and the angle at B is 30° , what is the length of side AC? (+1, -0.33)

- a. $\sqrt{2}$ cm
- b. $2/\sqrt{3}$ cm

- c. $\sqrt{3}$ cm
- d. $\sqrt{3} / 2$ cm

27. A cyclist starting from point X travels straight towards east for 3km and then turns right and covers 4km and reaches point Y. What is the shortest distance between point X and Y? (+1, -0.33)

- a. 5 km
- b. 2 km
- c. 7 km
- d. 1 km

28. Biogas is a mixture of gases produced during decomposition of biomass necessarily in the: (+1, -0.33)

- a. absence of oxygen
- b. presence of hydrogen
- c. absence of hydrogen
- d. presence of oxygen

29. A train is approaching a station with a uniform velocity of 72 kmph and the frequency of the whistle of that train is 480 Hz. The apparent increase in the frequency of that whistle heard by a stationary observer on the platform is (Velocity of sound in air is 340 m/s). (+1, -0.33)

- a. 45 Hz

- b. 15 Hz
- c. 60 Hz
- d. 30 Hz

-
30. To keep a particle moving with constant velocity on a frictionless surface, an external force: (+1, -0.33)
- a. should act continuously
 - b. should act opposite to the direction of motion
 - c. is not necessary
 - d. should be of variable magnitude

-
31. In a right-angle triangle, right-angled at A, the angle formed at B is 45° , if the length of side AB is 3 cm, then what is the length of the side BC? (+1, -0.33)
- a. $3\sqrt{2}$ cm
 - b. 2 cm
 - c. 3 cm
 - d. 1.5 cm

-
32. Find the sum of zeros for the quadratic polynomial $3x^2 + 5x - 2$ (+1, -0.33)
- a. $-3/5$
 - b. $5/3$

c. $3/5$

d. $-5/3$

33. The radius of curvature of a spherical mirror is 20 cm. Its focal length is: **(+1, -0.33)**

a. 20 cm

b. 40 cm

c. 10 cm

d. 30 cm

34. In a right-angled triangle, with right angle at A being the side AB is of length 4 cm and BC is 15 cm. what is the length of side AC? **(+1, -0.33)**

a. $\sqrt{15}$ cm

b. 14 cm

c. $\sqrt{209}$ cm

d. 2.09 cm

35. When light travels from one medium to another, which of the following does not change? **(+1, -0.33)**

a. Wavelength

b. Intensity

c. Velocity

d. Frequency

36. Consider a circular loop of wire lying on the plane of a table. Let an electric current pass through the loop clockwise. The direction of the magnetic field inside is: (+1, -0.33)

- a. perpendicular to the plane of the table pointing into it
 - b. always along the tangent to the loop in the same sense of flow of the current
 - c. perpendicular to the plane of the table and appearing to emerge out from it
 - d. always along the tangent to the loop opposite to the sense of flow of the current
-

37. 19 defective pens have accidentally got mixed with 361 good ones. It is not possible to just look at a pen and tell whether or not it is defective. One pen is taken out at random from this lot. Determine the probability that the pen taken out is a defective one. (+1, -0.33)

- a. $1 / 20$
 - b. $1 / 10$
 - c. $2 / 19$
 - d. $1 / 19$
-

38. As we move from the equator towards the N-pole, while remaining on the surface of earth the value of g (+1, -0.33)

- a. increases and decreases periodically
 - b. increases
 - c. does not change
 - d. decreases
-

39. The region surrounding a magnet in which its influence can be felt is called its: (+1, -0.33)

- a. magnetic induction
 - b. magnetic screen
 - c. magnetic field
 - d. magnetic flux
-

40. Triangles PQR and BAC are similar triangles. (+1, -0.33)

Triangles BAC have the following sides.

$AB = 36 \text{ cm}$

$BC = 20 \text{ cm}$

$CA = 48 \text{ cm}$

Triangle PQR have the following sides:

$PQ = 9 \text{ cm}$

$PR = 5 \text{ cm}$

What is the length of side RQ = ?

- a. 30 cm
 - b. 15 cm
 - c. 3 cm
 - d. 12 cm
-

41. Find the roots of the following equation:

(+1, -0.33)

$$4x^2 + 4x - 3 = 0$$

- a. $-3/2, 1/2$
 - b. $-3/2, -1/2$
 - c. $3/2, 1/2$
 - d. $3/2, -1/2$
-

42. A person wears glasses of power $-2.5D$. Tell whether the person is long-sighted or near-sighted and find the far point of the person without glasses

(+1, -0.33)

- a. near-sighted, -20 cm
 - b. long-sighted, -20 cm
 - c. near-sighted, -40 cm
 - d. long-sighted, -40 cm
-

43. The dimensional formula of force:

(+1, -0.33)

- a. $[ML^{-3}T^2]$
- b. $[MLT^{-2}]$
- c. $[ML^{-2}T^{-2}]$
- d. $[ML^{-1}T^{-1}]$

44. The diameter of a copper sphere is 12 cm. The sphere is melted and is drawn into a long wire of uniform circular cross-section. If the length of wire is 48 cm, find its diameter. (+1, -0.33)

- a. $3\sqrt{6}$ cm
- b. $2\sqrt{6}$ cm
- c. $\sqrt{6}$ cm
- d. 6 cm

45. A horizontal force F produces an acceleration of $6m/s^2$ on a block resting on a smooth horizontal surface. The same force produces an acceleration of $3m/s^2$ on a second block resting on a smooth horizontal surface. If the two blocks are tied together and the same force acts, the acceleration produced will be (+1, -0.33)

- a. $1m/s^2$
- b. $2m/s^2$
- c. $4.5m/s^2$
- d. $9m/s^2$

46. A hemispherical depression is cut out from one face of a cubical wooden block such that the diameter l cm of the hemisphere is equal to the edge of the cube. Determine the surface area of the remaining solid. (+1, -0.33)

- a. $\frac{1}{2}l^2 (12 + \pi) \text{ cm}^2$
- b. $\frac{1}{4}l^2 (24 + \pi) \text{ cm}^2$
- c. $\frac{1}{3}l^2 (18 + \pi) \text{ cm}^2$
- d. $\frac{1}{4}l^2 (18 + \pi) \text{ cm}^2$

47. Find the roots of the following quadratic polynomial $x^2 - 2x - 15$ (+1, -0.33)

- a. 3, 5
- b. -3, -5
- c. -3, 5
- d. 3, -5

48. Which of the following is dimensionless? (+1, -0.33)

- a. Velocity
- b. Angle
- c. Mass
- d. Area

49. What is the area of the triangle in sq. cm with a base of 10 cm and sides of length 6 cm each? (+1, -0.33)

- a. $5\sqrt{11}$
- b. 11.5
- c. 55
- d. $11\sqrt{5}$

50. A constant force (F) is applied on a stationary particle of mass ' m '. The velocity attained by the particle after a certain displacement will be proportional to (+1, -0.33)

- a. $\frac{1}{\sqrt{m}}$
- b. m
- c. $1/m$
- d. \sqrt{m}

51. Find the distance between the points $(2, 0, 2)$ and $(-2, 2, -2)$ (+1, -0.33)

- a. $\sqrt{3}$
- b. 3
- c. $\sqrt{6}$
- d. 6

52. The distance covered by a particle in time ' t ' is given by $s = at + bt^2$ where ' a ' and ' b ' are two constants. The dimensional formula of ' b ' is: (+1, -0.33)

- a. $[M^0 L^1 T^{-2}]$

b. $[M^0 L^2 T^{-1}]$

c. $[M^0 L^1 T^{-1}]$

d. $[M^0 L^2 T^{-2}]$

53. A person moves 30m north and then 20m towards east and finally $30\sqrt{2}$ in south-west direction. The displacement of the person from the origin will be (+1, -0.33)

a. 10 m along south

b. 10 m along west

c. 10 m along north

d. zero

54. An electric iron of resistance 20 ohm takes a current of 5 A. The heat flow in 30 s is: (+1, -0.33)

a. $1.5 \times 10^4 J$

b. $2.5 \times 10^2 J$

c. $1.5 \times 10^5 J$

d. $1.5 \times 10^2 J$

55. A rope of length 10 m and linear density of 0.5 kg/m is lying lengthwise on a smooth horizontal floor. It is pulled by a force of 25 N. The tension in the rope at a point 6 m away from the point of application is: (+1, -0.33)

a. 10 N

- b. 20 N
- c. 15 N
- d. 5 N

56. The resistance of a metallic wire of length 1m and area of cross-section 1sq.metre having a resistivity is $2 \times 10^{-6} \text{ ohm -m}$ is: (+1, -0.33)

- a. $2 \times 10^{-6} \text{ ohm}$
- b. $0.5 \times 10^6 \text{ ohm}$
- c. $1 \times 10^{-6} \text{ ohm}$
- d. $0.25 \times 10^{-6} \text{ ohm}$

57. A body is allowed to slide down a frictionless track from rest position at its top under gravity. The track ends in a circular loop of diameter D. Then, the minimum height of the inclined track (in terms of D) so that it may complete successfully the loop is (+1, -0.33)

- a. $3D/4$
- b. $9D/4$
- c. $5D/4$
- d. $7D/4$

58. A man weighs 'W' on the surface of earth and his weight at a height '2R' from surface of earth is (R is the Radius of earth). (+1, -0.33)

- a. $\frac{w}{9}$

b. $\frac{w}{6}$

c. W

d. $\frac{w}{3}$

59. What is the angle at B in the triangle ABC, if the angle made at K is 30° and the triangles shown in the figure are similar (+1, -0.33)

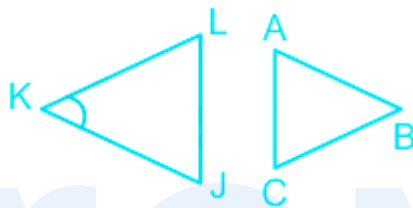

a. 20°

b. 60°

c. 70°

d. 30°

prepp
Your Personal Exams Guide

60. Solutions for the following pair of equations would be (+1, -0.33)

$$x + 2y = 6,$$

$$x - 2y = 16$$

a. $x = -11, y = -2 / 5$

b. $x = -11, y = 2 / 5$

c. $x = 11, y = -5 / 2$

d. $x = 11, y = 5 / 2$

61. In a triangle the length of the sides, AB is 3 cm and BC is 5 cm what is the length of AC, if the angle formed at B is 60° . (+1, -0.33)

- a. 4 cm
- b. 19 cm
- c. 3 cm
- d. $\sqrt{19}$ cm

62. An object is placed at a distance of 10 cm from a convex mirror of focal length 15 cm. The magnification is: (+1, -0.33)

- a. +0.3
- b. +0.6
- c. -0.3
- d. -0.6

63. Near and far points of healthy human eye respectively are: (+1, -0.33)

- a. 25 cm and 100 cm
- b. 25 cm and infinity
- c. 0 and infinity
- d. 0 and 25 cm

64. The nature of the image formed by a concave mirror if the magnification produced by the mirror is +3 is: (+1, -0.33)

- a. virtual, erect and diminished
 - b. real, inverted and enlarged
 - c. real, inverted and diminished
 - d. virtual, erect and enlarged
-

65. What is the common difference of the following A.P. series? (+1, -0.33)

7, 19, 31, 43,

- a. 19
 - b. 5
 - c. 12
 - d. 7
-

66. Find a point on the Y axis which is equidistant from A(2, -3) and B(-2, 1) (+1, -0.33)

- a. P(0, -1)
 - b. P(0, -2)
 - c. P(0, 1)
 - d. P(0, 2)
-

67. Which of the following is a rational number? (+1, -0.33)

- a. $\sqrt{3}$
 - b. $4 - 6i$
 - c. 2
 - d. $7i$
-

68. A at disco the beam revolves 360° in 20 minutes. Its maximum coverage is 20 m long. After 2 minutes what length the beam would have covered from its starting point? (+1, -0.33)

- a. 2π m
 - b. 4π m
 - c. 4 m
 - d. 2 m
-

69. What is the area of this parallelogram is sq.cm.? The measurements are in cm. (+1, -0.33)

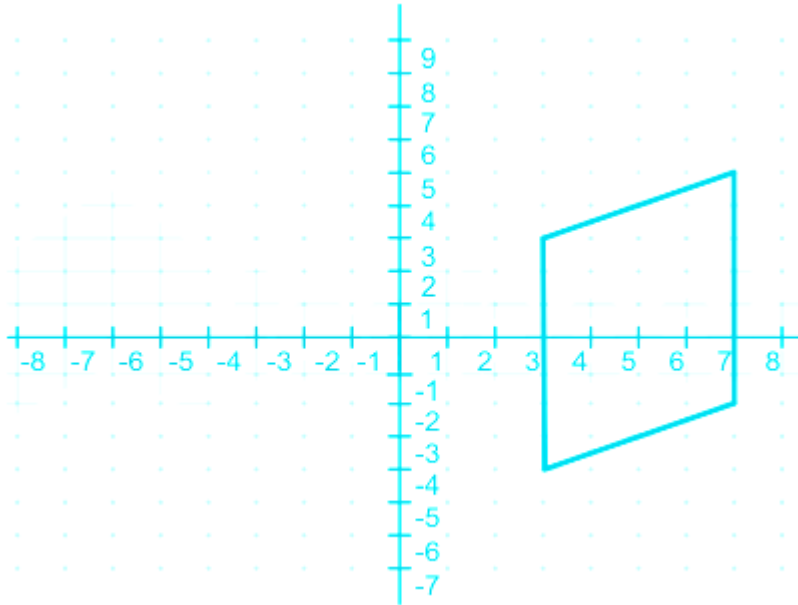

- a. 24
- b. 28
- c. 8
- d. 16

prepp

Your Personal Exams Guide

70. Sound waves are _____ waves, and light waves are _____. (+1, -0.33)

- a. Longitudinal mechanical, transverse mechanical
- b. Longitudinal electromagnetic, transverse mechanical
- c. Longitudinal mechanical, transverse electromagnetic
- d. Longitudinal electromagnetic, transverse electromagnetic

71. What is the value of $(6 + 3i) + (2 + 5i)$? (+1, -0.33)

- a. $8 + 8i$

b. $12 + 15i$

c. $4 + 2i$

d. $4 - 2i$

72. Keeping the speed of projection constant, the angle of projection is increased from 0° to 90° . Then the horizontal range of the projectile (+1, -0.33)

a. increases up to 45° and decreases afterwards

b. increases up to 60° and decreases later

c. increases up to 45° and remains unaltered thereafter

d. goes on increasing up to 90°

73. The 5th and the 17th terms of an A.P. series are 52 and 184 respectively. Find the common difference of the series. (+1, -0.33)

a. 7

b. 5

c. 11

d. 9

74. Two plates with diameters 3.5 cm and 2.5 cm are kept one above the other. The larger plate is placed at the bottom. What is the total area of the larger plate in sq. cm that is visible? (+1, -0.33)

a. 2π

- b. π
 - c. 1.5π
 - d. 2.5π
-

75. Average Acceleration=

(+1, -0.33)

- a. $\frac{\text{Total displacement}}{\text{total time}}$
- b. $\frac{\text{change in velocity}}{\text{time taken}}$
- c. $\frac{\text{distance}}{\text{time}}$
- d. $\frac{\text{change in mass}}{\text{time}}$

prepp

Your Personal Exams Guide

Answers

1. Answer: b

Explanation:

Given:

$$x + 2y = 12,$$

$$4x + 8y = 48$$

Calculation:

$$a_1x + b_1y = c_1 \text{ and } a_2x + b_2y = c_2$$

$$\Rightarrow 2y = -x + 12$$

$$\Rightarrow y = -(1/2)x + 6 \quad \text{---(i)}$$

$$\Rightarrow y = -(4/8)x + (48/8)$$

$$\Rightarrow y = -(1/2)x + 6 \quad \text{---(ii)}$$

Equations (i) and (ii) are same

\therefore Lines are coincident with each other

★ Alternate Method

Two lines are coincident when:

$$\frac{a_1}{a_2} = \frac{b_1}{b_2} = \frac{c_1}{c_2}$$

$$1/4 = 2/8 = 12/48$$

Hence the above lines are coincident

2. Answer: c

Explanation:

Given: central angle of 30° intercepts an arc of length 2 cm

Formula Used: $\theta = \text{arc} / \text{radius}$ and $1^\circ = \pi^\circ / 180$

Calculation: using the above formulae, we get $\theta = \pi / 6$

$$\Rightarrow \pi / 6 = 2 / \text{radius}$$

$$\Rightarrow \text{radius} = 12 \times 7 / 22 \text{ cm}$$

$$\therefore \text{required radius} = 3.82 \text{ cm}$$

3. Answer: c

Explanation:

CONCEPT:

- Concave mirror: If the inner surface of the spherical mirror is the reflecting surface, then it is called a concave mirror. It is also called a focusing mirror/converging mirror.
 - The size of the image produced by these mirrors can be larger or smaller than the object, depending upon the distance of the object from the mirror.
 - The concave mirror can form both real as well as virtual images of any object.
- Mirror formula: The expression which shows the relation between object distance (u), image distance (v), and focal length (f) is called mirror formula.

$$\frac{1}{v} + \frac{1}{u} = \frac{1}{f}$$

Linear magnification (m):

- It is defined as the ratio of the height of the image (h_i) to the height of the object (h_o).

$$m = \frac{h_i}{h_o}$$

- The ratio of image distance to the object distance is called linear magnification.

$$m = \frac{\text{image distance } (v)}{\text{object distance } (u)} = -\frac{v}{u}$$

CALCULATION:

Given - $m = 3$ and object distance (u) = - 10 cm

- The ratio of image distance to the object distance is called linear magnification.

$$\Rightarrow m = \frac{\text{image distance } (v)}{\text{object distance } (u)} = -\frac{v}{u}$$

$$\Rightarrow 3 = -\frac{v}{-10}$$

$$\Rightarrow m = -30 \text{ cm}$$

- Here **magnification is greater than 1**, which means the image formed is enlarged, therefore an **inverted image** is formed at a distance of 30 cm in front of the given concave mirror. Therefore option 3 is correct.

Your Personal Exams Guide

4. Answer: d

Explanation:

Given:

$$BC = 5.2 \text{ cm}$$

$$AB = 3 \text{ cm}$$

Calculation:

$$\sec \theta = \text{hypotenuse} / \text{base}$$

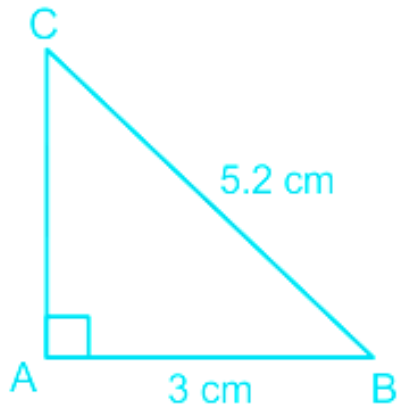

So, $\sec B = 5.2 / 3$

$\approx 1.7 \text{ cm}$

\Rightarrow required result = 1.7 cm

5. Answer: d

Explanation:

Given:

Distance between men and the wall = 500 cm

Angle of elevation of hook of wall = 45°

Concept:

$90^\circ 45^\circ 45^\circ$ rule

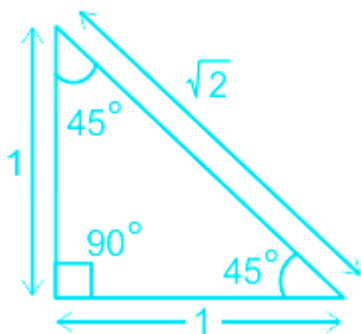

Calculation:

So by, 45° 45° 90° rule

In ΔABC

$AB = BC = 500$ cm

Height of wall =

$\Rightarrow 500 + 165 = 665$ cm

\Rightarrow required height of wall = 665 cm

6. Answer: c

Explanation:

Given:

20, 18, 16, 25, 19, 22, 18, 16, 23, 14

Formula used:

Mean = sum of numbers given in data / total number

Calculation:

$\Rightarrow (20 + 18 + 16 + 25 + 19 + 22 + 18 + 16 + 23 + 14) / 10$

$\Rightarrow 191 / 10$

$\Rightarrow 19.1$

7. Answer: c

Explanation:

CONCEPT :

Acceleration Due to Gravity :

- The force of attraction exerted by the earth on a body is called gravitational pull or gravity .
- We know that when a force acts on a body , it produces acceleration . Therefore, a body under the effect of gravitational pull must accelerate .
- The acceleration produced in the motion of a body under the effect of gravity is called acceleration due to gravity , it is denoted by g .
- The acceleration due to gravity on the surface of the earth is given by,

$$g = \frac{GM}{R^2}$$

Where G = universal gravitational constant, M = mass of the earth and R = radius of the earth

CALCULATION :

Given - The acceleration due to gravity on the surface of the earth is (g_e) = 10 m/s^2

- The acceleration due to gravity on the surface of the earth is given by,

$$\Rightarrow g_e = \frac{GM}{R^2} \quad \text{----- (2)}$$

- Acceleration due to gravity at height h from the surface of the earth -

$$\Rightarrow g_h = \frac{GM}{(R+h)^2} \quad \text{----- (2)}$$

On dividing equations 1 and 2, we get

$$\Rightarrow \frac{g_e}{g_h} = \frac{\frac{GM}{R^2}}{\frac{GM}{(R+h)^2}} = \frac{(R+h)^2}{R^2}$$

$$\Rightarrow \frac{10}{g_h} = \frac{(6400+6400)^2}{6400^2} = 4$$

$$\Rightarrow g_h = 10/4 = 2.5 \text{ m/s}^2$$

8. Answer: b

Explanation:

Given:

Internal radius of sphere = 4 cm

External radius of sphere = 6 cm

Formula used:

Here, Volume of sphere = $(4 / 3) \pi \times (\text{External radius}^3 - \text{Internal radius}^3)$

Volume of cylinder = $\pi \times \text{radius}^2 \times \text{height}$

Calculation:

$$\Rightarrow (4 / 3) \pi \times [(6)^3 - (4)^3] = \pi \times \text{radius}^2 \times (4 / 3)$$

$$\Rightarrow r = 2\sqrt{38}$$

$$\Rightarrow \text{Diameter of cylinder} = 2 \times 2\sqrt{38} = 4\sqrt{38} \text{ cm}$$

Your Personal Exams Guide

9. Answer: b

Explanation:

CONCEPT:

- Work-energy theorem: It states that work done by a force acting on a body is equal to the change in the kinetic energy of the body i.e.,

$$W = K_f - K_i$$

$$W = \frac{1}{2}mv^2 - \frac{1}{2}mu^2 = \Delta K$$

Where v = final velocity, u = initial velocity and m = mass of the body

CALCULATION:

Given - Initial velocity of the car in the 1st case (u_1) = 36 km/hr = 10 m/s, distance in 1st case (s_1) = 5 m, initial velocity of the car in the 2nd case (u_2) = 72 km/hr = 20 m/s and final velocity in both case is 0 m/s

- Since the braking force is the same in both cases, therefore the **work done by the brakes** in stopping the car in 1st case is

$$\Rightarrow F \times 5 = \frac{1}{2} \times m \times 10^2 \quad \text{----- (1)}$$

- The work done by the brakes in stopping the car in 2nd case is

$$\Rightarrow F \times s = \frac{1}{2} \times m \times 20^2 \quad \text{----- (2)}$$

On dividing equation 1 and 2, we get

$$\Rightarrow \frac{5}{s} = \frac{100}{400} = \frac{1}{4}$$

$$\Rightarrow s = 20 \text{ m}$$

10. Answer: b

Explanation:

Given:

2, 5, 8, 11, 14,

Formula used:

$$a_n = \{a_1 + (n - 1)d\}$$

a_1 = 1st number

n = last number

d = difference between the number

Solution:

$$\Rightarrow \{2 + (177) \times 3\}$$

$$\Rightarrow 2 + 531$$

$$\Rightarrow 533$$

11. Answer: a

Explanation:

Given:

Ratio of area of BAC and RAQ = 2 : 1

Area of BAC = 100 cm^2

Concept:

Basic proportionality theorem:

If a line is parallel to the side of triangle which intersects other two side in distinct point, then the line divides the other two sides in proportional

Calculation:

According basic proportionality theorem

Area of BAC = 100 cm^2

Ratio of BAC and RAQ = 2:1

Area of RAQ and RBCQ = 1:1

\therefore area of RAQ = 50 cm^2

12. Answer: a

Explanation:

Given:

$$x^3 - 6x^2 + 11x - 6$$

one root of the equation = 2

Calculation:

$$\Rightarrow (x^3 - 6x^2 + 11x - 6) / (x - 2)$$

$$\Rightarrow (x - 1)(x - 3)(x - 2) / (x - 2)$$

$$\Rightarrow (x - 3)(x - 1)$$

$$\Rightarrow x = 3, 1$$

13. Answer: d

Explanation: Your Personal Exams Guide

CONCEPT:

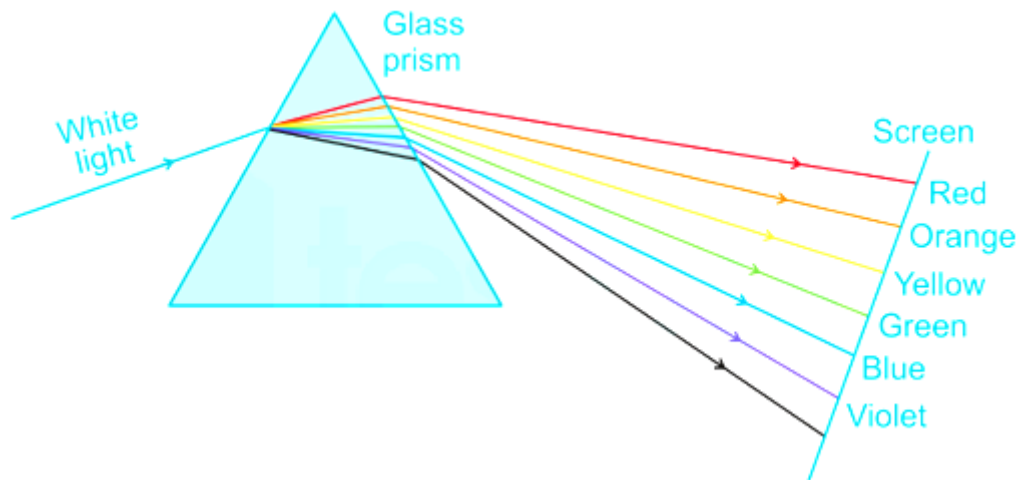

- The splitting of a composite beam of light into its constituent colours is called dispersion of light.
- The dispersion of white light occurs because the colours of white light travel at different speeds through the glass prism .
- The dispersion was discovered by Sir Issac Newton .
- Newton discovered that light is made up of seven different colours .

EXPLANATION:

- As we know that, the refractive index is defined as the ratio of the speed of light in a vacuum to the medium i.e.,

$$\text{Refractive index } (\mu) = \frac{\text{Speed of light in vacuum}(C)}{\text{Speed of light in a medium}(v)}$$

- According to Cauchy's formula , refractive index (μ) of a material depends on the wavelength (λ) of light falling on it as

$$\Rightarrow \mu = A + \frac{B}{\lambda^2} + \frac{C}{\lambda^3} + \dots$$

Where A, B, C..... are constants.

- From the above relation, it is clear that the refractive index is inversely proportional to the wavelength of the light used .
- As the **refractive index (μ) of the prism is different for different colours** , therefore the **speed of light will be different for different colors** thus, they **deviate through different angles** on passing through the prism. Hence, they are **seen as separate** .

14. Answer: d

Explanation:

CONCEPT:

- Work-energy theorem: It states that work done by a force acting on a body is equal to the change in the kinetic energy of the body i.e.,

$$W = K_f - K_i$$

$$W = \frac{1}{2}mv^2 - \frac{1}{2}mu^2 = \Delta K$$

Where v = final velocity, u = initial velocity and m = mass of the body

CALCULATION:

Given - Kinetic energy is same in both i.e., $KE_L = KE_C$ case and Final velocity in both cases is 0 m/s

- Since the **retarding force** is the **same in both cases**, therefore the work done by the retarding force in stopping the lorry is

$$\Rightarrow F \times s_1 = \Delta KE_L \quad \text{----- (1)}$$

- The work done by the retarding force in stopping the car is

$$\Rightarrow F \times s_2 = \Delta KE_C \quad \text{----- (2)}$$

On dividing equation 1 and 2, we get

$$\Rightarrow \frac{F \times s_1}{F \times s_2} = \frac{\Delta KE_L}{\Delta KE_C} = 1 \quad [\because KE_L = KE_C]$$

$$\Rightarrow s_1 = s_2$$

- Both lorry and car will come to rest at the **same distance**. Therefore option 4 is correct.

15. Answer: a

Explanation:

CONCEPT:

- Electric Power : The rate at which electrical energy is dissipated into other forms of energy is called electrical power i.e.,

$$P = \frac{W}{t} = VI = I^2 R = \frac{V^2}{R}$$

Where V = Potential difference, R = Resistance and I = current.

EXPLANATION:

- Mathematically power can be written as,

$$\Rightarrow P = \frac{W}{t} = VI$$

If, W = 1 J and t = 1 sec, then P = 1 watt

- Thus the **power of an electric circuit** is said to be **one watt or 1 ampere - volt** if **one joule of energy** is consumed in **one second**. Therefore option 1 is correct.

16. Answer: a

Explanation:

CONCEPT:

- Ohm's law: At constant temperature, the potential difference across a current-carrying wire is directly proportional to the current flowing through it.

$$\text{i.e. } V = IR$$

Where V = potential difference, R = resistance and I = current .

EXPLANATION:

- According to ohm's law, $V = IR$

The above equation can be written for resistance as

$$\Rightarrow R = \frac{V}{I}$$

- Therefore the **resistance** is defined as the **ratio of potential difference across the terminals of a conductor to the current** flowing through it. Therefore option 1 is correct.

- The **resistivity of a material** is the **resistance of a wire** of that material of **unit length and unit cross-sectional area**. Therefore option 2 is incorrect.
- **Conductivity** is the measure of the **ease at which an electric charge or heat can pass through a material**. Therefore option 3 is incorrect.
- The **reciprocal of electrical resistance** is called **conductance**. Therefore option 4 is incorrect.

17. Answer: d

Explanation:

Given:

Angle of elevation = 60°

Length of candle = 21 cm

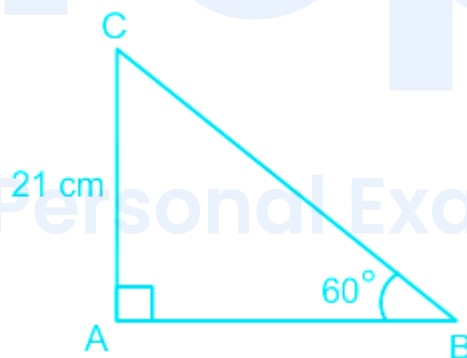

$$\tan 60^\circ = \sqrt{3}$$

$$\tan \theta = \text{perpendicular} / \text{base}$$

According to question:

$$\tan 60^\circ = \text{height of candle} / \text{distance of tip of candle shadow to its base}$$

$$\Rightarrow \sqrt{3} = 21 / \text{distance of tip of candle shadow to its base}$$

$$\Rightarrow \text{Distance of tip of candle shadow to its base} = 21 / \sqrt{3}$$

⇒ Distance of tip of candal shadow to its base = $(21\sqrt{3}) / \sqrt{3}$

⇒ Distance of tip of candal shadow to its base = $7\sqrt{3}$ cm

18. Answer: b

Explanation:

Given:

$$x^2 + 12x - 36 = 0$$

Formula used:

$$\left[\frac{-b \pm \sqrt{b^2 - 4ac}}{2a} \right]$$

Calculation:

$$a = 1$$

$$b = 12$$

$$c = -36$$

$$\Rightarrow \left\{ \frac{-12 \pm \sqrt{144 + 4(36)}}{2 \times 1} \right\}$$

$$\Rightarrow \left\{ \frac{-12 \pm \sqrt{288}}{2} \right\}$$

$$\Rightarrow \left\{ \frac{-12 + 12\sqrt{2}}{2}, \frac{-12 - 12\sqrt{2}}{2} \right\}$$

$$\Rightarrow \{-6 + 6\sqrt{2}, -6 - 6\sqrt{2}\}$$

$$\Rightarrow -6(1 + \sqrt{2}), 6(\sqrt{2} - 1)$$

19. Answer: c

Explanation:

Concept:

Even prime number = 2

There are six faces of a dice. Each face is numbered from 1 to 6

Calculation

In a single throw

Total number of outcomes = 6

Total number of favorable outcomes = 1

(As even prime is the number is only one)

∴ Probability of getting even prime number = $1/6$

20. Answer: a

Explanation:

CONCEPT:

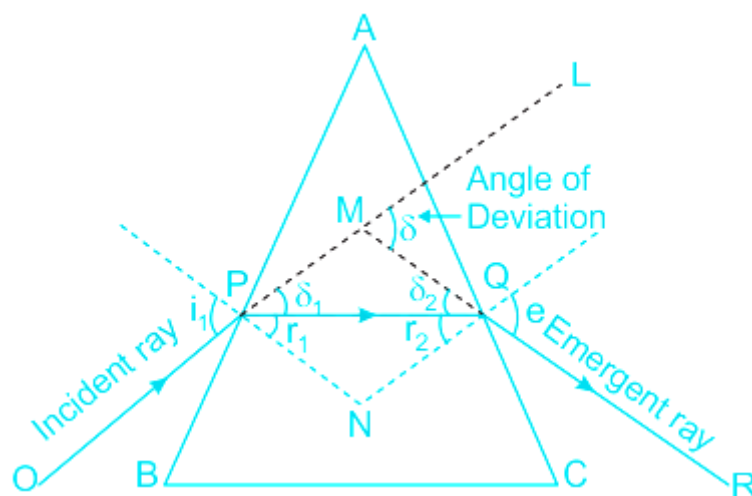

- The above figure shows the schematic diagram of the **refraction of light in a prism**.
- The **angle of minimum deviation** is defined as the **smallest angle through which light is bent by a prism**.
- The relationship between the **angle of minimum deviation and angle of the prism** is given by

$$\Rightarrow \delta = (\mu - 1)A$$

Where δ = Angle of minimum deviation, A = Angle of the prism, and μ = Refractive index

CALCULATION:

- Given - Refractive index of the first prism (μ_1) = 1.54, Refractive index of the second prism (μ_2) = 1.72, and the angle of the first prism (A_1) = 4°
- Let δ_1 and δ_2 be the angles which represent **the total deviation**
- According to question dispersion without deviation

$$\Rightarrow \delta_1 = \delta_2 \text{ -----(1)}$$

- We know

$$\Rightarrow \delta_1 = (\mu_1 - 1)A_1$$

Similarly, $\delta_2 = (\mu_2 - 1)A_2$

Substituting these values into equation 1

$$\Rightarrow (\mu_1 - 1)A_1 = (\mu_2 - 1)A_2 \text{ -----(2)}$$

Substituting the given values into equation 2

$$\Rightarrow (1.54 - 1)4^\circ = (1.72 - 1)A_2$$

$$\Rightarrow 0.54 \times 4^\circ = 0.72 \times A_2$$

$$\Rightarrow A_2 = \frac{0.54 \times 4^\circ}{0.72} = 3^\circ$$

- The value of $A_2 = 3^\circ$

21. Answer: c

Explanation:

Given:

$$21 \times (23 - 12) - ((-1 \times 10) + 21)$$

Concept:

Follow BODMAS rule to solve this question, as per the order given below.

Step - 1: Parts of an equation enclosed in 'Brackets' must be solved first, and following BODMAS rule in the bracket -

Step - 2: Any mathematical 'Of' or 'Exponent' must be solved next.

Step - 3: Next, the parts of the equation that contain 'Division' and 'Multiplication' are calculated.

Step - 4: Last but not the least, the parts of the equation that contain 'Addition' and 'Subtraction' should be calculated. Given expression is

$$21 \times (23 - 12) - [(-1 \times 10) + 21]$$

Calculation:

$$\Rightarrow 21 \times (11) - [-10 + 21]$$

$$\Rightarrow 231 - 11$$

$$\Rightarrow 220$$

\therefore the required answer = 220

22. Answer: a

Explanation:

Given:

$5i$

Concept:

$a + ib$

Here a = real part

b = imaginary part

$\therefore 0 + 5i$

Real part = 0

23. Answer: a

Explanation:

Since in equation III coefficient of x^2 is same in L.H.S and R.H.S and will cancel out each other so, it cannot be Quadratic equation

So, equation I and equation II are Quadratic equation

24. Answer: c

Explanation:

CONCEPT:

- The nucleus of a heavy atom (such as uranium, plutonium or thorium), when bombarded with low-energy neutrons, can be split apart into lighter nuclei. This process is called nuclear fission.
- Fission occurs when a neutron slams into a larger atom, forcing it to excite and split into two smaller atoms –also known as fission products.
- A chain reaction refers to a process in which neutrons released in fission reaction produces an additional fission reaction in at least one further nucleus. This nucleus, in turn, produces neutrons, and the process repeats.

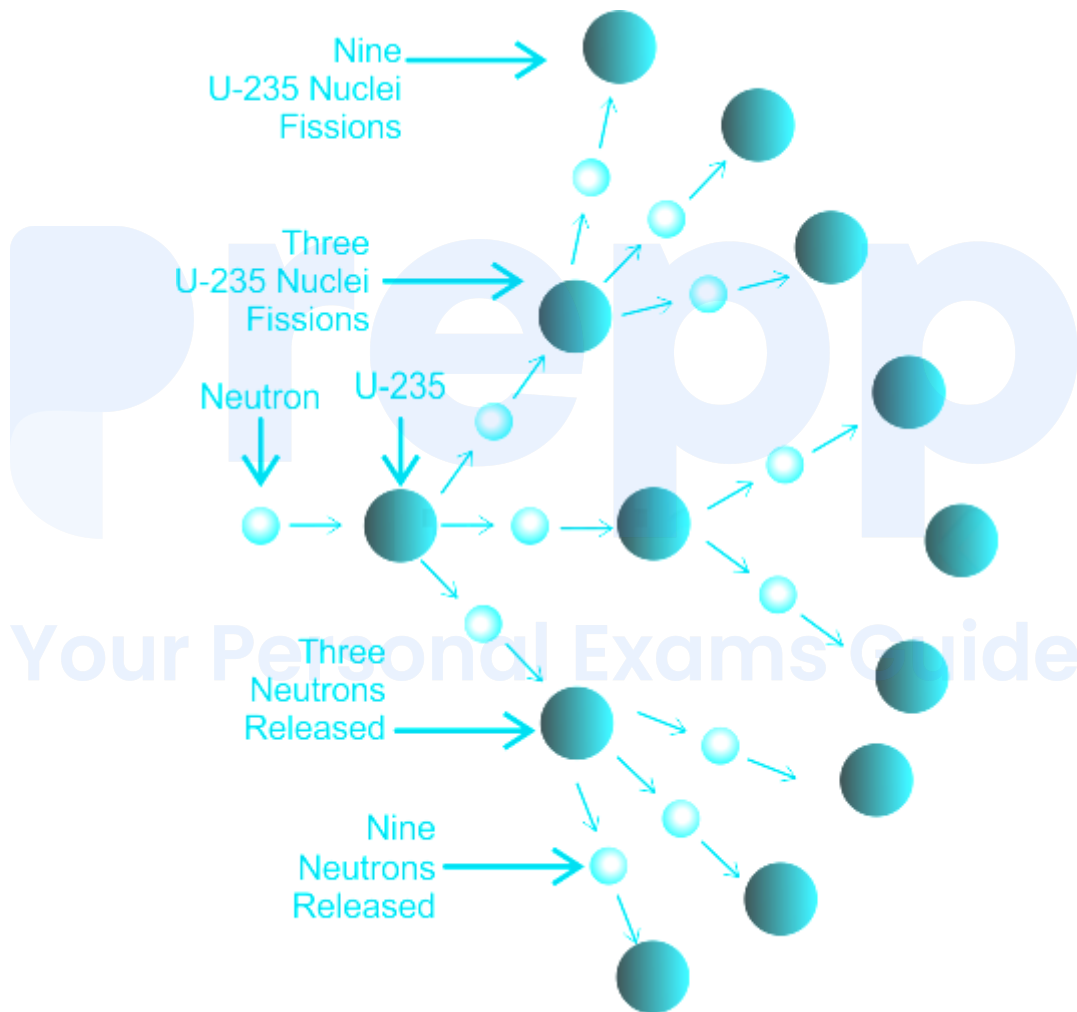

- During this reaction, a tremendous amount of energy is released.
- The nuclear reactors are controlled by means of control rods which are made of a strongly neutron-absorbent material such as boron or cadmium (Cd).

EXPLANATION:

- From above it is clear that, **nuclear fission** can be controlled by using control rods made up of boron or cadmium (Cd) . Therefore option 3 is correct.
-

25. Answer: b

Explanation:

Concept Used: In this type of question, An *Irrational Number* is a real number that cannot be written as a simple fraction

$\therefore \pi / \sqrt{3}$ is an *Irrational Number*

26. Answer: b

Explanation:

Given:

AB = 2 cm

C = 60°

B = 30°

Concept:

90° 30° 60° rule

prepp

Your Personal Exams Guide

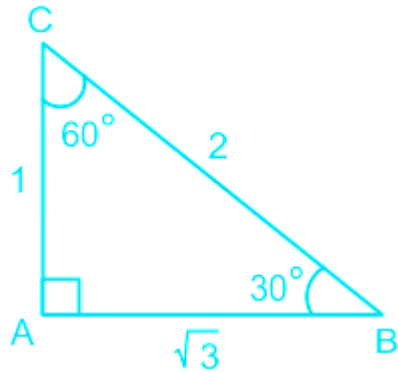

Calculation:

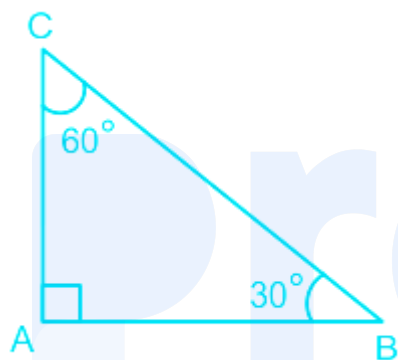

According to question:

$\Rightarrow AB = 2 \text{ cm}$

$\therefore AC = 2 / \sqrt{3} \text{ cm}$

\therefore required value of $AC = 2 / \sqrt{3} \text{ cm}$

27. Answer: a

Explanation:

CONCEPT:

Distance :

- The measurement of how much any object moved is called distance .

- It is a **scalar quantity** .

Displacement :

- The **minimum distance between two points** is called displacement of the object.
- It is a **vector quantity** .

CALCULATION:

Given - $OX = 3 \text{ km}$ and $OY = 4 \text{ km}$

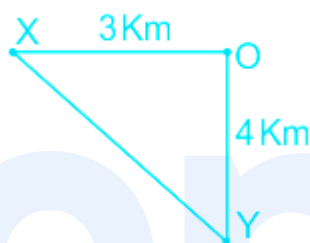

- The **shortest distance between point X and Y** is

$$\Rightarrow XY = \sqrt{OX^2 + OY^2}$$

$$\Rightarrow XY = \sqrt{3^2 + 4^2} = \sqrt{25} = 5 \text{ km}$$

★ Important Points

- The magnitude of displacement is equal to the minimum possible distance between two positions . So $\text{distance} \geq \text{Displacement}$.
- For a moving particle, distance can never be negative or zero while displacement can be (Zero displacement means that body after motion has come back to initial position). i.e., $\text{Distance} > 0$ but $\text{Displacement} > = \text{or} < 0$.
- For motion between two points displacement is single-valued while distance depends on the actual path and so can have many values.
- For a moving particle, distance can never decrease with time while displacement can .
- A decrease in displacement with time means the body is moving towards the initial position .

28. Answer: a

Explanation:

CONCEPT:

BIOGAS:

- **Biogas** is a mixture of gases produced by **anaerobic degradation of biomass** in the **presence of water but in the absence of oxygen**.
- It is a **renewable source of energy** on account of its production from vastly and continuous organic wastes.

EXPLANATION:

- From above it is clear that, **biogas** is a **mixture of gases** produced during decomposition of biomass necessarily in the **absence of oxygen**. Therefore option 1 is correct.
- **Biogas** is mainly composed of **methane (up to 75%)**, **CO₂ (25%)**, and traces of other gases such as **nitrogen and hydrogen**.
- Whereas **methane** is a **high-value calorific fuel**, **carbon dioxide** is an **inert gas**.

Your Personal Exams Guide

29. Answer: d

Explanation:

CONCEPT:

- Doppler Effect: An increase or decrease in the frequency of sound, light, or other waves that are observed by observer due to movement of the source and observer towards (or away from) each other is known as Doppler Effect.
- The apparent frequency heard by the observer is given by the formula:

$$f = f_0 \left(\frac{v - v_o}{v - v_s} \right)$$

Where f = apparent frequency, f_0 = original frequency of the source, v = speed of sound in air, v_s = speed of the source, v_o = speed of the observer.

- In this formula, if the source is not moving, we can put $v_s = 0$. and the same for the observer speed.

CALCULATION:

Given that $v_s = 72 \text{ km/hr} = 20 \text{ m/s}$; $f_0 = 480 \text{ Hz}$; $v = 340 \text{ m/s}$; $v_o = 0$

- The apparent frequency heard by the observer is given by the formula:

$$\Rightarrow f = f_0 \left(\frac{v - v_o}{v - v_s} \right)$$

$$\Rightarrow f = 480 \left(\frac{340}{340 - 20} \right)$$

$$\Rightarrow f = 510 \text{ Hz}$$

- The apparent increase in the frequency of that whistle heard by a stationary observer on the platform is

$$\Rightarrow \Delta f = (510 - 480) \text{ Hz} = 30 \text{ Hz}$$

Your Personal Exams Guide

30. Answer: c

Explanation:

CONCEPT:

Newton's First law :

- A body continues to be in its state of rest or of uniform motion along a straight line unless it is acted upon by some external force to change the state .
- If no net force acts on a body , then the velocity of the body cannot change i.e. the body cannot accelerate.

EXPLANATION:

- From above it is clear that, **no external force** is required to keep a particle moving with constant velocity on a frictionless surface. Therefore option 3 is correct.

31. Answer: a

Explanation:

Given:

$$\angle B = 45^\circ$$

$$AB = 3 \text{ cm}$$

Concept:

90° 45° 45° rule

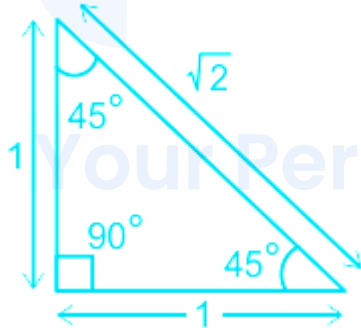

According to question:

$$AB = 3 \text{ cm}$$

So, by 90° 45° 45° rule

$$\Rightarrow BC = 3\sqrt{2} \text{ cm}$$

$$\therefore \text{required length of } BC = 3\sqrt{2} \text{ cm}$$

32. Answer: d

Explanation:

Given:

$$3x^2 + 5x - 2$$

Calculation:

$$3x^2 + 5x - 2$$

$$\Rightarrow 3x^2 + 6x - x - 2$$

$$\Rightarrow 3x(x + 2) - 1(x + 2)$$

$$\Rightarrow (x + 2)(3x - 1)$$

$$\Rightarrow x = -2, 1/3$$

According to question

$$\Rightarrow \text{sum of roots} = -2 + 1/3$$

$$\Rightarrow -5/3$$

33. Answer: c

Explanation:

CONCEPT:

- A spherical mirror is a mirror whose reflecting surface is a part of a hollow sphere of glass.
- One side of the mirror is well polished and reflecting, and another side of the mirror is opaque (often painted red).
- Spherical mirrors are of two types - Convex mirror, and Concave mirror.

- The image formed by the spherical mirrors depends on the position of the object.

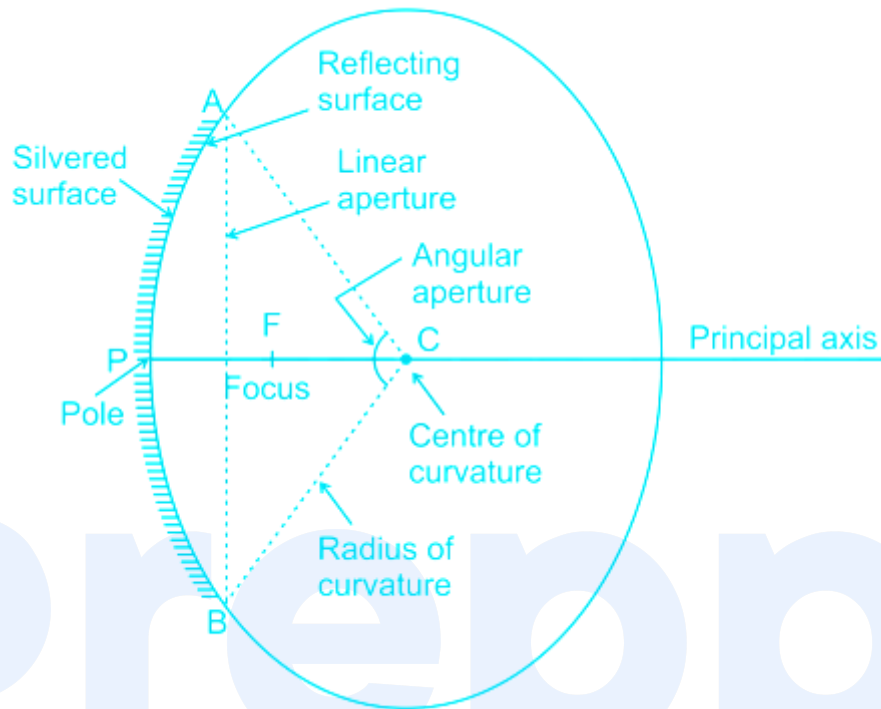

EXPLANATION:

Given - Radius of curvature (R) = 20 cm

- The relationship between the focal length (f) and the radius of curvature (R) is given by -

$$\Rightarrow f = \frac{R}{2}$$

$$\Rightarrow f = \frac{20}{2} = 10 \text{ cm}$$

34. Answer: c

Explanation:

Given:

$$AB = 4 \text{ cm}$$

$$BC = 15 \text{ cm}$$

Formula used:

$$CB^2 = AB^2 + AC^2$$

Calculation:

$$\Rightarrow 15^2 = 4^2 + AC^2$$

$$\Rightarrow 225 = 16 + AC^2$$

$$\Rightarrow AC^2 = 209$$

$$\Rightarrow AC = \sqrt{209} \text{ cm}$$

35. Answer: d

Explanation:

CONCEPT:

- Refraction of Light: The bending of the ray of light passing from one medium to the other medium is called refraction.

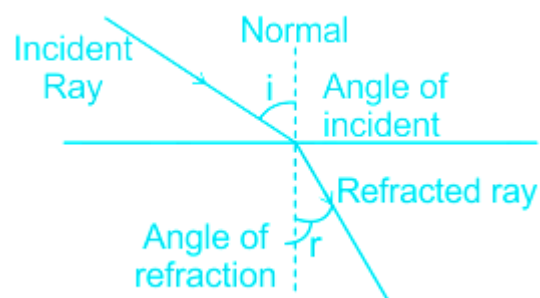

- The refraction of light takes place on going from one medium to another because the speed of light is different in the two media.
- Greater the difference in the speeds of light in the two media, greater will be the amount of refraction.

- A medium in which the speed of light is more is known as optically rarer medium and a medium in which the speed of light is less is known as an optically denser medium .

EXPLANATION:

- Whenever light goes from air to glass , the frequency of light and phase of light does not change . Therefore option 4 is correct.
- However, the velocity of light and wavelength of light change .

36. Answer: a

Explanation:

CONCEPT:

Right-hand thumb rule:

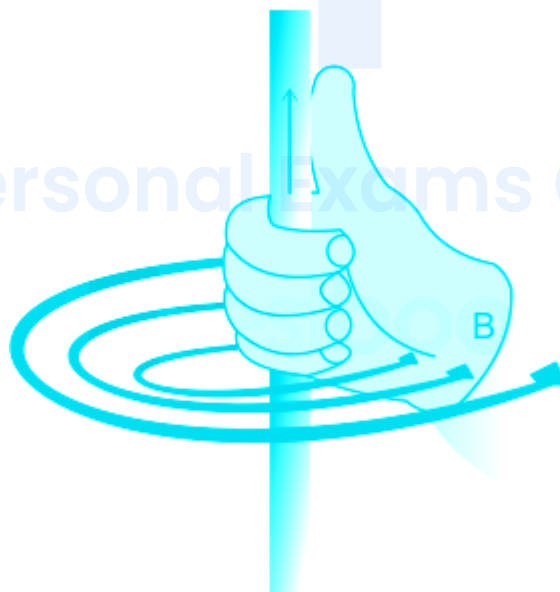

- **Right-hand thumb rule** states that if a current-carrying conductor is imagined to be held in the right hand such that the **thumb points in the direction of the current** , then the **curled fingers** indicate the **direction of the magnetic field** .
- If the **current flows in the upward direction** the **direction of the magnetic field is clockwise** , then the **direction facing will be the North Pole** .

- If the **current flows in the downward direction** the **direction of the magnetic field is anticlockwise**, then the **direction facing will be the South Pole**.

EXPLANATION:

Given - The current is passing through the loop in **clockwise**.

- Since the current passes through the **loop in the clockwise direction**, therefore, the **front face of the loop** will be the **south pole** and the **back face**, i.e., the face touching the table will be **north pole**.
- According to the right-hand rule, the **direction of the magnetic field inside the loop** will be **pointing downward**.
- Outside the loop, the **direction of the magnetic field** will be **upward**.

37. **Answer: a**

Explanation:

Given:

19 defective pen

361 good pen

Concept used:

Probability = (favourable numbers of observation) / (Total numbers of observations)

Calculation:

Total number of pen = $361 + 19 = 380$

Probability of taking out defective pen = favourable number of ways to take out defective pen / total number of outcome

Number of favourable ways to take out defective pen = 19

Total number of outcome = 380

⇒ Probability of taking out defective pen = $19 / 380 = 1/20$

∴ The probability of taking out the defective pen is $1/20$

38. Answer: b

Explanation:

CONCEPT:

Acceleration due to gravity (g):

- The force of attraction exerted by the earth on a body is called gravitational pull or gravity.
- We know that when a force acts on a body, it produces acceleration.
- Therefore, a body under the effect of gravitational pull must accelerate.
- Acceleration due to gravity at the surface of the earth is given by:

$$g = \frac{GM}{R^2}$$

Where G = Universal gravitational constant, M = mass of the earth, and R = radius of the earth.

EXPLANATION:

- As Earth is elliptical in shape i.e., it is flattened at the poles and bulged out at the equator, due to which the equatorial radius is about 21 km longer than the polar radius.
- As the polar radius is smaller than the equatorial radius, therefore the acceleration due to gravity is maximum at poles and minimum at the equator.
- As we move from the **equator towards the north pole**, while remaining on the surface of the earth, then the **value of g increases**. Therefore option 2 is correct.



Important Point

- If the earth is rotating, then the effect of rotation of the earth on the value of acceleration due to gravity is maximum at the equator and is minimum at the poles.
- If the earth suddenly stops rotating about its axis, then the value of g will be the same at all the places.

39. Answer: c

Explanation:

CONCEPT:

- Magnetic field and magnetic lines of force : It is the space around a magnetic pole or magnet or current-carrying wire within which its magnetic effect can be experienced is defined as a magnetic field.
- The magnetic field can be represented with the help of a set of lines or curves called magnetic lines of force or magnetic field lines.

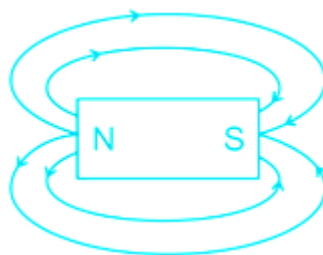

Properties of magnetic field line:

1. The magnetic field line is directed from the north pole to the south pole outside and south to the north inside the magnet.
2. Magnetic field lines are closed and continuous.

3. Magnetic field lines are more crowded near poles which shows that the strength of the magnetic field is maximum at its poles.
4. Magnetic field lines never intersect with each other.

EXPLANATION:

- The phenomenon of **production of electromotive force or voltage across** an electrical conductor in a varying magnetic field is called **magnetic induction** . Therefore option 1 is incorrect.
- From above it is clear that, the region surrounding a magnet in which its influence can be felt is called its magnetic field. Therefore option 3 is correct.
- The total number of magnetic field lines or magnetic lines of force passing through a surface area normally is called magnetic flux . Therefore option 4 is incorrect.

40. Answer: d

Explanation:

Given: Triangles PQR and BAC are similar triangles.

Concept Used: In this type of question, if two triangles are similar then their corresponding angles are congruent and corresponding sides are in proportion

Formula Used: $AB : PQ = CA : RQ$

Calculation : using the above formulae, we get

$$\Rightarrow 36 : 9 = 48 : RQ$$

$$\Rightarrow RQ = 12 \text{ cm}$$

\therefore required length of RQ = 12 cm.

41. Answer: a

Explanation:

Given:

$$4x^2 + 4x - 3 = 0$$

Calculation:

$$\Rightarrow 4x^2 + 4x - 3 = 0$$

$$\Rightarrow 4x^2 + 6x - 2x - 3 = 0$$

$$\Rightarrow 2x(2x + 3) - 1(2x + 3) = 0$$

$$\Rightarrow (2x + 3)(2x - 1) = 0$$

$$\Rightarrow x = -3/2, 1/2$$

42. Answer: c

Explanation:

CONCEPT:

Myopia (short-sightedness):

- It is a defect of the eye due to which a person can see a nearby object clearly but cannot see far away object clearly .
- In this defect, the image is formed before the retina and far point comes closer .

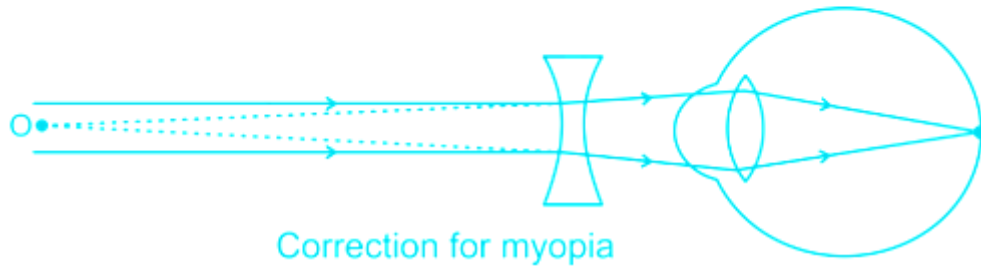
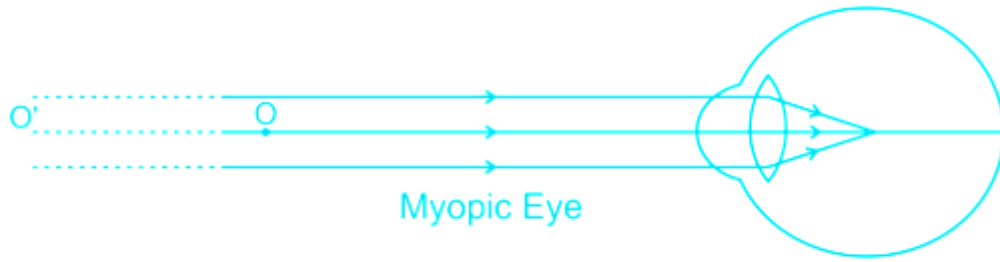

- In this defect focal length or radii of curvature of the lens is reduced or the power of the lens increases or the distance between the eye lens and retina increases i.e., the eyeball becomes too long .
- This defect can be removed by using a concave lens of suitable focal length .

EXPLANATION:

Given - Power of lens (P) = -2.5 D

- The power of a lens is its ability to bend light and it is equal to the reciprocal of the focal length of the lens in meters.
- Power (P) = $1/f$

Where f is the focal length of the lens in meters .

- Focal length of the lens is

$$\Rightarrow P = 1/f$$

$$\Rightarrow f = -100/2.5 \text{ D} = - 40 \text{ cm}$$

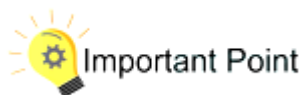

Defects of Vision	Details	Corrections
Hypermetropia or Farsightedness	The human eye can see distant objects clearly but cannot see nearby objects clearly .	Convex Lens
Presbyopia	In this defect, both near and far objects are not clearly visible . It is an old age disease and it is due to the loosing power of accommodation .	Bifocal lenses
Astigmatism	In this defect, the eye cannot see horizontal and vertical lines clearly, simultaneously . It is due to the imperfect spherical nature of the eye lens .	Cylindrical lens

43. Answer: b

Explanation:

CONCEPT :

- Force : The interaction which after applying on a body changes or try to change the state of motion or state of rest is called force.
- Force is denoted by F and the SI unit is **Newton (N)** .
- Force (F) = Mass (m) × acceleration (a)

EXPLANATION :

- Force can be written mathematically as

$$\Rightarrow F = m \times a$$

As we know, the **dimension of mass (m)** = [M]

The **dimension of acceleration (a)** = [LT⁻²]

∴ The **dimension of force (F)** is

$$\Rightarrow F = [M] \times [LT^{-2}] = [MLT^{-2}]$$

44. Answer: b

Explanation:

Given:

Diameter of sphere = 12 cm

Length of wire = 48 cm

Formula used:

$$\text{Volume of sphere} = \left(\frac{4}{3}\right)\pi \times \text{radius}^3$$

$$\text{Volume of cylinder} = \pi \times \text{radius}^2 \times \text{height}$$

Calculation:

According to question

$$\text{Volume of cylinder (wire)} = \text{volume of sphere}$$

$$\Rightarrow \pi \times \text{radius}^2 \times 48 = \left(\frac{4}{3}\right) \times \pi \times 6 \times 6 \times 6$$

$$\Rightarrow \text{radius}^2 = \frac{4 \times 6 \times 6 \times 6}{3 \times 48}$$

$$\Rightarrow \text{radius}^2 = 6$$

$$\Rightarrow \text{Radius} = \sqrt{6} \text{ cm}$$

$$\text{Diameter} = 2 \times \text{radius}$$

\therefore Diameter of cylinder (wire) = $2\sqrt{6}$ cm

45. Answer: b

Explanation:

CONCEPT :

Newton's Second Law:

- The rate of change of linear momentum of a body is directly proportional to the external force applied on the body and this change takes place always in the direction of the applied force .
- If a body of mass m moves with velocity then its linear momentum can be given by and if force is applied on a body, then

$$\therefore \vec{F} = m\vec{a}$$

Where F = Force, m = mass and a = acceleration

- If the **two equal masses are tied to each other** , then the amount of acceleration on the body is given by

$$\frac{1}{a} = \frac{1}{a_1} + \frac{1}{a_2}$$

a_1 = Acceleration of the first body, a_2 = Acceleration of the second body

CALCULATION:

Given - Acceleration of the first body, $a_1 = 6\text{m/s}^2$, Acceleration of second body , $a_2 = 3\text{m/s}^2$,

- Given that the **same amount of force is acting on both the masses** i.e., $F_1 = F_2 = F$ (let)
- According to Newton's second law, the force acting on the body is given by

$$\Rightarrow F = ma$$

Above equation can be rewritten for mass (m) as,

$$\Rightarrow m = \frac{F}{a}$$

- The mass of the first block is given by

$$\Rightarrow m_1 = \frac{F}{a_1} \quad \text{-----(1)}$$

- The mass of the second block is given by

$$\Rightarrow m_2 = \frac{F}{a_2} \quad \text{-----(2)}$$

- On adding equation 1 and equation 2 we get,

$$\Rightarrow m = m_1 + m_2$$

$$\Rightarrow \frac{F}{a} = \frac{F}{a_1} + \frac{F}{a_2}$$

$$\Rightarrow \frac{1}{a} = \frac{1}{a_1} + \frac{1}{a_2}$$

$$\Rightarrow a_{total} = \frac{a_1 a_2}{a_1 + a_2} = \frac{6 \times 3}{6 + 3} = 2m/s^2$$

- The acceleration of two blocks when tied up is, $a_{total} = 2m/s^2$

Your Personal Exams Guide

46. Answer: b

Explanation:

Concept:

surface area of the remaining solid = surface area of cube + curved surface area of hemisphere - base area of hemisphere

Formula used:

surface area of cube = $6(\text{length of edge})^2$

curved surface area of hemisphere = $2\pi r^2$

base area of hemisphere = πr^2

Calculation: using the above formulae we get,

Here diameter of sphere = 'l' cm; $r = l / 2$ cm

curved surface area of hemisphere = $2\pi(l / 2)^2$

$$\Rightarrow \pi l^2 / 2$$

base area of hemisphere = $\pi(l / 2)^2$

$$\Rightarrow \pi l^2 / 4$$

\therefore surface area of the remaining solid = $6l^2 + \pi l^2 / 2 - \pi l^2 / 4$

$$\Rightarrow l^2 / 4 \times (24 + \pi) \text{ cm}^2$$

47. Answer: c

Explanation:

Given:

$$x^2 - 2x - 15$$

Calculation:

$$x^2 - 2x - 15$$

$$\Rightarrow x^2 - 5x + 3x - 15$$

$$\Rightarrow x(x - 5) + 3(x - 5)$$

$$\Rightarrow (x - 5)(x + 3)$$

$$\Rightarrow x = 5, -3$$

48. Answer: b

Explanation:

CONCEPT :

- The powers to which fundamental quantities must be raised in order to express the given physical quantity are called its dimensions .
- A quantity without dimension will usually be a ratio of two quantities with similar dimensions and hence, will cancel out . Thus, they will have no units .

EXPLANATION :

- **Velocity:** It is defined as the **rate of change of displacement** i.e.

$$\Rightarrow \text{Velocity} = \frac{\text{Displacement}}{\text{Time}} = \frac{[L]}{[T]} = [LT^{-1}]$$

∴ Velocity is not the dimensionless quantity .

- **Angle:** It is defined as the ratio of the length of arc to the radius, i.e.,

$$\text{Angle } (\theta) = \frac{\text{length of arc } (l)}{\text{radius } (r)}$$

$$\Rightarrow \theta = \frac{[M^0 LT^0]}{[M^0 LT^0]} = 1$$

∴ An angle is a dimensionless quantity

- Mass is a not dimensionless quantity . as the **dimension of mass** is **[M]** .
- The **area** is a not dimensionless quantity . as the dimension of the area is **[L²]** .



Important Point

Quantity	Unit	Dimension
Pressure	Pascal	$[ML^{-1}T^{-2}]$
Stress	Pascal	$[ML^{-1}T^{-2}]$
Young Modulus	Pascal	$[ML^{-1}T^{-2}]$
Speed	m/s	$[LT^{-1}]$
Momentum	kg·m/s	$[MLT^{-1}]$
Potential difference	Volt	$[ML^2T^{-3}A^{-1}]$
Torque	Newton meter	$[ML^2T^{-2}]$
Work	Joule	$[ML^2T^{-2}]$

Your Personal Exams Guide

49. Answer: a

Explanation:

Given:

Base = 10 cm

Other two sides = 6 cm each

Concept:

Isosceles triangle has two sides of equal length.

Perpendicular on non-equal side from the opposite bisect the side in two equal part.

Formula used:

Area of triangle = $(1 / 2) \times \text{base} \times \text{height}$

Hypotenuse $^2 = \text{perpendicular}^2 + \text{base}^2$

prepp

Your Personal Exams Guide

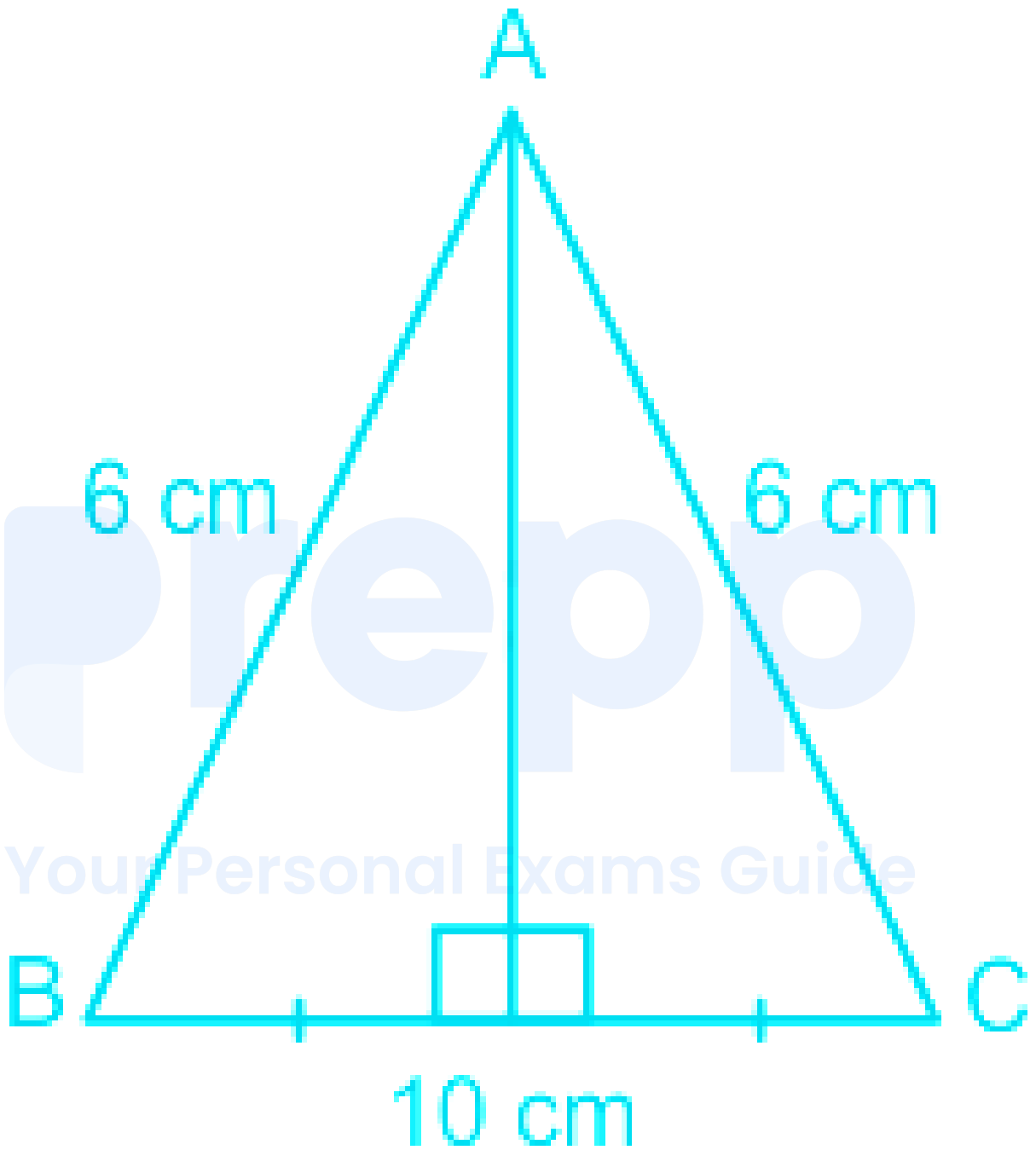

Height of triangle

$$\text{Height}^2 = \text{Hypotenuse}^2 - \text{base}^2$$

$$\Rightarrow \text{Height}^2 = 6^2 - 5^2$$

$$\Rightarrow \text{Height}^2 = 11$$

$$\Rightarrow \text{Height} = \sqrt{11} \text{ cm}$$

Area of triangle = $(1 / 2) \times \text{base} \times \text{height}$

$$\Rightarrow (1 / 2) \times 10 \times \sqrt{11}$$

$$\Rightarrow 5\sqrt{11} \text{ cm}^2$$

\therefore required area of $\Delta = 5\sqrt{11} \text{ cm}^2$

50. Answer: a

Explanation:

CONCEPT :

Newton's First law :

- A body continues to be in its state of rest or of uniform motion along a straight line unless it is acted upon by some external force to change the state .
- If no net force acts on a body , then the velocity of the body cannot change i.e. the body cannot accelerate.
- Newton's first law defines inertia and is rightly called the law of inertia .

Newton's Second Law:

- The rate of change of linear momentum of a body is directly proportional to the external force applied on the body and this change takes place always in the direction of the applied force .
- If a body of mass m moves with velocity then its linear momentum can be given by and if force is applied on a body, then

$$\therefore \vec{F} = m\vec{a}$$

Where F = Force, m = mass and a = acceleration

CALCULATION:

Given - F = force acting on the mass, m = mass of the body, and initial velocity (U) = 0 m/s

- The **acceleration of the particle** is given by

$$\Rightarrow a = \frac{F}{m}$$

- The equation of motion of the particle after moving a certain displacement is given by

$$\Rightarrow V^2 - U^2 = 2as$$

Substituting the values of 'a' in the equation, we get

$$\Rightarrow V^2 = 2\left(\frac{F}{m}\right)S$$

$$\Rightarrow V = \sqrt{2\left(\frac{F}{m}\right)S}$$

From the above equation 3 it is clear that

$$\Rightarrow V \propto \frac{1}{\sqrt{m}}$$

- Hence option 1 is the answer.

51. Answer: d

Explanation:

Given:

$(2, 0, 2)$ and $(-2, 2, -2)$

Formula:

Distance between two points = $\sqrt{\{(x_1 - x_2)^2 + (y_1 - y_2)^2 + (z_1 - z_2)^2\}}$

Calculation:

$$\Rightarrow \sqrt{\{(2 + 2)^2 + (0 - 2)^2 + (2 + 2)^2\}}$$

$$\Rightarrow \sqrt{\{16 + 4 + 16\}}$$

$$\Rightarrow \sqrt{36}$$

$$\Rightarrow 6$$

\therefore required distance = 6 unit

52. Answer: a

Explanation:

Concept:

Principle of homogeneity of dimensions:

- According to this principle, a physical equation will be dimensionally correct if the dimensions of all the terms occurring on both sides of the equation are the same.
- This principle is based on the fact that only the physical quantities of the same kind can be added, subtracted, or compared.
- Thus, velocity can be added to velocity but not to force.

Explanation:

Given:

$$s = at + bt^2$$

From the principle of dimensional homogeneity, the left-hand side of the equation is dimensionally equal to the right-hand side of the equation. So, the dimension of (s), (at) and (bt²) is the same.

The dimension formula of distance (s) = [L]

For the first term:

$$\therefore [L] = [a] [T]$$

$$\Rightarrow [a] = \frac{[L]}{[T]} = [LT^{-1}]$$

For the second term:

$$\Rightarrow [L] = [b] [T^2]$$

$$\Rightarrow [b] = \frac{[L]}{[T^2]} = [LT^{-2}]$$

The dimensional formula of 'b' is $[M^0 L^1 T^{-2}]$.

53. Answer: b

Explanation:

CONCEPT:

Distance :

- The measurement of how much any object moved is called distance .
- It is a scalar quantity .

Displacement :

- The minimum distance between two points is called displacement of the object.
- It is a vector quantity .

CALCULATION:

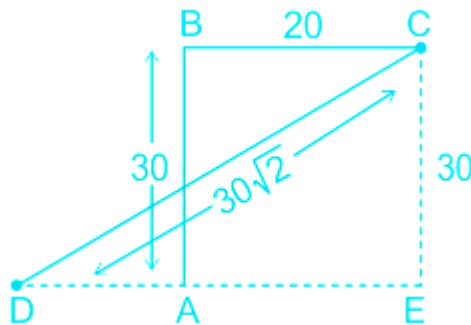

Given - Distance moved to North = 30 m, Distance moved to east = 20 m, and The distance moved in S-W Direction $30\sqrt{2}m$

In $\triangle DCE$,

$$\Rightarrow CD^2 = ED^2 + CE^2$$

$$\Rightarrow ED^2 = (30\sqrt{2})^2 - (30)^2$$

$$\Rightarrow ED^2 = 1800 - 900 = 900$$

$$\Rightarrow ED = 30 \text{ m}$$

\therefore The displacement of the person from the origin will be

$$\Rightarrow AD = DE - AE = 30 - 20 = 10 \text{ m}$$

- The displacement of the person from the origin is 10 m along the west . Hence option 2 is correct.

★ Important Points

- The magnitude of displacement is equal to the minimum possible distance between two positions . So distance \geq Displacement .
- For a moving particle, distance can never be negative or zero while displacement can be (Zero displacement means that body after motion has come back to initial position). i.e., Distance > 0 but Displacement $> =$ or < 0 .
- For motion between two points displacement is single-valued while distance depends on the actual path and so can have many values.
- For a moving particle, distance can never decrease with time while displacement can .

- A decrease in displacement with time means the body is moving towards the initial position .

54. Answer: a

Explanation:

CONCEPT:

- **Joule's law** establishes the relationship between the **amount of heat produced** when a current is passed through the circuit.
- **Joule's law gives** the mathematical idea the **rate at which electric current is converted into heat.**
- Joule's law is given by

$$H = I^2 R t$$

Where I = Amount of current, R = Resistance, t = time, H = Amount of heat produced

- **Joule is the unit of heat.**

CALCULATION:

Given - R = 20 Ω , I = 5 A, and t = 30 s

- The amount of heat generated is given by

$$\Rightarrow H = I^2 R t$$

$$\Rightarrow H = 5^2 \times 20 \times 30 = 25 \times 600 = 15000 = 1.5 \times 10^4 \text{ J}$$

55. Answer: a

Explanation:

CONCEPT :

Newton's Second Law:

- The rate of change of linear momentum of a body is directly proportional to the external force applied on the body and this change takes place always in the direction of the applied force .
- If a body of mass m moves with velocity then its linear momentum can be given by and if force is applied on a body, then

$$\therefore \vec{F} = m\vec{a}$$

Where F = Force, m = mass and a = acceleration

- **Linear mass density** is defined as the **mass per unit length of a substance** .
 - Kg/m is the unit of linear mass density

CALCULATION:

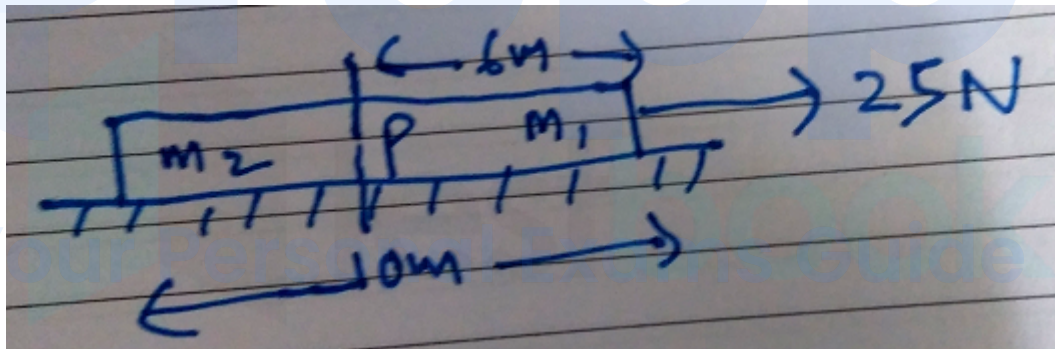

Given - Length of the rope (L) = 10 m, linear density (λ) = 0.5kg/m, force (F) = 25N, $L_1 = 6$ m, $L_2 = 4$ m

- The mass of the rope is given by

$$\text{Mass of the rope (m)} = \lambda \times L = 0.5 \times 10 = 5 \text{ Kg}$$

- The acceleration of the rope is given by

$$\Rightarrow F = ma$$

$$\Rightarrow a = \frac{F}{m} = \frac{25}{5} = 5 \text{ m/s}^2$$

- The rope can be treated as two masses, m_1 = The mass at 6 m away from point of force application, and m_2 = The mass other than m_1 in the total rope.

$$\Rightarrow m_1 = \lambda \times L_1 = 0.5 \times 6 = 3 \text{ Kg}$$

$$\Rightarrow m_2 = \lambda \times L_2 = 0.5 \times 4 = 2 \text{ Kg}$$

- The mass m_2 will be pulled by a force given by m_1
- Since the entire rope is moving with $a = 5 \text{ m/s}^2$, then the acceleration of m_2 also is 5 m/s^2
- Let f be the force acting on that part of the rope, is given by

$$\Rightarrow f = m_2 a$$

$$\Rightarrow f = 2 \times 5 = 10 \text{ N}$$

- The force acting on the rope is 10 N.

56. Answer: a

Explanation:

CONCEPT:

Resistance (R):

- The resistance offered to the flow of current is known as the resistance .
- SI unit of resistance is the ohm (Ω).
- Mathematically resistance can be written as

$$R = \frac{\rho l}{A}$$

Where R = resistance, l = length, A = area of cross-section and ρ = resistivity

CALCULATION:

Given - Length (L) = 1 m, Area of cross-section (A) = 1 m², and Resistivity (ρ) = $2 \times 10^6 \Omega\text{-m}$

- The relationship between the resistance of a conductor and resistivity is given by

$$\Rightarrow R = \frac{\rho l}{A}$$

$$\Rightarrow R = \frac{2 \times 10^6 \times 1}{1} = 2 \times 10^6 \Omega$$

57. Answer: c

Explanation:

CONCEPT :

- Centripetal force is that force which is required to move a body in a circular path with uniform speed.
- The force acts on the body along the radius and towards the centre .
- Formulae for centripetal force is

$$F = \frac{mv^2}{r^2}$$

Where F = Centripetal force, m = mass of the body, v = velocity of the body and r = radius

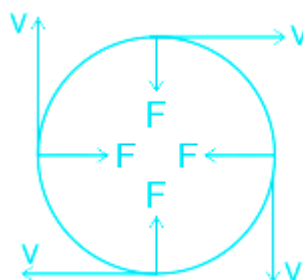

- The Law of Conservation of Energy states that the total energy of an isolated system remains conserved (constant), that is, it can neither be created nor be destroyed but it can be transformed from one form to another.

- One of the most common examples of the Law of Conservation of Energy is: an object falling freely under gravity as shown below

CALCULATION:

- Let D be the diameter of the sphere, then the radius is given by

$$\Rightarrow r = \frac{D}{2}$$

- Since the **particle is sliding down under the influence of gravity**, therefore the centripetal force must be equal to the gravitational pull

$$\Rightarrow \frac{mV^2}{r} = mg$$

$$\Rightarrow V = \sqrt{gr}$$

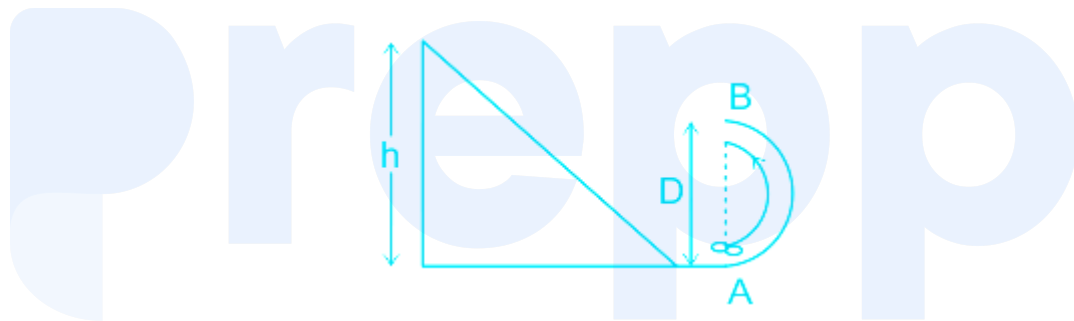

- According to the law of conservation of energy, the **total energy of an isolated system remains conserved (constant)** i.e., the total energy before and after transformation will be the same .
- When the body is at the top of the track, then it will have only **potential energy** i.e., the **initial energy of the body with the reference of B** will be

$$\Rightarrow E_1 = mg(H-D)$$

- We will use the work energy theorem for the motion from the top of the hill and point B.

\Rightarrow Work done by gravitational force = Change if KE of the system

$$\Rightarrow mg(H-D) = \frac{1}{2}mv^2 - 0 \quad \dots(1)$$

Where v is the velocity at point B.

- Now, for the completion of the loop successfully, the normal reaction because of the track at its topmost point B will be always greater than or equal to zero.
- For point B,
- N will act downward and mg will also act downward but centrifugal force will act upward at point B.

So,

$$N + mg = \frac{mv^2}{D/2}$$

$$\Rightarrow N = \frac{mv^2}{D/2} - mg \geq 0 \quad \dots(2)$$

Where v is the velocity at point B.

Using 1 and 2,

$$\frac{mv^2}{D/2} - mg \geq 0$$

$$\Rightarrow mv^2 \geq mgD/2$$

$$\Rightarrow 2mg(H - D) \geq mgD/2$$

$$\Rightarrow H \geq \frac{5D}{4}$$

prepp
Your Personal Exams Guide

58. Answer: a

Explanation:

CONCEPT :

Acceleration due to gravity

- The force of attraction exerted by the earth on a body is called gravitational pull or gravity .
- We know that when a force acts on a body, it produces acceleration. Therefore, a body under the effect of gravitational pull must accelerate.

- The acceleration produced in the motion of a body under the effect of gravity is called acceleration due to gravity, it is denoted by g
- If g is the acceleration due to gravity, then

$$g = \frac{GM}{r^2}$$

Where G = gravitational constant, M = mass of the earth and R = radius of the earth

- The acceleration due to gravity at height h above from the surface is given by

$$g = \frac{GM}{(R+h)^2}$$

Where h = height h from the surface and R = radius of the earth

- **Weight** of a body is the amount of work done by the gravitational force on a body, is given by

$$W = mg$$

Where g = Acceleration due to gravity, m = mass of the body

CALCULATION:

Given - Weight of a man on the surface of the earth = W ,

- The value **acceleration** due to gravity at the surface of the earth is given by

$$\Rightarrow g = \frac{GM}{R^2}$$

- The weight of a man at the surface of the earth is given by

$$\Rightarrow W = mg$$

Substituting the value of g in the above equation, we get

$$\Rightarrow W = \frac{mGM}{R^2}$$

- The variation in g with respect to the height is given by

$$\Rightarrow g' = \frac{g}{(R+h)^2}$$

- Substituting the value $h = 2R$ in above equation 4, we get

$$\Rightarrow g' = \frac{g}{(R+2R)^2} = \frac{g}{9R^2}$$

- The weight of a man at height $2R$, is given by

$$\Rightarrow W' = mg' = \frac{mg}{9R^2}$$

$$\Rightarrow W' = \frac{1}{9} \times \frac{mg}{R^2} = \frac{W}{9}$$

- The weight of man at the height $2R$ is $\frac{W}{9}$

59. Answer: d

Explanation:

Concept:

If two pairs of corresponding angles in a pair of triangles are congruent, then the triangles are similar. We know this because if two angle pairs are the same, then the third pair must also be equal. When the three angle pairs are all equal, the three pairs of sides must also be in proportion.

Calculation:

According to concept

$$\angle K = \angle B$$

$$\therefore \angle B = 30^\circ$$

60. Answer: c

Explanation:

Given:

$$x + 2y = 6$$

$$x - 2y = 16$$

Calculation:

$$\Rightarrow x + 2y = 6 \quad \text{----- (i)}$$

$$\Rightarrow x - 2y = 16 \quad \text{----- (ii)}$$

Solving both the equations

$$\Rightarrow 2x = 22$$

$$\Rightarrow x = 11$$

Now putting the value of x in equation i

$$\Rightarrow 11 + 2y = 6$$

$$\Rightarrow 2y = -5$$

$$\Rightarrow y = -5 / 2$$

$$\therefore x = 11, y = -5 / 2$$

Your Personal Exams Guide

61. **Answer: d**

Explanation:

Given:

$$AB = 3 \text{ cm}$$

$$BC = 5 \text{ cm}$$

$$\text{Angle B} = 60^\circ$$

Formula used:

$$\text{Cosine rule} = c^2 = a^2 + b^2 - 2ab \cos(C)$$

Calculation:

$$AC^2 = AB^2 + BC^2 - 2(AB) \times (BC) \times \cos B$$

$$\Rightarrow AC^2 = 9 + 25 - 2 \times 15 \times \cos 60^\circ$$

$$\Rightarrow AC^2 = 34 - 30 \times \frac{1}{2}$$

$$\Rightarrow AC^2 = 19$$

$$\Rightarrow AC = \sqrt{19} \text{ cm}$$

62. Answer: b

Explanation:

CONCEPT:

Convex mirror:

- The mirror in which the rays diverges after falling on it is known as the **convex mirror**.
 - Convex mirrors are also known as a diverging mirror.
 - The focal length of a convex mirror is positive according to the sign convention.
- Mirror Formula: The following formula is known as the mirror formula:

$$\frac{1}{f} = \frac{1}{u} + \frac{1}{v}$$

where f is focal length v is the distance of the image from the mirror, and u is the distance of the object from the mirror.

Linear magnification (m):

- It is defined as the ratio of the height of the image (h_i) to the height of the object (h_o).

$$m = \frac{h_i}{h_o}$$

- The ratio of image distance to the object distance is called linear magnification .

$$m = \frac{\text{image distance } (v)}{\text{object distance } (u)} = -\frac{v}{u}$$

- A **positive value of magnification** means a **virtual and erect image** .
- A **negative value of magnification** means a **real and inverted image** .

CALCULATION:

- Given - Object distance (U) = -10 cm and Focal length (f) = 15 cm
- The mirror formula is given by

$$\Rightarrow \frac{1}{f} = \frac{1}{v} + \frac{1}{u}$$

$$\Rightarrow \frac{1}{15} = \frac{1}{v} - \frac{1}{10}$$

$$\Rightarrow \frac{1}{v} = \frac{1}{10} + \frac{1}{15}$$

$$\Rightarrow v = \frac{25}{150} = 6\text{cm}$$

- The magnification of a mirror is

$$m = -\frac{v}{u}$$

$$\Rightarrow m = -\frac{v}{u} = -\frac{6\text{cm}}{-10\text{cm}} = +0.6$$

- The magnification of the object is + 0.6.

63. **Answer: b**

Explanation:

CONCEPT:

- Power of Accommodation of eye is the ability of the eye to observe distinctly the objects situated at widely different distances from the eye, on account of change in focal length of eye lens by the action of ciliary muscles holding the lens.
- The maximum power of accommodation of the eye for a person having normal vision ($d = 25 \text{ cm}$) is

$$P = \frac{100}{f} = \frac{100}{d} = \frac{100}{25} = 4 \text{ dioptre}$$

EXPLANATION:

- When an object is too close to the eye, the lens cannot curve enough to focus the image on the retina. Therefore, the image is blurred.
- The point at closest distance, at which an object can be seen clearly by the eye is called near Point (N) of the eye.
- The distance of the near point of a normal eye is called the least distance of distinct vision. It is represented by d .
- For a normal eye, the value of the least distance of distinct vision is $d = 25 \text{ cm}$.
- The far point of the human eye is defined as the maximum distance to which the eye can see the object clearly.
- The far point of human with normal vision is infinity.

Your Personal Exams Guide

64. Answer: d

Explanation:

CONCEPT :

- Concave mirror: If the inner surface of the spherical mirror is the reflecting surface, then it is called a concave mirror. It is also called a focusing mirror/converging mirror.
 - The size of the image produced by these mirrors can be larger or smaller than the object, depending upon the distance of the object from the mirror.

- The concave mirror can form both real as well as virtual images of any object .
- Mirror formula: The expression which shows the relation between object distance (u) , image distance (v) , and focal length (f) is called mirror formula .

$$\frac{1}{v} + \frac{1}{u} = \frac{1}{f}$$

Linear magnification (m):

- It is defined as the ratio of the height of the image (h_i) to the height of the object (h_o) .

$$m = \frac{h_i}{h_o}$$

- The ratio of image distance to the object distance is called linear magnification .

$$m = \frac{\text{image distance (v)}}{\text{object distance (u)}} = -\frac{v}{u}$$

- A **positive value of magnification** means **virtual and erect image** .
- A **negative value of magnification** means a **real and inverted image** .

EXPLANATION:

- According to the question, the **magnification produced by the mirror is +3** which means the image formed by the concave mirror is **virtual, erect, and enlarged** .

65. Answer: c

Explanation:

Given:

7, 19, 31, 43,

Calculation:

$$\Rightarrow 19 - 7 = 12$$

$$\Rightarrow 31 - 19 = 12$$

$$\Rightarrow 43 - 31 = 12$$

\therefore Common difference = 12

66. Answer: a

Explanation:

Given:

A(2, -3) and B(-2, 1)

Formula used:

Equidistant point $P(x, y) = \left\{ \frac{x_1 + x_2}{2}, \frac{y_1 + y_2}{2} \right\}$

Calculation:

$$\Rightarrow \left\{ \frac{2 - 2}{2}, \frac{-3 + 1}{2} \right\}$$

$$\Rightarrow 0, -1$$

67. Answer: c

Explanation:

Concept:

A rational number is a number that can be expressed as the quotient or fraction $\frac{p}{q}$ of two integers, a numerator p , and a non-zero denominator q . Since q may be equal to 1, every integer is a rational number.

A real number that is not rational is called irrational. Irrational numbers include $\sqrt{2}$, π , e , and φ . The decimal expansion of an irrational number continues without

repeating. Since the set of rational numbers is countable, and the set of real numbers is uncountable, almost all real numbers are irrational.

Calculation:

\therefore In all the given options only 2 is satisfying the condition of a rational number.

\therefore Option 3 is the right answer

68. Answer: b

Explanation:

According to question:

Disco beam cover $360^\circ = 2\pi$ in 20 min

So, in 2 min it will cover $\pi / 5$ or (36°)

\Rightarrow Maximum coverage = 20 m

i.e. radius = 20 m

Length of arc = $20 \times \pi / 5 = 4\pi$ m

\therefore required distance covered = 4π m

69. Answer: b

Explanation:

Area of parallelogram = (length in x-axis) \times (length in y-axis)

Area of parallelogram = $(4 \times 7) = 28$ sq.cm.

70. Answer: c

Explanation:

CONCEPT :

Sound:

- A sound is a form of energy that produces a sensation of hearing in our ears .
- It is a kind of disturbance that travels through a medium due to repeated vibrations of the particles of the medium about their mean positions .
- The disturbance being handed over from one particle to the next .

Light:

- Light is a form of electromagnetic radiation that can be detected by the human eye .
- When light falls on an object , some part of the light is reflected on our eyes and we are able to see.

EXPLANATION :

- Sound waves are longitudinal waves and light waves are transverse waves .
- As we know sound waves are longitudinal waves and travel through compression and rarefactions in the medium on the other hand light waves are transverse in nature and do not require medium to travel . Therefore option 3 is incorrect.
- As we know that, the sound wave and lightwave travels with different velocity and have a different frequency , therefore the wavelength ($\lambda = v/f$) is different for both .
- Both sound and light waves follow the law of reflection i.e. the angle of incidence is equal to the angle of reflection .

71. Answer: a

Explanation:

Given:

Equation: $(6 + 3i) + (2 + 5i)$

Concept:

Real part is added with real part and imaginary part is added with imaginary part

Calculation:

$$(6 + 3i) + (2 + 5i)$$

$$\Rightarrow 6 + 3i + 2 + 5i$$

$$\Rightarrow 8 + 8i$$

\therefore required value = $8 + 8i$

72. Answer: a

Explanation:

CONCEPT :

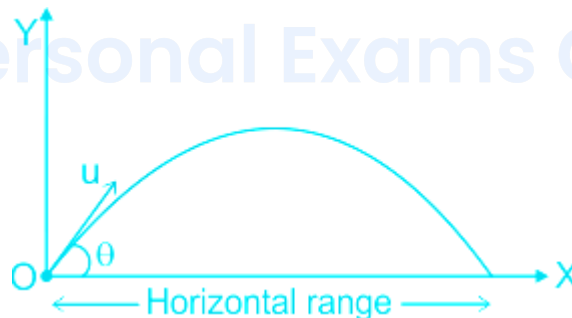

- Horizontal range : It is the horizontal distance travelled by a body during the time of flight .
- The mathematical expression of the horizontal range is:

$$R = \frac{u^2 \sin 2\theta}{g}$$

Where u = initial velocity and g = acceleration due to gravity

- Maximum height : It is the maximum height from the point of projection, a projectile can reach
- The mathematical expression of the horizontal range is:

$$H = \frac{u^2 \sin^2 \theta}{2g}$$

CALCULATION :

- The horizontal range of a projectile is given by

$$\Rightarrow R = \frac{u^2 \sin 2\theta}{g}$$

- From the above equation it is clear that

$$\Rightarrow R \propto \sin 2\theta$$

- From the above equation, it is clear that 2θ will increase till the value becomes one

$$\Rightarrow \sin 2\theta = 1$$

$$\Rightarrow \theta = \sin^{-1}\left(\frac{1}{2}\right)$$

$$\Rightarrow \theta = 45^\circ$$

- The horizontal range of the projectile increases up to 45° and then decreases afterward.

73. Answer: c

Explanation:

Given:

$$5^{\text{th}} = 52$$

$$11^{\text{th}} = 184$$

Formula used:

$$a_n = a_1 + (n - 1) \times d$$

$$a_n = n^{\text{th}} \text{ number}$$

$$a_1 = 1^{\text{st}} \text{ number in series}$$

d = difference in number

Calculation:

According to question:

$$\Rightarrow a_1 + (5 - 1) d = 52$$

$$\Rightarrow a_1 + (17 - 1) d = 184$$

$$\Rightarrow a_1 + 4d = 52 \quad \text{---(i)}$$

$$\Rightarrow a_1 + 16d = 184 \quad \text{---(ii)}$$

On equating both the equation we get

$$\Rightarrow d = 11$$

\therefore required common difference = 11

74. Answer: c

Explanation:

Given:

Diameter of bigger plate = 3.5 cm

Diameter of smaller plate = 2.5 cm

Formula used:

Surface area of plate = $\pi \times \text{radius}^2 = \pi \times \text{diameter}^2 / 4$

Calculation:

$$\Rightarrow \pi \{(3.5)^2 - (2.5)^2\} / 4$$

$$\Rightarrow \pi \{6\} / 4$$

$$\Rightarrow 1.5 \pi$$

75. Answer: b

Explanation:

CONCEPT :

- Acceleration: The time rate of change of velocity of an object is called the acceleration of the object .

$$a = \frac{\Delta v}{\Delta t}$$

Where Δv = change in velocity and Δt = change in time

- It is a vector quantity .
- Its direction is the same as that of change in velocity (Not of the velocity).

EXPLANATION :

- Average acceleration : For an object moving with variable velocity , the average acceleration is defined as the ratio of the total change in velocity of the object to the total time interval taken .

$$\Rightarrow \text{Average velocity} = \frac{\text{change in velocity}}{\text{time taken}}$$

- Suppose v_1 and v_2 , are the velocities of an object at times t_1 and t_2 , respectively, then its average acceleration is

$$a_{av} = \frac{v_2 - v_1}{t_2 - t_1} = \frac{\Delta v}{\Delta t}$$

Where v_2 = velocity of the object at t_2 and v_1 = velocity of the object at t_1

prepp

Your Personal Exams Guide