

Prepp

Your Personal Exams Guide



NDA



CDS



SSC CGL



CBSE UGC NET



IAS



SSC CHSL



CTET



MPSC



AFCAT



CSIR UDC NET



IBPS PO



UP POLICE



SSC MTS



SBI PO



BSPSC



UP TET



IBPS RRB



IBPS CLERK



IES



UPSC CAPF



SSC Stenogr..



RRB NTPC



SSC GD



RBI GRADE B



RBI Assistant



DSSSB

RRB ALP 2019 (Electronics Mechanic) Prev. Year Paper (21-Jan-2019) (Shift 3)

Total Time: 2 Hour : 30 Minute

Total Marks: 175

Instructions

Sl No.	Section Name	No. of Question	Maximum Marks	Negative Marks	Positive Marks	Sectional Timing
1	Part A	100	100	0.33	1	90 Min
2	Part B	75	75	0.33	1	60 Min

- 1.) A total of 150 minutes is allotted for the examination.
- 2.) The server will set your clock for you. In the top right corner of your screen, a countdown timer will display the remaining time for you to complete the exam. Once the timer reaches zero, the examination will end automatically. The paper need not be submitted when your timer reaches zero.
- 3.) There will, however, be sectional timing for this exam. You will have to complete each section within the specified time limit. Before moving on to the next section, you must complete the current one within the time limits.

Part A

1. The least number consisting of five digits and that is divisible by 97 is x . (+1, -0.33)
What is the sum of digits of x ?

- a. 15
- b. 13
- c. 16
- d. 17

2. Laho dance belongs to the state of _____ in India. (+1, -0.33)

- a. Meghalaya
- b. Rajasthan
- c. Orissa
- d. Andhra Pradesh

3. Which of the following Venn diagrams best represents the relationship between women, mother, and doctor? (+1, -0.33)





4. A block of wood floats in water with 30% of its volume above water (density 10^3 kg/m^3). The density of wood (in kg/m^3) is: (+1, -0.33)

- a. 6×10^3
- b. 5×10^2
- c. 7×10^2
- d. 3×10^2

5. Select the number that is related to the third number in the same way as the second number is related to the first number (+1, -0.33)

$2/5 : 0.4 :: 1/200 : ?$

- a. 0.005
- b. 0.05
- c. 0.2
- d. 0.002

6. What is the distance between the points $(-2, 4)$ and $(4, 4)$? (+1, -0.33)

- a. 8 units
 - b. 4 units
 - c. 2 units
 - d. 6 units
-

7. A/An _____ is the software that manages all of a computer's processes and allows programs and applications to run. (+1, -0.33)

- a. spam
 - b. malware
 - c. modem
 - d. operating system
-

8. A statement/group of statements is given followed by some conclusion. (+1, -0.33)
Choose the conclusion that logically follows from the given statements.

Statement: All hardworking worker in the factory have been promoted in the last five year:

- a. Some worker who were promoted in the last five year are hardworking
 - b. There are no worker in the factory who are not hardworking
 - c. Hardworking is the only criteria for promotion
 - d. After promotion, some worker stopped working hard
-

9. A sum of money invested at a compound interest amounts to 800 in 2 year and 840 in 3 year. The rate of interest is: (+1, -0.33)

- a. 5%
- b. 7%
- c. 6%
- d. 4%

10. Choose the figure that is different from the rest. (+1, -0.33)

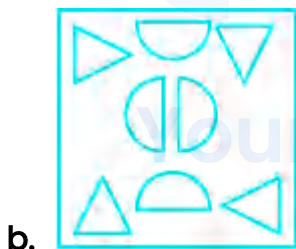



d.

11. The resulting value of $0.5 \div 12.5 + 0.25 \times 0.05 - 0.0125$ is: (+1, -0.33)

- a. 0.04
- b. 0.5
- c. 0.4
- d. 0.05

12. Bio-gas is an excellent fuel as it contains up to _____% methane. (+1, -0.33)

- a. 85
- b. 70
- c. 50
- d. 80

13. Identify the material having the lowest coefficient of linear expansion. (+1, -0.33)

- a. Brass
- b. Iron
- c. Copper

d. Lead

14. In a certain code language, '+' represents 'x', '-' represents '+', 'x' represents '÷' and '÷' represents '-', calculate the answer of the following equation. (+1, -0.33)

$$8 + 3 \times 4 - 2 = ?$$

- a. 12
 - b. 6
 - c. 10
 - d. 8
-
15. Who invented the World Wide Web? (+1, -0.33)
- a. Tim Berner-Lee
 - b. Robert E. Kahn
 - c. Vint Cerf
 - d. Antonio Meucci
-

16. Which of the following organisations prepares a Red List of Threatened Species? (+1, -0.33)
- a. RPPO
 - b. OIE
 - c. WWF

d. IUCN

17. Select the word that is related to the third word in the same way as the second word is related to the first word. (+1, -0.33)

Walnut : shell :: Banana : ?

- a. Peel
 - b. Green
 - c. Fruit
 - d. Ripe
-

18. The work to be done to increase the speed of a 0.5 kg ball from 4 m/s to 8 m/s is: (+1, -0.33)

- a. 8 J
 - b. 12 J
 - c. 16 J
 - d. 4 J
-

19. Where is the "title block" usually made? (+1, -0.33)

- a. on the upper right hand corner of the drawing sheet
- b. lower right corner of the drawing sheet
- c. on the upper left corner of the drawing sheet

d. center on the drawing sheet

20. The construction of the "Sanchi Stupa" was commissioned by which Mauryan Emperor? (+1, -0.33)

- a. Chandragupta Maurya
 - b. Bindusara
 - c. Ashoka
 - d. Kautilya
-

21. A cylindrical wire of length L and radius r has a resistance R . The resistance of another wire of the same material but of half its length and twice its radius is given by: (+1, -0.33)

- a. R
 - b. $R/2$
 - c. $R/4$
 - d. $R/8$
-

22. The weight of an object on the Earth is 150 N. Its weight on moon will be: (+1, -0.33)

- a. 75 N
 - b. 50 N
 - c. 150 N
 - d. 25 N
-

23. An object starts from rest at $x = 0$ m and $t = 0$ s. It moves with a constant acceleration of 3 m/s^2 along x axis. What is its average velocity between time duration of 2 s and 4 s? (+1, -0.33)
- a. 3 m/s
 - b. 6 m/s
 - c. 9 m/s
 - d. 12 m/s
-

24. The sum of a number and 16 times its reciprocal is 10. The number is: (+1, -0.33)
- a. 5
 - b. 6
 - c. 8
 - d. 7
-

25. A boy weighing 50 kg runs up a staircase of 40 steps, each of 16 height cm, in 10 s. Calculate his power. (Take $g = 10 \text{ m/s}^2$) (+1, -0.33)
- a. 480 W
 - b. 320 W
 - c. 120 W
 - d. 80 W
-

26. Pipes P and Q fill a cistern in 12 minutes when operated together, Q and R fill it in 20 minutes when operated together and P and R fill it in 15 minutes when operated together. In how many minutes can all 3 pipes fill the cistern if operated together? (+1, -0.33)
- a. 10 minutes
 - b. 2 minutes
 - c. 4 minutes
 - d. 3 minutes

27. Two resistors, each of 20 ohms, are connected in parallel and this combination is connected across a 40 V supply voltage. (+1, -0.33)
- Find the resistance in the circuit.
- a. 40 ohm
 - b. 10 ohm
 - c. 25 ohm
 - d. 20 ohm

28. If a person goes from his house to office walking at 80% of his usual speed, then he is late by 18 minutes to reach the office. What is the usual time taken by him to cover that same distance with his usual speed? (+1, -0.33)
- a. 78 minutes
 - b. 72 minutes
 - c. 75 minutes

d. 70 minutes

29. What is the minimum number of lines required to make the given image? (+1, -0.33)

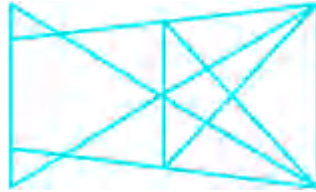

a. 11

b. 10

c. 9

d. 12

30. In the first angle projection: (+1, -0.33)

a. Object lies between observer and plane of projection

b. Object lies in the third quadrant

c. The plane of the projection lies between the object and the observer

d. Object lies in the fourth quadrant

31. At what price should a computer be sold so as to get a profit of 25% when its cost price is Rs. 18000? (+1, -0.33)

a. Rs. 20500

b. Rs. 21000

- c. Rs. 23000
 - d. Rs. 22500
-

32. A series is given, with one term missing. Choose the correct alternative from the given ones that will complete the series. (+1, -0.33)

TTTTTO, TTTTOT, TTTTOTT, TTTOTT

- a. TTTOTTTT
 - b. TTTOTTTO
 - c. TTOTT
 - d. TTOTTTT
-

33. What is the power dissipated in a 5-ohm resistor carrying 2 A current? (+1, -0.33)

- a. 10 W
 - b. 0.6 W
 - c. 2.5 W
 - d. 20 W
-

34. M, N, O and P are sitting around a round table? M does not want to sit next to P. N is to the right of P. Which statement of the below is false? (+1, -0.33)

- a. O is to the right of P
- b. M is facing P

- c. M is to the right of N
 - d. O is facing N
-

35. A black surface absorbs _____ as compared to a white surface, (+1, -0.33)
under identical conditions.

- a. same heat
 - b. negligible heat
 - c. more heat
 - d. lesser heat
-

36. The thanksgiving festival of Pongal is primarily celebrated in which state of India? (+1, -0.33)

- a. Tamilnadu
 - b. Rajasthan
 - c. Maharashtra
 - d. Uttar Pradesh
-

37. The number 800 is divided in 2 parts such that one part is $\frac{9}{7}$ times the other. The larger part is: (+1, -0.33)

- a. 480
- b. 500
- c. 450

d. 510

38. The idea of a Constituent Assembly was given by: (+1, -0.33)

- a. Dr. Rajendra Prasad
 - b. Maulana Abul Kalam Azad
 - c. M.N Roy
 - d. B.R. Ambedkar
-

39. A jogger jogs 1 km East, then turn North and jogs 4 km, then turns West (+1, -0.33)
and jogs 6 km, then turns to his left and jogs 4 km. Where is he now with
reference to his starting position?

- a. 5 km West
 - b. 7 km West
 - c. 7 km East
 - d. 5 km East
-

40. What is the HCF of 275 and 308? (+1, -0.33)

- a. 17
 - b. 19
 - c. 15
 - d. 11
-

41. What will be the distance covered by a bus moving with a speed of 72 km/h in 5 seconds? (+1, -0.33)
- a. 50 m
 - b. 200 m
 - c. 100 m
 - d. 400 m
-

42. Two resistors, one of $10\ \Omega$ and the other of $15\ \Omega$, are connected in parallel. This combination is connected in series with a $24\ \Omega$ resistor and a 12 V battery. The current in the $15\ \Omega$ resistor is: (+1, -0.33)
- a. 0.40 A
 - b. 0.24 A
 - c. 0.12 A
 - d. 0.16 A
-

43. Which of the following quantities does not have dimensions? (+1, -0.33)
- a. Frequency
 - b. Volume
 - c. Relative permeability
 - d. Force
-

44. In the question, two statements are given, followed by two conclusions, I and II. You have to consider the statements to be true even if they seem to be at variance with commonly known facts. You have to decide which of the given conclusions, if any, follow(s) from the given statements. (+1, -0.33)

Statement 1: All stones are cyclones

Statement 2: All cyclones are tornadoes

Conclusion I: Some tornadoes are stones

Conclusion II: Some cyclones are stones

- a. Only conclusion II follows
- b. Only conclusion I follows
- c. Neither I nor II follows
- d. Both I and II follow

-
45. Identify the metal having the lowest thermal conductivity. (+1, -0.33)

- a. Copper
- b. Mercury
- c. Aluminium
- d. Silver

-
46. Choose the figure that is different from the rest. (+1, -0.33)

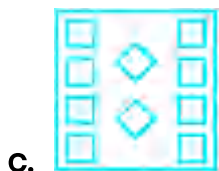
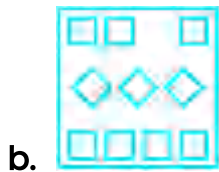
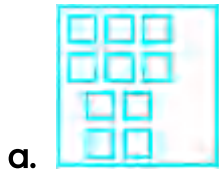

47. Two cows G and H are grazing in a field. They start from the same point. G (+1, -0.33) moves 1.5 km South, then turns East and moves 2.5 km, then turns to its right and moves 3.5 km. Meanwhile H has moved 2.5 km East. Where is H with respect to G.

- a. H is 2 km South of G
- b. H is 5 km North of G
- c. H is 5 km South of G
- d. H is 2 km North of G

48. Identify the non-metal, having high thermal conductivity. (+1, -0.33)

- a. Wood

- b. Water
 - c. Ice
 - d. Insulating brick
-

49. In a certain code language, if STUDIO is coded as QRSBGM, then how will RAW be coded in that language? (+1, -0.33)

- a. PYU
 - b. WXR
 - c. UKN
 - d. TGB
-

50. X jogs a total of 7.5 km in a day. He jogged $\frac{25}{6}$ km in the morning. How much did he jog in the Evening? (+1, -0.33)

- a. $\frac{5}{3}$ Km
 - b. $\frac{8}{3}$ Km
 - c. $\frac{11}{3}$ Km
 - d. $\frac{10}{3}$ Km
-

51. The sum of the present ages of a father and a son is 45 year. 5 year ago, the ratio of their ages was 6 : 1. Find the current age of the father. (+1, -0.33)

- a. 40 year
- b. 30 year

- c. 25 year
- d. 35 year

52. In the following figure, square represents Asians, triangle represents writers, circle represents fathers and rectangle represents actors. Which set of letters represents actors who are writers? (+1, -0.33)

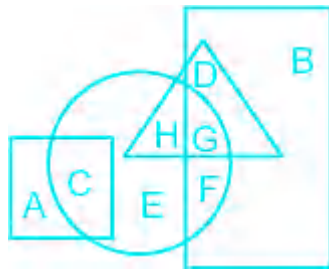

- a. GD
- b. GF
- c. CEG
- d. HGF

prepp

Your Personal Exams Guide

53. In the question, two statements are given, followed by three conclusions, I, II and III. You have to consider the statements to be true even if they seem to be at variance from commonly known facts. You have to decide which of the given conclusions, if any, follow(s) from the given statements. (+1, -0.33)

Statement 1: All bamboo are tall.

Statement 2: All tall are grass.

Conclusion I: Some grass are bamboo.

Conclusion II: Some tall are bamboo.

Conclusion III: Some grass are tall.

- a. All conclusions I, II and III follow
 - b. Only conclusions I and III follow
 - c. Only conclusions II and III follow
 - d. Only conclusions I and II follow
-

54. Identify the insulator from the below having high resistivity. (+1, -0.33)

- a. Glass
 - b. Diamond
 - c. Hard rubber
 - d. Dry paper
-

55. An object is accelerating at 5 m/s^2 from its rest position. The velocity of this object after 5 s is: (+1, -0.33)

- a. 15 m/s
 - b. 20 m/s
 - c. 5 m/s
 - d. 25 m/s
-

56. Two trains start moving towards each other when they are 2000 meter apart. First train travels at the speed of 20 m/s and the other one at 30 m/s. After how many seconds do they meet? (+1, -0.33)

- a. 45
 - b. 40
 - c. 35
 - d. 50
-

57. An object travels distance of first 30 m in 5 s and the next distance of 30 m in 3 s. The average speed of the object is: (+1, -0.33)

- a. 6.5 m/s
 - b. 9.0 m/s
 - c. 4.5 m/s
 - d. 7.5 m/s
-

58. What is the digit that will come at the unit's place in the result of $(423)^{423} \times (1237)^{28}$? (+1, -0.33)

- a. 9
 - b. 7
 - c. 1
 - d. 3
-

59. Which type of pencil has the hardest graphite lead? (+1, -0.33)

- a. 3H

- b. 2H
 - c. 9H
 - d. HB
-

60. In a Class 2 lever, effort and load move in the: (+1, -0.33)

- a. same direction
 - b. the movement depends on the load
 - c. opposite direction
 - d. perpendicular direction
-

61. How much heat should be transferred to the 100 g of an edible oil to raise its temperature by 20°C? (Specific heat of oil 1965 Jkg⁻¹ K⁻¹) (+1, -0.33)

- a. 4.31 kJ
 - b. 2.70 kJ
 - c. 1.32 kJ
 - d. 3.93 kJ
-

62. In a certain code language, 512 means 'steel makes tower', 175 means 'brick makes tower', and 327 means 'brick and steel'. Find the code for 'and'. (+1, -0.33)

- a. 3
- b. 1

c. 2

d. 7

63. Find the odd word from the given alternatives

(+1, -0.33)

a. Carom board

b. Wheel

c. Coin

d. Hula hoop

64. A 'compass' is used to draw:

(+1, -0.33)

a. Circle

b. Rectangle

c. Triangle

d. Straight line

65. If $G + H$ means G is daughter of H ; $G - H$ means G is father-in-law of H ; and $G * H$ means G is husband of H ; then which of the following shows that O is the sister of L ?

(+1, -0.33)

a. $O * N - M + L$

b. $O - N * M + L$

c. $O + M - N * L$

d. $O - N + M * L$

66. A sum of Rs. 10000 was deposited in a bank that offer 20% annual compound interest. What will the amount be in the bank after 2 year? (+1, -0.33)

a. Rs. 12000

b. Rs. 8000

c. Rs. 14400

d. Rs. 13600

67. Pipes A and pipe B can fill a tank at rate of $30 \text{ m}^3/\text{hr}$ and $40 \text{ m}^3/\text{hr}$ respectively. Together they fill the tank in 4 hours. Find the volume of the tank. (+1, -0.33)

a. 180 m^3

b. 280 m^3

c. 360 m^3

d. 200 m^3

68. What is the side of a cube if the total surface area is 96 sq. cm? (+1, -0.33)

a. 3 cm

b. 5 cm

c. 4 cm

d. 2 cm

69. Read the question below followed by two statements. Study them and decide which statement(s) is/are sufficient to answer the question. (+1, -0.33)

Question: What was the revenue of the zoo on a certain day?

Statements:

- I) 120 person visited the zoo on that certain day.
 - II) A discount of 25% on ticket price was offered on that certain day.
- a. Neither statement I nor II is sufficient
 - b. Statement I alone is sufficient while II alone is not sufficient
 - c. Statement II alone is sufficient while I alone is not sufficient
 - d. Either statement I or II is sufficient
-

70. A sheet of styrofoam of thickness 2 cm and area 0.1 m^2 has a temperature difference of 30°C between its inner and outer surfaces. Considering thermal conductivity as 0.01 J/s m K , the rate of heat flow through the sheet is: (+1, -0.33)

- a. 3.0 J/s
 - b. 2.0 J/s
 - c. 1.0 J/s
 - d. 1.5 J/s
-

71. A ball of 200 g is thrown vertically upward with a speed of 20 m/s. The momentum of the ball at the highest point of its path is (take $g = 10 \text{ m/s}^2$): (+1, -0.33)
- a. 200 kgm/s
 - b. 100 kgm/s
 - c. 40 kgm/s
 - d. 0
-

72. Given below is a statement followed by two assumptions numbered I and II. You have to decide which of the assumptions is/are implicit in the statement. (+1, -0.33)
- Statement:** College students should work during summer holidays to improve their chances of getting a job.
- Assumption I:** Not all college students want a job.
- Assumption II:** There are enough summer jobs for most college students.
- a. Both I and II are implicit
 - b. Only assumption I is implicit
 - c. Neither I nor II is implicit
 - d. Only assumption II is implicit
-

73. What will be A's share of profit if the total profit is Rupees 1000 and is to be divided amongst A, B and C in the ratio 3 : 2 : 5? (+1, -0.33)
- a. Rs. 250

- b. Rs. 300
- c. Rs. 500
- d. Rs. 200

74. If we compare the effort arm length with the load arm length in a class 1 lever, _____ (+1, -0.33)

- a. effort arm length is always $<$ load arm length
- b. effort arm length is always $=$ load arm length
- c. effort arm length is always $>$ load arm length
- d. effort arm length can be greater than, equal to or less than the length of the load arm

75. Increasing the pressure on an object _____ the volume of the object and therefore _____ its density. (+1, -0.33)

- a. increases, increases
- b. increases, decreases
- c. decreases, increases
- d. decreases, decreases

76. If we compare the effort arm length with the load arm length in a Class 2 lever, _____ (+1, -0.33)

- a. effort arm length is always $=$ load arm length

- b. effort arm length can be greater than, equal to or less than the length of the load arm
 - c. effort arm length is always $>$ load arm length
 - d. effort arm length is always $<$ load arm length
-

77. A source of voltage V maintains a current I in a circuit. The power (P) input to the circuit by the source is given by: (+1, -0.33)

- a. $P = VI$
 - b. $P = V/I$
 - c. $P = I/V$
 - d. $P = 1/(VI)$
-

78. If we double the length of a copper wire keeping the cross-sectional area constant, its resistance increases by _____ times. (+1, -0.33)

- a. Four
 - b. One
 - c. Three
 - d. Two
-

79. Which of these is NOT a novel written by Premchand? (+1, -0.33)

- a. Godaan
- b. Gaban

- c. Nirmala
- d. Deepshikha

80. The Celsius temperature (t_C) and the Fahrenheit temperature (t_F) are related as: (+1, -0.33)

- a. $t_F = (5/9)t_C + 32$
- b. $t_F = (9/5)t_C$
- c. $t_F = (9/5)t_C + 32$
- d. $t_F = (5/9)t_C$

81. What is the square root of 0.000225? (+1, -0.33)

- a. 0.0125
- b. 0.0015
- c. 0.005
- d. 0.015

82. $\triangle DEF$ is similar to $\triangle PQR$. If the ratio of semi-perimeter of $\triangle DEF$ and $\triangle PQR$ is 4 : 5 and if $PQ = 15\text{cm}$, then the length of DE is: (+1, -0.33)

- a. 12 cm
- b. 10 cm
- c. 20 cm

d. 8 cm

83. Which country did India beat to win the Under19 Cricket Asia Cup 2018? (+1, -0.33)

- a. Sri Lanka
 - b. Afghanistan
 - c. Pakistan
 - d. Bangladesh
-

84. The view of an object produced on a vertical plane is referred to as: (+1, -0.33)

- a. Right hand side view
 - b. Top view
 - c. Front view
 - d. Left hand side view
-

85. Who was appointed as the Chief Justice of India on 03.10.2018? (+1, -0.33)

- a. Mr. N.V. Ramana
 - b. Mr. Ranjan Gogoi
 - c. Mr. Kurian Joseph
 - d. Mr. Arjan Kumar Sikri
-

86. The specific heat capacity of a substance is defined by: (+1, -0.33)

- a. $m(\Delta Q/\Delta T)$
 - b. $m(\Delta T/\Delta Q)$
 - c. $(1/m)(\Delta Q/\Delta T)$
 - d. $(1/m)(\Delta T/\Delta Q)$
-

87. 10% of 1000% of 100 = ? (+1, -0.33)

- a. 110
 - b. 100
 - c. 102
 - d. 105
-

88. A pair of plier and scissor are together considered as a _____ Class 1 lever. (+1, -0.33)

- a. triple
 - b. single
 - c. double
 - d. simple
-

89. A component that adds to a software program's functionality is called as _____ (+1, -0.33)

- a. Plug-in

- b. Processor
- c. Modem
- d. Server

90. If C% D means C is the wife of D; C & D means C is the father of D; and If C D means C is the daughter of D, then what would X Y % W & Z mean if W has only one daughter? (+1, -0.33)

- a. X is the son of Z
- b. Z is the sister of X
- c. Z is the sister of the mother of X
- d. X is the sister of Z

91. Our electricity bills carry the energy consumption, expressed in units of ----- (+1, -0.33)

- a. KVA
- b. kW
- c. kWh
- d. KJ

92. The length and breadth of a rectangle is 6 cms and 8 cms respectively. Then what will be the area of a square whose side is equal to the length of the diagonal of this rectangle. (+1, -0.33)

- a. 100 cm^2

- b. 92 cm^2
 - c. 96 cm^2
 - d. 196 cm^2
-

93. A series is given, with one number missing. Choose the correct alternative (+1, -0.33) from the given ones that will complete the series.

7.4, 8.7, 10.0, 11.3, ?, 13.9

- a. 11.9
 - b. 12.3
 - c. 11.7
 - d. 12.6
-

94. The median of 2, 9, 11, 7, 3, 4, 8, 5, 3, 6 is: (+1, -0.33)

- a. 3.5
 - b. 5
 - c. 5.5
 - d. 4
-

95. An article was marked for Rs. 1000. Had a discount of 16% was offered, a profit of 5% would have been made. What is the cost price of the article? (+1, -0.33)

- a. Rs. 750

- b. Rs. 800
 - c. Rs. 880
 - d. Rs. 840
-

96. Find the odd set of letter from the given alternatives. (+1, -0.33)

- a. JLN
 - b. MNO
 - c. RTV
 - d. CEG
-

97. Standing up and supporting the lower back with hands, then gently arching back and holding this posture for some time is called as: (+1, -0.33)

- a. Finger fan
 - b. Back arching
 - c. Wrist stretch
 - d. Pectoral stretch
-

98. Which two signs should be interchanged to correct the given equation? (+1, -0.33)

$$15 \div 3 + 2 \times 10 - 6 = 14$$

- a. \div and $-$
- b. \div and $+$

c. + and ×

d. + and -

99. Which of these is NOT a type of string musical instrument?

(+1, -0.33)

a. Bass

b. Violin

c. Tuba

d. Cello

100. What was the day of the week on January 26, 1989?

(+1, -0.33)

a. Tuesday

b. Thursday

c. Sunday

d. Monday

prepp
Your Personal Exams Guide

Part B

101. In the context of cables, FRC stands for: (+1, -0.33)

- a. Full Rolling Cable
 - b. Fat Ribbon Cable
 - c. Fast Reeling Cable
 - d. Flat Ribbon Cable
-

102. What is the use of an RTD? (+1, -0.33)

- a. Measuring temperature
 - b. Measuring pressure
 - c. Measuring humidity
 - d. Measuring position
-

103. Which of the following shows the proper biasing of a PNP transistor? (+1, -0.33)

- a. base and emitter - forward bias; collector and emitter - reverse bias
- b. base and emitter - forward bias; collector and emitter - forward bias
- c. base and emitter - reverse bias; collector and emitter - forward bias
- d. base and emitter - reverse bias; collector and emitter - reverse bias

104. In an op-amp, the input impedance is _____ and the output impedance is _____. (+1, -0.33)
- a. high; high
 - b. low; low
 - c. low; high
 - d. high; low
-

105. Which of the following devices requires a battery? (+1, -0.33)
- a. Step-up chopper
 - b. stabilizer
 - c. Step-down chopper
 - d. UPS
-

106. 10 cells each with an EMF of 1.5 V and an internal resistance of 0.1 Ω are connected in series. What will be the total EMF and resistance of the circuit? (+1, -0.33)
- a. 3.21 V and 1.5 Ω
 - b. 1.18 V and 1.5 Ω
 - c. 4.15 V and 2.0 Ω
 - d. 15 V and 1.0 Ω
-

107. In an amplifier with a positive feedback circuit, gain: (+1, -0.33)
- a. Decreases
 - b. remains constant
 - c. Increases
 - d. first increases and then decreases
-

108. A full-wave bridge rectifier consists of: (+1, -0.33)
- a. one diode
 - b. two diodes
 - c. three diodes
 - d. four diodes
-

109. A circuit that changes a code into a set of signals is called (+1, -0.33)
- a. Encoder
 - b. multiplexer
 - c. Decoder
 - d. Selector
-

110. For which of the following gates the output is zero when one or more inputs are zero? (+1, -0.33)

- a. OR
 - b. NOR
 - c. NOT
 - d. AND
-

111. Fibre cables used for 'Fibre to Home' installations are _____ . (+1, -0.33)

- a. multimode graded
 - b. multimode step
 - c. multiaxis
 - d. single mode
-

112. Which of the following circuit has its output dependent only upon the present input? (+1, -0.33)

- a. Analog Circuits
 - b. Flip Flops
 - c. Combinational Circuits
 - d. Sequential Circuits
-

113. The output impedance of a MOSFET is: (+1, -0.33)

- a. Medium impedance
- b. Low impedance

- c. Extreme high impedance
 - d. High impedance
-

114. The waveform in a DSO is stored in _____ form. (+1, -0.33)

- a. Digital
 - b. Expanded
 - c. Analog
 - d. Mixed
-

115. Which of the following is a function of an inductor? (+1, -0.33)

- a. It opposes the flow of AC
 - b. It allows the flow of current.
 - c. It opposes the flow of DC.
 - d. It opposes the flow of both AC and DC.
-

116. 78xx series ICs are: (+1, -0.33)

- a. zener regulated
 - b. series regulated
 - c. shunt regulated
 - d. series and shunt regulated
-

117. In MS Excel, we cannot calculate: (+1, -0.33)
- a. division solutions
 - b. integration solutions
 - c. arithmetic solutions
 - d. multiplication solutions
-

118. Eddy current proximity sensors can detect _____ (+1, -0.33)
- a. cotton
 - b. metal
 - c. wood
 - d. epoxy
-

119. CRO stands for: (+1, -0.33)
- a. Cathode Relay Oscilloscope
 - b. Cathode Ray Oscilloscope
 - c. Cathode Rectifier Oscilloscope
 - d. Cathode register oscilloscope
-

120. An IC with four NOR gates is: (+1, -0.33)
- a. 7486
-

- b. 7404
 - c. 7432
 - d. 7402
-

121. Windows 10 is a/an: (+1, -0.33)

- a. booting system
 - b. operating and booting system
 - c. operating system
 - d. counting pulse
-

122. Impedance can be measured by using which of the following equipment? (+1, -0.33)

- a. CRO
 - b. LCR meter
 - c. Function generator
 - d. DSO
-

123. In a bipolar transistor, alpha is the ratio of: (+1, -0.33)

- a. collector current to emitter current
- b. emitter current to collector current
- c. base current to collector current

d. collector current to base current

124. Race Around condition can be avoided in Digital logic circuits using? (+1, -0.33)

- a. Shift Register
 - b. Master Slave JK Flip Flop
 - c. Full Adder
 - d. AND Gate
-

125. In two-stage RC coupling, the function of a C_c capacitor is: (+1, -0.33)

- a. to allow AC and DC to pass
 - b. to block AC and DC
 - c. to block DC voltage
 - d. to block AC input signal
-

126. A _____ can be represented as two port linear network. (+1, -0.33)

- a. common base
 - b. common collector
 - c. common emitter
 - d. hybrid parameter
-

127. A capacitor consists of _____ metal plates separated by an insulator. (+1, -0.33)
- a. Three
 - b. Two
 - c. four
 - d. one
-

128. What is the frequency band of shortwave radio transmission? (+1, -0.33)
- a. 1.7 to 30 GHz
 - b. 1.7 to 30 MHz
 - c. 1.7 to 30 kHz
 - d. 1.7 to 30 Hz
-

129. What will be the power required by a bulb load having a resistance of 50Ω if the voltage applied is 220 V? (+1, -0.33)
- a. 828 W
 - b. 1068 W
 - c. 968 W
 - d. 200 W
-

130. Which of the following is an application of transformers? (+1, -0.33)

- a. AC to AC conversion with isolation
 - b. Regulate DC voltage
 - c. DC to AC conversion
 - d. AC to DC conversion
-

131. If current = 1.414 A and resistance = 50 Ω , then find power. (+1, -0.33)

- a. 400 Watts
 - b. 100 Watts
 - c. 300 Watts
 - d. 200 Watts
-

132. What is the number of cycles completed by a 50-Hz line in 10 seconds? (+1, -0.33)

- a. 5000
 - b. 5
 - c. 500
 - d. 50
-

133. Input ripple of SMPS is _____ . (+1, -0.33)

- a. high
- b. nil

- c. very low
 - d. low
-

134. UJT is not used for: (+1, -0.33)

- a. timing circuits
 - b. phase control
 - c. triggering an SCR/TRIAC
 - d. amplification
-

135. The output of Schmitt trigger is: (+1, -0.33)

- a. Sine wave
 - b. Square wave
 - c. Random wave
 - d. Rectangle wave
-

136. Which component of a digital panel meter converts analogue signals into a digital format? (+1, -0.33)

- a. ADC
- b. comparator
- c. magnetic field sensor
- d. hall sensor

137. Which of the following is a function of a resistor? (+1, -0.33)

- a. It both allows and opposes the flow of current.
 - b. It opposes the flow of current.
 - c. It allows the flow of current.
 - d. It neither allows nor opposes the flow of current.
-

138. Heat sink of a power transistor can be used for: (+1, -0.33)

- a. additional heat observation
 - b. additional heat dissipation
 - c. additional heat dissolution in water
 - d. increasing the heat
-

139. Transformer losses are due to: (+1, -0.33)

- a. core and copper losses
 - b. primary loss
 - c. only core losses
 - d. only copper losses
-

140. Which of the following is used as a receiver for fibre optic communication? (+1, -0.33)

- a. LED
 - b. IR diode
 - c. Photo diode
 - d. LDR
-

141. In 8051 microcontroller the resultant of two numbers added is (+1, -0.33)

-----.

- a. Erased
 - b. not stored anywhere
 - c. stored in the accumulator
 - d. stored in the register
-

142. The following short name is also called as _____ for diode (+1, -0.33)
alternating current.

- a. DIAC
 - b. SCR
 - c. FET
 - d. TRIAC
-

143. The binary representation for the hexadecimal number 4A is: (+1, -0.33)

- a. 101111

- b. 111101
 - c. 101101
 - d. 1001010
-

144. The motor used in household refrigerators is (+1, -0.33)

- a. single phase induction motor
 - b. Hysteresis motor
 - c. dc series motor
 - d. Reluctance motor
-

145. A push-pull amplifier is used for: (+1, -0.33)

- a. voltage amplification
 - b. current amplification
 - c. RF signal amplification
 - d. power amplification
-

146. Which of the following statements is true with respect to a Primary Cell? (+1, -0.33)

- a. It can neither be recharged nor be reused.
- b. It cannot be recharged but can be reused.
- c. It can be recharged and reused.

d. It can be recharged but cannot be reused.

147. Most widely used solar cell material is

(+1, -0.33)

- a. steel
 - b. silicon
 - c. mercury
 - d. Cast iron
-

148. Burglar alarm circuits consist of

(+1, -0.33)

- a. LCDs
 - b. VCDs
 - c. LVDs
 - d. IRLEDs
-

149. What happens if a capacitor is placed in parallel with a DC source?

(+1, -0.33)

- a. It amplifies the voltage.
 - b. The circuit acts as an open circuit.
 - c. The circuit acts as a short circuit.
 - d. It converts DC to AC.
-

150. If a capacitor is placed in the feedback path of an op-amp circuit, then the circuit can act as (+1, -0.33)
- a. integrator
 - b. multiplier
 - c. divider
 - d. subtractor
-

151. The device used for converting continuous DC to discontinuous DC is known as a/an _____ (+1, -0.33)
- a. chopper
 - b. rectifier
 - c. oscillator
 - d. amplifier
-

Your Personal Exams Guide

152. A limiter circuit is also known as a: (+1, -0.33)
- a. clamp circuit
 - b. chopping circuit
 - c. clipper circuit
 - d. chopper circuit
-

153. Forward biasing of a PN junction diode is indicated by which of the following connections? (+1, -0.33)
- a. -ve to anode and +ve to cathode for full cycle
 - b. +ve to anode and -ve to cathode for full cycle
 - c. +ve to cathode and -ve to anode for one half cycle, and +ve to anode and -ve to cathode for the second half cycle.
 - d. -ve to cathode and -ve to anode for full cycle
-

154. For pulse generation, the IC used is: (+1, -0.33)
- a. 7402
 - b. 555
 - c. 7805
 - d. 7432
-

155. What is the material used for the manufacture of fiber optic cables? (+1, -0.33)
- a. Wood
 - b. Steel
 - c. Plastic
 - d. Glass
-

156. The source of light for optic fibre transmission is _____ . (+1, -0.33)
-

- a. ARC lamp
 - b. LED
 - c. mercury lamp
 - d. incandescent lamp
-

157. BC 194 is the transistor used for: (+1, -0.33)

- a. the amplification of AF and RF signals
 - b. the rectification of AC
 - c. the amplification of AF signal
 - d. the amplification of RF signal
-

158. How many counter/timer does the 8051 microcontroller have? (+1, -0.33)

- a. 2
 - b. 8
 - c. 4
 - d. 1
-

159. The frequency of the rotor current in an induction motor is equal to: (+1, -0.33)

- a. slip \times input frequency
- b. slip \times stator current

- c. half of the input frequency
 - d. the stator current
-

160. What is unity gain amplifier also known as? (+1, -0.33)

- a. Voltage follower
 - b. Comparator
 - c. Single sided
 - d. Differential
-

161. What happens to the resistance of an RTD with an increase in temperature? (+1, -0.33)

- a. It is uncertain.
 - b. It increases.
 - c. It remains the same.
 - d. It decreases.
-

162. 16-bit registers consist of: (+1, -0.33)

- a. 16 flip-flops
 - b. 20 flip-flops
 - c. 12 flip-flops
 - d. 8 flip-flops
-

163. Cells are connected in series in order to (+1, -0.33)

- a. Decrease the voltage
 - b. Increase the Voltage
 - c. Increase the current
 - d. Increase the cell life
-

164. The combination of two half adders is a _____. (+1, -0.33)

- a. full adder
 - b. Schimtt trigger
 - c. Comparator
 - d. half adder
-

165. The average value of sine wave is _____ times the peak value. (+1, -0.33)

- a. 1.414
 - b. 0.637
 - c. 2.414
 - d. 1.732
-

166. Identify the type of antenna shown in the following picture. (+1, -0.33)

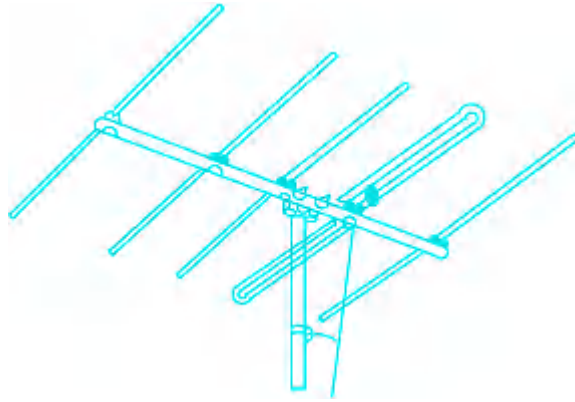

- a. Circular
- b. Bi-pole
- c. Monopole
- d. Yagi

167. Sine Wave RMS = ----- (+1, -0.33)

- a. Peak voltage/Square root of 5
- b. Peak voltage/Square root of 2
- c. Peak voltage/Square root of 6
- d. Peak voltage/Square root of 3

168. The following figure represents a/an ----- (+1, -0.33)



- a. HEATER
- b. FUSE

- c. MCB
 - d. SWITCH
-

169. The power factor of a D.C. circuit is always (+1, -0.33)

- a. Leading
 - b. Unity
 - c. Lagging
 - d. zero
-

170. In simple oscillators, _____ are used. (+1, -0.33)

- a. UJTs
 - b. zener diodes
 - c. SCRs
 - d. TRIACs
-

171. An LVDT is used for measuring _____ (+1, -0.33)

- a. frequency
 - b. speed
 - c. temperature
 - d. displacement
-

172. The gain of an amplifier with feedback is known as _____ gain. (+1, -0.33)

- a. High
- b. Open loop
- c. Closed loop
- d. Low

173. In case of an AC input signal in CE Transistor Load line can be given by a plot of (+1, -0.33)

- a. VCE & Ic
- b. VBE vs Ic
- c. VCE & Rc
- d. VBE vs Ib

174. The current towards a junction is: (+1, -0.33)

- a. twice the current towards the junction
- b. equal to the current away from the junction
- c. equal to the sum of currents towards the junction
- d. not equal to the current away from the junction

175. How can a higher voltage be obtained from a solar cell? (+1, -0.33)

- a. By connecting multiple cells in series
- b. By increasing its thickness
- c. By connecting multiple cells in parallel
- d. By decreasing its thickness

prepp

Your Personal Exams Guide

Answers

1. Answer: d

Explanation:

Concept:

Least 5 digit number = 10,000

But 10,000 is not exactly divisible by 97

Now $10,000 / 97 = 9$ (remainder)

Subtract remainder from divisor

Remainder = 9, Divisor = 97

$\Rightarrow 97 - 9 = 88$

Now add this result in 10,000

$10,000 + 88 = 10088$ is the least number which is divisible by 97

Sum of digits of 10088 = $1 + 0 + 0 + 8 + 8 = 17$

2. Answer: a

Explanation:

The correct answer is Meghalaya.

★ Key Points

- **Laho dance** belongs to the state of Meghalaya in India.
-
- It is **performed** during the **Behdienkhlam festival**.

- It is performed by **both men and women**.
- **Jaintia**tribe perform this dance festival.
- **Derogata ,Dodrua, Shad nongkrem** are some of the dance festivals of Meghalaya.

3. Answer: b

Explanation:

The Venn diagram that best represents the relationship between women, mother, and doctor is shown below:

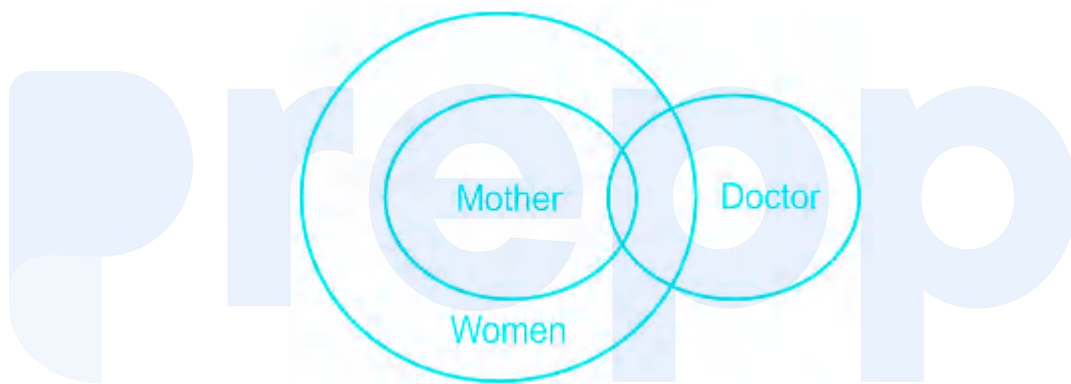

All mothers are women and some women are Doctors. Also, there are some women doctors who are mothers too. Therefore, the above diagram best describes the relationship.

Hence, ' option 2 ' is the correct answer.

4. Answer: c

Explanation:

The correct answer is 7×10^2 .

- Let the total volume of the wooden block = 100

- Given, the Volume above water = 30% of 10 = 30
- Therefore, Volume inside water = 70
- **Upward buoyant force that is exerted on a body immersed in a fluid = weight of the fluid that the body displaces ,**
 - Upward buoyant force = Density of the water × Volume of wood inside the water
 - Upward buoyant force = $1000 \times 70 = 70000 \text{ N}$
 - Weight of the fluid that the body displaces = Density of the Wooden block × Volume of the Wooden block
 - Weight of the fluid that the body displaces = Density of the Wooden block × 100
 - Hence,
 - Density of the Wooden block × 100 = 70000
 - **Density of the Wooden block = 7×10^2**

★ Additional Information

- Archimedes' principle states that the upward buoyant force that is exerted on a body immersed in a fluid, whether fully or partially, is equal to the weight of the fluid that the body displaces.

5. Answer: a

Explanation:

The logic is:

$$2/5 : 0.4 \rightarrow 2 \div 5 = 0.4$$

Similarly,

$$1/200 : ? \rightarrow 1 \div 200 = 0.005$$

Hence, '0.005' is the correct answer.

6. Answer: d

Explanation:

Formula:

$$\text{Distance between two points} = \sqrt{(x_1 - x_2)^2 + (y_1 - y_2)^2}$$

Given:

$$x_1 = -2, x_2 = 4, y_1 = 4, y_2 = 4$$

Calculation:

$$\sqrt{(-2 - 4)^2 + (4 - 4)^2}$$

$$\Rightarrow \sqrt{(-6)^2 + 0}$$

$$\Rightarrow \sqrt{36}$$

$$\Rightarrow 6 \text{ units}$$

7. Answer: d

Your Personal Exams Guide

Explanation:

The correct answer is Option 4, i.e. Operating System.

- An Operating system (OS) is the software that manages all of a computer's processes and allows programs and applications to run.
- Microsoft Windows, Apple's macOS, Chrome OS, BlackBerry Tablet OS are some examples of OS.
- The first operating system was created by **General Motors in 1956**.
- It was used to run a **IBM mainframe computer**.
- **Spam** is electronic junk mail or junk newsgroup postings.

- **Malware** , or malicious software, is any program or file that is harmful to a computer user. Types of malware can include computer viruses, worms, Trojan horses and spyware.
 - **Modem** is short for "Modulator-Demodulator." It is a hardware component that allows a computer or another device, such as a router or switch, to connect to the Internet.
-

8. Answer: a

Explanation:

- 1) Some worker who were promoted in the last five year are hardworking → True
(As, all hardworking worker in the factory have been promoted in the last five year)
- 2) There are no worker in the factory who are not hardworking → False
It is not mentioned that all the workers are hardworking.
- 3) Hardworking is the only criteria for promotion → False
It is not mentioned in the statement that hardwork is the only criteria.
- 4) After promotion, some worker stopped working hard → False
It is not mentioned in the statement.
- Hence, only conclusion I follows.
-

9. Answer: a

Explanation:

Given:

In second year amount = Rs. 800

In third year amount = Rs. 840

Interest earned in one year = $840 - 800 = \text{Rs.}40$

Formula:

$(\text{Interest earned} / \text{amount of 2}^{\text{nd}} \text{ year}) \times 100$

Calculation:

$(40 / 800) \times 100 = 5\%$

10. Answer: b

Explanation:

In all the figures except option '2', there are 3 triangles and 4 semi-circles, while in option 2 there are 4 triangles and 4 semi-circles.

Hence, 'option 2' is the odd one out.

11. Answer: a

Explanation:

Follow BODMAS rule to solve this question, as per the order given below.

Step - 1: Parts of an equation enclosed in 'Brackets' must be solved first, and following BODMAS rule in the bracket -

Step - 2: Any mathematical 'Of' or 'Exponent' must be solved next.

Step - 3: Next, the parts of the equation that contain 'Division' and 'Multiplication' are calculated.

Step - 4: Last but not the least, the parts of the equation that contain 'Addition' and 'Subtraction' should be calculated.

$$0.5 \div 12.5 + 0.25 \times 0.05 - 0.0125 = ?$$

$$\Rightarrow 0.04 + 0.25 \times 0.05 - 0.0125 = ?$$

$$\Rightarrow 0.04 + 0.0125 - 0.0125 = ?$$

$$\therefore ? = 0.04$$

★ Alternate Method

$$5/10 \div 125/10 + 25/100 \times 5/100 - 125/1000$$

$$\Rightarrow 5/10 \times 10/125 + 1/80 - 1/80$$

$$\Rightarrow 5/125 = 1/25 = 0.04$$

12. Answer: b

Explanation:

The correct answer is Option 2, i.e 70%

- **Biogas** contains up to 70% Methane.
- Biogas contains **Methane gas, Carbon dioxide** , and amounts of **Nitrogen ,H ydrogen, and carbon monoxide**.
- It is produced from materials such as agricultural waste, manure, municipal waste, plant material, sewage, green waste, etc.
- Biogas is produced by anaerobic digestion.

13. Answer: b

Explanation:

Concept:

Thermal Expansion:

- Thermal expansion is the phenomenon observed in solids, liquids, and gases. In this process, an object or body expands on the application of heat (temperature).
- It defines **the tendency of an object to change its dimension either in length, density, area, or volume due to heat. When the substance is heated it increases its kinetic energy.**
- **Thermal expansion is of three types:** Linear expansion, Area expansion, Volume expansion

Linear Expansion:

- **Linear expansion is the change in length due to heat.**
- The linear expansion formula is given as, $\frac{\Delta L}{L} = \alpha_L \Delta T$, where ΔL = change in length, L = original length, ΔT = change in temperature, α_L = coefficient of linear expansion

Volume Expansion:

- **Volume expansion is the change in volume due to temperature.**
- The volume expansion formula is given as, $\frac{\Delta V}{V} = \alpha_V \Delta T$, where ΔV = change in volume, V = original volume, ΔT = change in temperature, α_V = coefficient of volumetric expansion

Area Expansion:

- **Area expansion occurs as the change in area due to temperature change.**
- The area expansion formula is given as, $\frac{\Delta A}{A} = \alpha_A \Delta T$, where ΔA = change in the area, A = original area, ΔT = change in temperature, α_A = coefficient of area expansion

Explanation:

- The coefficient of linear expansion of iron is $11 \times 10^{-6} \text{ K}^{-1}$.
- The coefficient of linear expansion of brass is $19 \times 10^{-6} \text{ K}^{-1}$.
- The coefficient of linear expansion of copper is $16 \times 10^{-6} \text{ K}^{-1}$.
- The coefficient of linear expansion of lead is $29 \times 10^{-6} \text{ K}^{-1}$.

- Hence, from the above data, the Iron has the lowest coefficient of linear Expansion.

14. Answer: d

Explanation:

Symbol	+	-	×	÷
Meaning	×	+	÷	-

Given expression: $8 + 3 \times 4 - 2 = ?$

After replacing the symbols by their meaning, we get:

$$= 8 \times 3 \div 4 + 2$$

$$= 6 + 2$$

$$= 8$$

Hence, '8' is the correct answer.

15. Answer: a

Explanation:

The correct answer is Option 1, i.e **Tim Berner-Lee** .

- **Tim Berner-Lee** invented the World Wide Web.
- The full form of WWW is the **World Wide Web**.
- World Wide Web connected the world in a way that was not possible before and made it much easier for people to get information, share, and

communicate.

- It allowed people to share their work and thoughts through social networking sites, blogs, and video sharing.
 - He invented the World Wide Web in **1989** .
 - **Tim Berner-Lee** was knighted by **Queen Elizabeth II** in the year **2004** .
 - Internet Protocol was introduced by **Robert E. Kahn and Vint Cerf** in **1974**.
-

16. Answer: d

Explanation:

The correct answer is Option **4**, i.e. **IUCN**.

- **IUCN** prepares a **Red List of Threatened Species** .
 - **IUCN** stands for **International Union for Conservation of Nature** .
 - Its **Headquarters** is situated in **Gland, Switzerland** .
 - **Nanno Kleiterp** is the **Chairman** of **IUCN**.
 - It works in the field of **Nature Conservation and Sustainable use**.
-

17. Answer: a

Explanation:

The logic is:

Walnut : shell → The outer covering of a walnut is called a shell.

Similarly,

Banana : ? → The outer covering of a banana is called banana skin or banana peel.

Hence, 'peel' is the correct answer.

18. Answer: b

Explanation:

CONCEPT:

Work done:

It is the dot product of **Force** and **Displacement** .

Work Done (W) = Force (F) × Displacement (S)

Kinetic energy:

The energy of a particle due to its velocity is called kinetic energy.

It is denoted by K.E.

$$K.E = \frac{1}{2}mV^2$$

where m = mass of the particle and V = velocity of the particle.

Work energy theorem :

The work done by all the forces on a system is equal to change in kinetic energy of the system.

Work done by all the forces (W) = Final K.E – Initial K.E

CALCULATION:

Given that:

Initial velocity (u) = 4 m/s, final velocity (v) = 8 m/s and

Mass (m) = 0.5 kg

Applying the work-energy theorem:

Work done = Change in Kinetic Energy:

$$\Delta K.E = (K.E)_2 - (K.E)_1$$

$$\Rightarrow \frac{1}{2}m(v^2 - u^2)$$

$$\Rightarrow \frac{1}{2} \times 0.5 \times (8^2 - 4^2)$$

$\therefore \Delta K.E$ is 12 J

19. Answer: b

Explanation:

Concept:

The position of the title block should be within the drawing space such that the portion of the title block containing the identification of drawing is situated in the bottom right hand corner of the drawing space, both for sheets positioned horizontally and vertically.

The title block should contain:

1. Name of the firm.
2. Title of the drawing.
3. Scale.
4. Symbol for the method of projection.
5. Drawing number.
6. Initials with dates of persons who have designed, drawn, checked, standards and approved.
7. No. of sheet and total number of sheets of the drawing of the object.

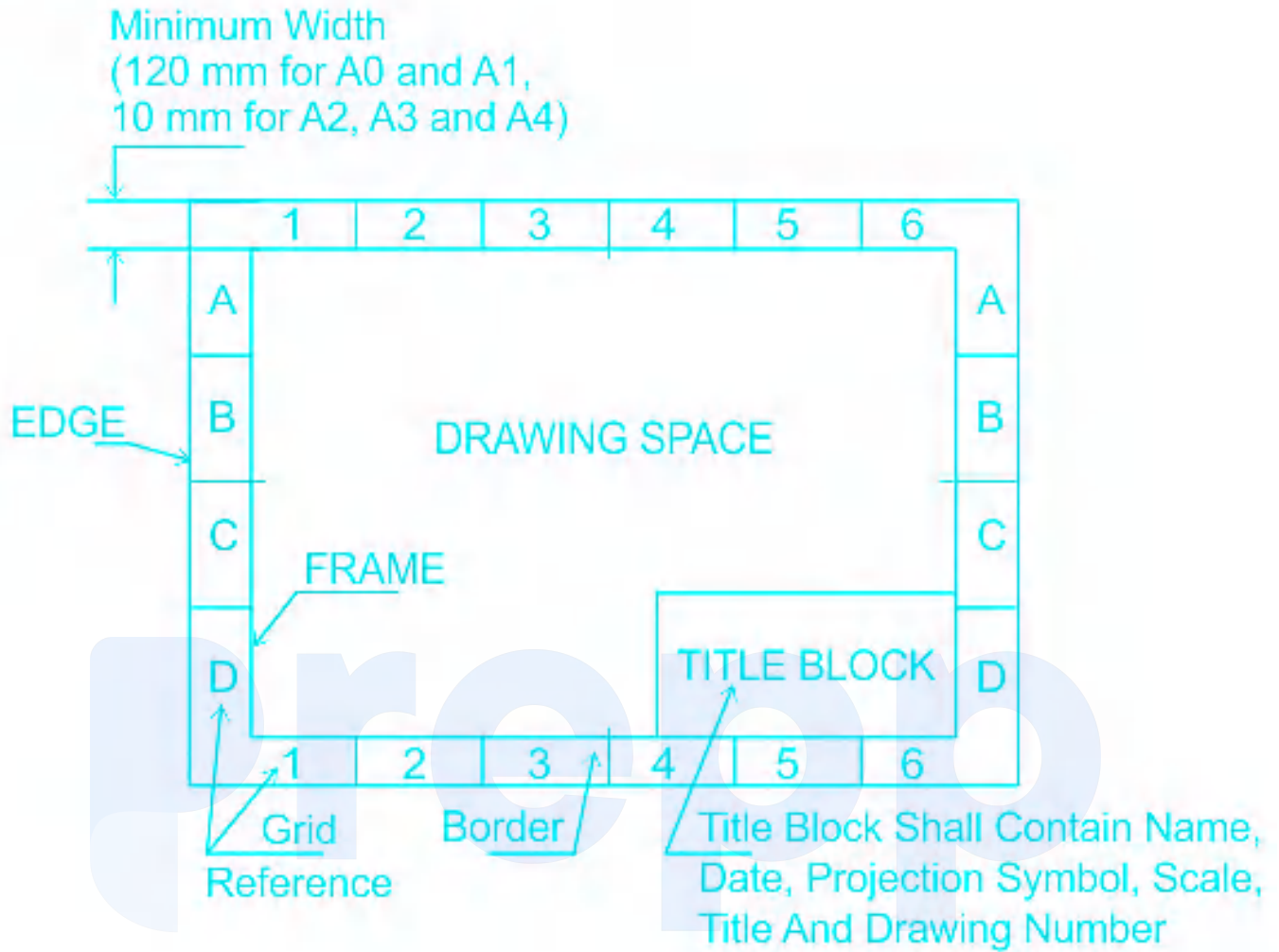

Your Personal Exams Guide

20. Answer: c

Explanation:

The correct answer is Option 3, i.e. Ashoka.

- The Construction of the "Sanchi Stupa" was commissioned by **Ashoka**.
- It is situated at Sanchi Town in Raisen District of Madhya Pradesh.
- It is also a **UNESCO World heritage site**.
- Its **official name** is **Buddhist Monument at Sanchi**.
- Sanchi Stupa number 1 has a large number of Brahmi Inscription .
- **Bindusara** was the son of the dynasty's founder **Chandragupta** .

- **Kautilya** or Chanakya (c. 350 – 283 B.C.E.) was an adviser and a Prime Minister to the first Maurya Emperor Chandragupta.

★ Key Points

- With the help of Chanakya (Vishnugupta/ Kautilya), Chandragupta Maurya defeated Dhana Nanda (322 BCE) and founded the Mauryan Dynasty.
- Chanakya encouraged Chandragupta Maurya and his army to take over the throne of Magadha.
- His vast empire included Bihar, Bengal, Deccan (except modern Kerala, Tamilnadu, and parts of Northeast India), Eastern Afghanistan, Baluchistan, and the area west of the Indus river.

★ Important Points

bindusara

- Chandragupta was succeeded by his son Bindusara.
- Bindusara ruled for approximately 25–26 years and his succession was disputed which ultimately gave India a great king called Asoka.

Ashoka

- Asoka was the third and the greatest of the Mauryan rulers.
- Ashoka is referred to as Ashokavardhana.

Kunala

- Kunala was the son of Emperor Ashoka and Queen Padmavati and the presumptive heir to Ashoka.

21. **Answer: d**

Explanation:

- Given, Length of second wire (L') = Half of length of first wire (L)
- Also, Radius of second wire (r') = Twice radius of radius of first wire (r)

- So, $L' = L/2$ and $r' = 2r$
- Let ρ be **Resistivity of material**.
 - $R = \rho L / A$
 - $R = \rho L / (\pi r^2)$; where $\pi r^2 =$ cross section Area of cylindrical wire
- For **second wire**,
 - $R' = \rho L' / (\pi r'^2)$
 - $R' = \rho(L/2) / (4\pi r^2)$
 - $R' = \rho L / (8\pi r^2)$
 - **$R' = R/8$**
- Resistance is **directly proportional to length** and **inversely proportional to area**.
- Its unit is Ohm.

22. Answer: d

Explanation:

CONCEPT:

- Acceleration due to gravity : The acceleration achieved by any object due to the gravitational force of attraction by any planet is called acceleration due to gravity by the earth.
 - As each planet has a different mass and radius so the acceleration due to gravity will be different for a different planet.
- Weight: The weight(w) of an object is the force of gravity on the object and may be defined as the mass(m) times the acceleration of gravity(g).
 - Weight is a force, the SI unit of weight is Newton.

Weight (W) = $m g$

Where m is mass and g is the acceleration due to gravity.

- The mass of the moon is $1/100$ times and the radius of the moon is $1/4$ times that of the earth.
- Since the acceleration due to the gravity of the moon is one-sixth of that of the earth.

- So Weight of any object on the Moon = $1/6 \times$ Weight of any object on the Earth's surface.

EXPLANATION:

Given: The weight of any object is **150 N** on an earth's surface

- The weight of the object on the Moon = $1/6 \times$ Weight of any object on the Earth's surface = $150 \times 1/6 = 25 \text{ N}$

23. Answer: c

Explanation:

Concept:

Equation of motion:

- Equations of motion of kinematics describe the basic concept of the motion of an object such as the position, velocity, or acceleration of an object at various times.
- These three equations of motion govern the motion of an object in 1D, 2D, and 3D.
- Three equations:
 1. $v = u + at$
 2. $s = ut + 0.5 at^2$
 3. $2as = v^2 - u^2$
- Here, u = initial velocity, v = final velocity, s = displacement, t = time
- **Under the influence of gravity, acceleration a is replaced by the acceleration due to gravity g .**

Calculation:

Given,

Initial velocity, $u = 0 \text{ m/s}$, Acceleration, $a = 3 \text{ m/s}^2$

From the first equation of motion, $v = u + at$

$$\text{at } t = 2 \text{ s, } v = 0 + 3 \times 2 = 6 \text{ m/s}$$

So, the velocity is 6 m/s at $t = 2$ s.

From the second equation of motion,

$$s = ut + 0.5 at^2$$

We need to calculate the displacement of the time interval (4 s to 2 s)

$$\text{Now, } s = (6 \times 2) + (0.5 \times 3 \times 2^2)$$

$$s = 18 \text{ m}$$

The average velocity can be calculated as,

$$v_{avg} = \frac{\text{total displacement}}{\text{total time duration}}$$

$$v_{avg} = \frac{18}{2} = 9 \text{ m/s}$$

Hence, What is its average velocity between time 2 s and 4 s is 9 m/s.

24. Answer: c

Your Personal Exams Guide

Explanation:

Let the number be x

Given

$$x + 16/x = 10$$

$$\Rightarrow x^2 + 16 = 10x$$

$$\Rightarrow x^2 - 10x + 16 = 0$$

$$\Rightarrow x^2 - 8x - 2x + 16 = 0$$

$$\Rightarrow x(x - 8) - 2(x - 8)$$

$$\Rightarrow (x - 8)(x - 2)$$

$$\Rightarrow x = 8, 2$$

Since there 8 in the option we have to choose 8.

25. Answer: b

Explanation:

CONCEPT:

- Power : The rate of work done is called power. It is denoted by P.

$$\text{Power (P)} = \text{Work done (W)}/\text{Time (t)}$$

- **Potential energy:** The energy of a body due to its position is called potential energy.

$$\text{Potential energy (PE)} = m g h$$

- Where m is mass, g is the acceleration due to gravity and h is height.

CALCULATION:

Given that :

- Height = 16cm, time (t) = 10s, Mass (m) = 50 kg, g = 10 m/s²
- Total Height (h) = 40 × 16 = 640 cm = **6.4 m**

$$\Rightarrow \text{Potential energy (PE)} = m g h = 50 \times 10 \times 6.4 = 3200 \text{ J}$$

$$\Rightarrow \text{Work done (W)} = \text{PE} = 3200 \text{ J}$$

$$\Rightarrow \text{Power (P)} = \text{Work done (P)}/\text{Time (t)} = 3200/10 = 320 \text{ Watt}$$

26. Answer: a

Explanation:

Given:

$$P + R = 15 \text{ min}$$

$$P + Q = 12 \text{ min}$$

$$Q + R = 20 \text{ min}$$

Calculation:

LCM of 15, 12, 20 = 60 unit (assume the total quantity of the tank)

Working together can fill the tank in:

$$\text{Efficiency of } P + R = 60/15 = 4 \text{ units/min}$$

$$\text{Efficiency of } P + Q = 60/12 = 5 \text{ units/min}$$

$$\text{Efficiency of } Q + R = 60/20 = 3 \text{ units/min}$$

Efficiency of all three cistern when work together =

Adding all the three equation

$$2(P + Q + R) = 12$$

$$P + Q + R = 6$$

Total work can be completed in $60/6 = 10$ mins

27. Answer: b

Explanation:

The correct answer is Option 2, i.e. 10 ohm.

- Given that two resistors of 20 ohms are connected in parallel.
- So, the resultant resistance
- $1/R_c = 1/R_1 + 1/R_2 = 1/20 + 1/20 = 1/10$ ohm
- So, $R_c = 10$ ohm
- A voltage source offers very minimal resistance. Hence, the total resistance is 10 ohms.

28. Answer: b

Explanation:

Concept:

Speed and time are inversely proportional to each other.

So when speed increases time will decrease and when time will increase speed will decrease.

Given:

Person walk to its 80% usual speed.

Let usual speed = 5 units then new speed = 4 units

As we know time is inversely proportional to speed

Usual time = 4 units and new time = 5 units

According to question:

	Usual	New
Speed	5	4
Time	4	5

Difference between time is given is 18 mins

Calculation:

So new time – usual time = difference in time

$\therefore 1 \text{ unit} = 18 \text{ mins}$

Usual time = $18 \times 4 = 72 \text{ mins}$

29. **Answer: c**

Explanation:

The minimum number of lines required to make the given image is shown below:

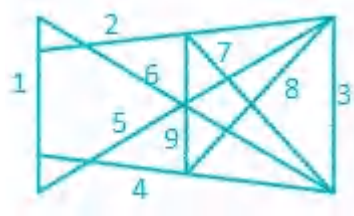

Hence, '9' is the correct answer.

30. **Answer: a**

Explanation:

Explanation:

First angle projection	Third-angle projection
Object is kept in the first quadrant	An object is assumed to be kept in the third quadrant
Object lies between the observer and the plane of the projection	A plane of projection lies between the observer and the object
The plane of projection is assumed to be Non-transparent	The plane of projection is assumed to be transparent.
Front (elevation) view is drawn above the XY line	Front (elevation) view is drawn below the XY line
Top (plan) view is drawn below the XY line	Top (plan) view is drawn above the XY line
Left view is projected on the right plane and vice versa	Left view is projected on the left plane itself
Followed in India, European countries	Followed in the USA

Projection	Symbol
First angle	
Third angle	

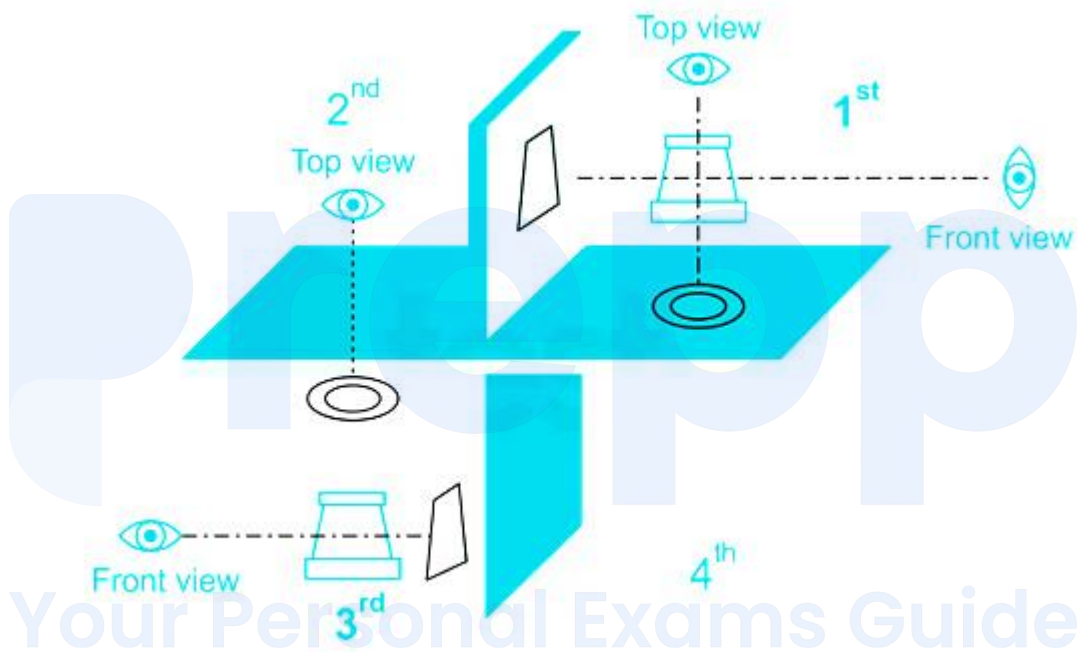

31. Answer: d

Explanation:

Given:

Profit % = 25%

Cost Price = Rs. 18000

Formula:

Profit = Cost Price - Selling Price

Concept:

Profit is always calculate on cost price.

Calculation:

$$25\% \text{ of } 18000 = (25/100) \times 18000 = \text{Rs. } 4500$$

$$\text{Add this profit percentage value in cost price} = 18000 + 4500 = \text{Rs. } 22500$$

32. Answer: d

Explanation:

The pattern is:

T	T	T	T	T	T	O
T	T	T	T	T	O	T
T	T	T	T	O	T	T
T	T	T	O	T	T	T
T	T	O	T	T	T	T

'O' is shifting to the left end as we move along the series.

Hence, 'TTOTTTT' is the correct answer.

33. Answer: d

Explanation:

CONCEPT:

- Power : The rate of work done by an electric current is called power. It is denoted by P. The SI unit of power is the watt (W).

Power dissipation is given by:

$$\text{Power (P)} = V I = V^2/R = I^2 R$$

Where V is the potential difference across resistance, I is current flowing and R is resistance.

CALCULATION:

Given that:

$$\text{Resistance (R)} = 5 \Omega$$

$$\text{Current (I)} = 2 \text{ A}$$

$$\text{Power (P)} = I^2 R = 2^2 \times 5 = 20 \text{ W}$$

34. Answer: a

Explanation:

Let us consider that all of them are facing each other.

The arrangement will be as shown below:

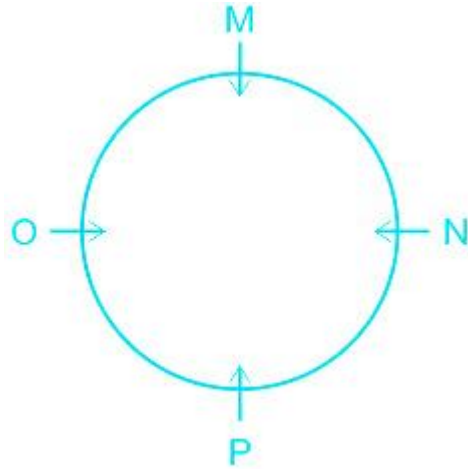

1) O is to the right of P → False (as, O is to the left of P)

2) M is facing P → True

3) M is to the right of N → True

4) O is facing N → True

Hence, 'O is to the right of P' is false.

35. Answer: c

Explanation:

Concept:

Black body :

- It is an **idealized physical body that absorbs all incident electromagnetic radiation, regardless of frequency or angle of incidence.**
- The name "black body" is given because it absorbs all colors of light.
- **A black body also emits black-body radiation.**
- The blackbodies are used for lighting, heating, security, thermal imaging, as well as testing and measurement applications.
- Since the intensity of the energy at any temperature and wavelength can be determined using the Planck Law of radiation.

Explanation:

- Black & rough surface absorbs more heat than any other surface under identical conditions.
- The black surface absorbs all the radiations more easily than any surface as its absorptivity is 1.

36. Answer: a

Explanation:

The correct answer is Option 1, i.e Tamil Nadu.

★ Key Points

- **Pongal** is primarily celebrated in the Tamil Nadu state of India
- It is also referred to as **Thai Pongal**.
- It marks the **end of Winter solstice**.
- It is **dedicated** to the **Hindu Sun God**.
- The **first day of Pongal** is known as **Bhogi** .

37. Answer: c

Explanation:

Let the number be X and Y

According to question

$$X = (9/7 \times Y)$$

$$\Rightarrow X : Y = 9 : 7$$

Total number is 16 units

$$16 \text{ units} = 800$$

Your Personal Exams Guide

$$\Rightarrow 1 \text{ unit} = 800/16 = 50$$

$$\Rightarrow \text{Larger part} = 9 \text{ units} = 9 \times 50 = 450.$$

38. Answer: c

Explanation:

The correct answer is M.N Roy.

★ Key Points

- The idea of Constituent Assembly was given by Manabendra Nath Roy or M.N.Roy
- In **1934** , M.N.Roy put forth the **idea of the Constituent Assembly** .
- The constituent assembly was formed in 1946 on the basis of the cabinet mission plan.
- Temporary Chairman - Dr. Sachchidananda Sinha.
- Permanent Chairman - Dr. Rajendra Prasad
- Vice Chairman - Harendra Kumar Mukherjee
- Constitutional adviser - B.N Basu
- **Dr. B.R Ambedkar** was the **head of the Drafting Committee** .
- **Constitution was adopted** by Constituent Assembly on **26 November 1949** .
- It became **effective** on **26 January 1950** .

★ Additional Information

- The Indian Constituent Assembly represented fully representative of the States and Provinces in India.
- Initially, the number of members was 389 , after the partition 299 members left.
- Out of this 299, 229 were from the British provinces and 70 were nominated from the princely states.
- It aimed at providing opportunities to each and every community.
- Representatives from princely states and British Indians were also a part of it.

39. Answer: a

Explanation:

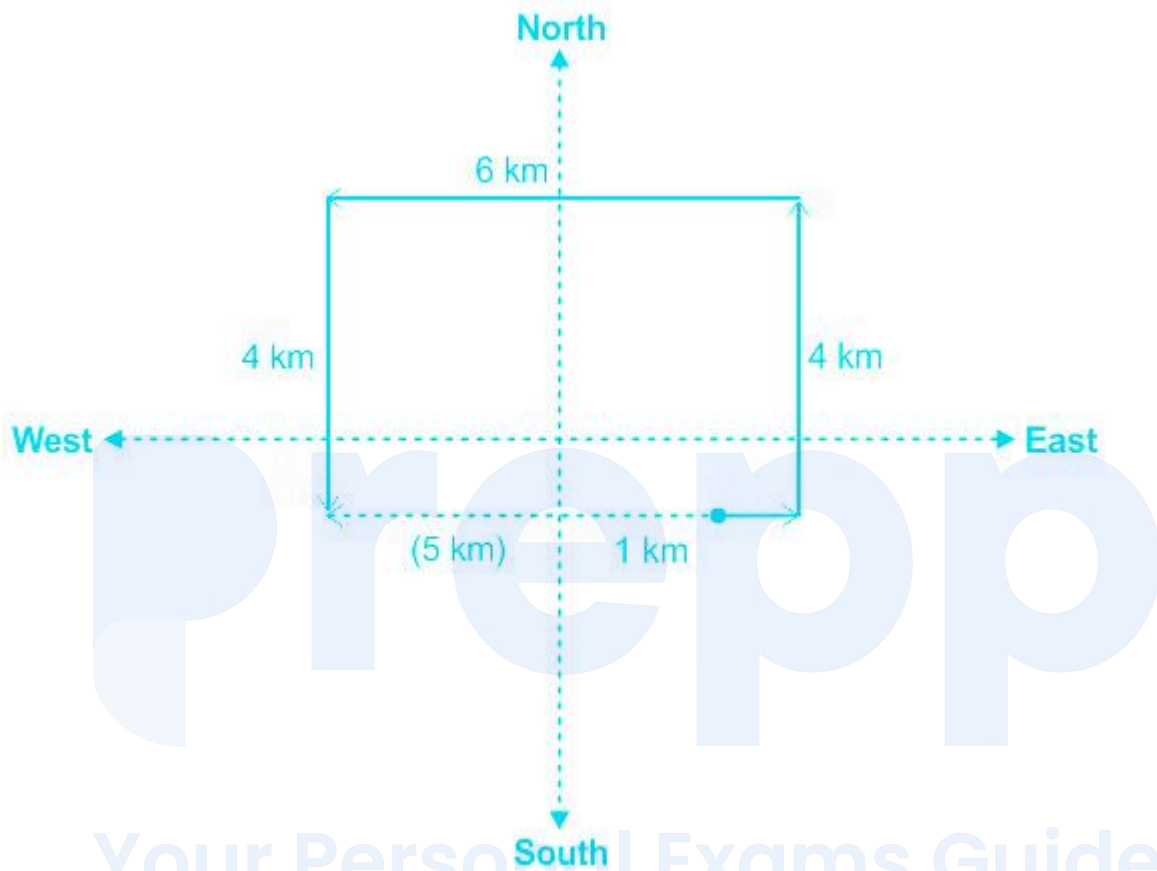

Hence, he is 5 km to the west from his reference position.

40. Answer: d

Explanation:

Concept:

HCF = Highest common factor.

Factor of 275 = $5^2 \times 11$

Factor of 308 = $4 \times 7 \times 11$

Common factor = 11

41. Answer: c

Explanation:

Given:

Speed is given in km/sec and we have to convert it into m/sec

Concept:

To convert speed from km/s into m/sec:

Multiply given speed by $5/18$

To convert speed from m/sec into km/sec:

Multiply given speed by $18/5$

Distance = Speed \times Time

Calculation:

$$72 \times 5/18 = 20\text{m/sec}$$

Distance = Speed \times Time

$$= 20 \times 5 = 100 \text{ meter}$$

\therefore Distance is 100 m

42. Answer: d

Explanation:

CONCEPT:

- Resistance : The measurement of the opposition of the flow of electric current through a conductor is called resistance of that conductor. It is denoted by R.

There are mainly two ways of the combination of resistances:

- **Resistances in series combination** : When two or more resistances are connected one after another such that the same current flows through them are called as resistances in series.



The net resistance/equivalent resistance (R) of resistances in series is given by:

Equivalent resistance, $R = R_1 + R_2$

- **Resistances in parallel combination** : When the terminals of two or more resistances are connected at the same two points and the potential difference across them is equal is called resistances in parallel.

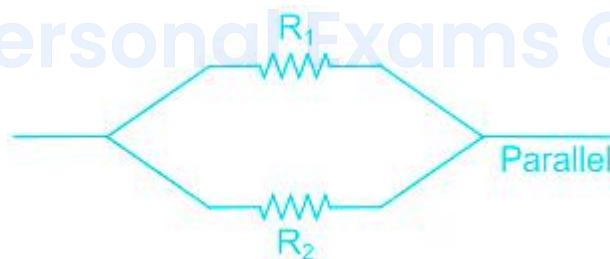

The net resistance/equivalent resistance (R) of resistances in parallel is given by:

$$\frac{1}{R} = \frac{1}{R_1} + \frac{1}{R_2}$$

- Ohm's law: At constant temperature and other physical quantities, the potential difference across a current-carrying wire is directly proportional to the current flowing through it.

$$V = R I$$

Where V is the potential difference, R is resistance and I is current.

CALCULATION:

Given that:

$$R_1 = 10 \Omega \text{ and } R_2 = 15 \Omega$$

$$\text{Resistance in series } (R') = 24 \Omega$$

$$\text{Potential difference } (V) = 12 \text{ V}$$

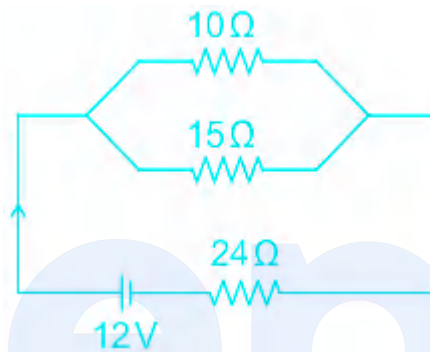

The **net Resistance in Parallel combination** is given by:

$$1/R = 1/R_1 + 1/R_2$$

$$1/R = 1/10 + 1/15$$

$$\text{So } 1/R = 5/30$$

$$\text{Hence } R = 6 \Omega$$

The combination is connected in series with a 24Ω resistor, so the new net resistance of the circuit will be:

$$\text{New Total Resistance} = 6 + 24 = 30 \Omega$$

Use Ohm's law:

$$\text{Electric current } (I) = V/R = 12/30 = 0.4 \text{ A}$$

$$\text{Now, Potential across } 24 \Omega \text{ resistor} = 24 \times 0.4 = 9.6 \text{ V}$$

Now, Potential across Parallel combination = $12 - 9.6 = 2.4 \text{ V}$

This is the electric Potential that will Reach both the Resistances of 15Ω and 10Ω .

By Using Ohm's law:

$$V = I \times R$$

$$2.4 = I \times 15$$

Electric current (I) = 0.16A. So option 4 is correct.

43. Answer: c

Explanation:

The Correct Answer is Option 3 i.e Relative permeability.

- Relative Permeability does not have any dimensions.
- Relative permeability is the ratio of effective permeability of a particular fluid at a particular saturation to absolute permeability of that fluid at total saturation.
- Frequency is the number of waves that pass a fixed place in a given time.
- Volume is the amount of space something takes.
- The Force is a Pull or Push upon an object that causes it to change velocity.
- Force has both **magnitude and direction**.

44. Answer: d

Explanation:

The least possible venn diagram is:

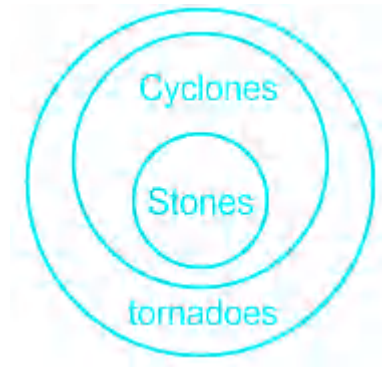

Conclusion I: Some tornadoes are stones → True (It is definite)

Conclusion II: Some cyclones are stones → True (It is definite)

Hence, both I and II follow.

45. Answer: b

Explanation:

Concept:

Thermal Conductivity:

- Thermal conductivity refers to the ability of a given material to conduct/transfer heat.
- It is generally denoted by the symbol 'k' but can also be denoted by 'λ' and 'κ'.
- The reciprocal of this quantity is known as thermal resistivity.
- Materials with high thermal conductivity are used in heat sinks whereas materials with low values of λ are used as thermal insulators.
- The law of heat conduction states **that the rate at which heat is transferred through a material is proportional to the negative of the temperature gradient and is also proportional to the area through which the heat flows.**
- The differential form of this law can be expressed through the following equation: $q = -k \Delta T$, where k = thermal conductivity, ΔT = temperature gradient, q = heat flux

Explanation:

- The thermal conductivity of the copper is 385.0 W/mK.
 - The thermal conductivity of mercury is 7.9 W/mK.
 - The thermal conductivity of Aluminium is 205 W/mK.
 - The thermal conductivity of Silver is 419 W/mK.
 - **Hence, from the above data, the thermal conductivity of mercury is the lowest.**
-

46. Answer: d

Explanation:

In all the figures except '4' the number of small boxes inside the figure is 10, while in figure 4, there is only 9 small boxes inside the figure.

Hence, 'option 4' is the odd one out.

47. Answer: b

Explanation:

prepp
Your Personal Exams Guide



Hence, H is 5 km to the North of G.

48. Answer: c

Explanation:

Concept:

Non-metal:

- Non-metals are the elements that form negative ions by accepting or gaining electrons.
- Non-metals usually have 4, 5, 6 or 7 electrons in their outermost shell.
- Non-metals are those which lack all the metallic attributes. They are good insulators of heat and electricity.
- They are mostly gases and sometimes liquid.

- Some of them are even solid at room temperatures like Carbon, sulphur and phosphorus.

Thermal Conductivity:

- Thermal conductivity refers to the ability of a given material to conduct/transfer heat.
- It is generally denoted by the symbol 'k' but can also be denoted by 'λ' and 'κ'.
- The reciprocal of this quantity is known as thermal resistivity.
- Materials with high thermal conductivity are used in heat sinks whereas materials with low values of λ are used as thermal insulators.
- The law of heat conduction states **that the rate at which heat is transferred through a material is proportional to the negative of the temperature gradient and is also proportional to the area through which the heat flows.**
- The differential form of this law can be expressed through the following equation: $q = -k \Delta T$, where k = thermal conductivity, ΔT = temperature gradient, q = heat flux

Explanation:

- The thermal conductivity of wood is generally within the range of 0.1–0.2 W/mK.
- The thermal conductivity of water is 0.598 W/m·K at 20°C.
- **The thermal conductivities of the ice samples prepared by the 0% CAS and 50% CAS air-blast freezing methods measured at -29°C are both 2.75 ± 0.03 W/(m·K).**
- Bricks possess a low thermal conductivity which averages between 0.5 – 1.0 W/(m/K).
- Hence, the ice has a higher thermal conductivity.

49. **Answer: a**

Explanation:

The logic is:

Alphabets	A	B	C	D	E	F	G	H	I	J	K	L	M
Positional value	1	2	3	4	5	6	7	8	9	10	11	12	13
Positional value	26	25	24	23	22	21	20	19	18	17	16	15	14
Alphabets	Z	Y	X	W	V	U	T	S	R	Q	P	O	N

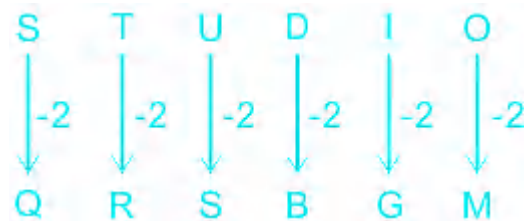

Similarly,



Hence, 'PYU' is the correct answer.

50. Answer: d

Explanation: **Your Personal Exams Guide**

Given:

Total distance $7.5 = 75/10 = 15/2$

In the morning he travels $= 25/6$

Calculation:

Remaining distance = Total distance – distance travelled in the morning

$15/2 - 25/6 = 20/6$

$\therefore 10/3$

51. Answer: d

Explanation:

5 year ago, the ratio of their ages was 6 : 1.

Let their ages be measured in terms of unit x.

So, presents age of father is $6x + 5$ and present age of son is $x + 5$.

The sum of the present ages of a father and a son is 45 year.

According to problem:

$$(6x + 5) + (x + 5) = 45$$

$$\Rightarrow 6x + 5 + x + 5 = 45$$

$$\Rightarrow 7x = 45 - 10$$

$$\Rightarrow 7x = 35$$

$$\Rightarrow x = 5$$

So, the present age of father is $6x + 5$ i.e, $(6 \times 5) + 5 = 35$ years.

Hence, '35 year' is the correct answer.

52. Answer: a

Explanation:

The set of letters which represents actors who are writers lies in the intersection of rectangle and triangle, as shown below:

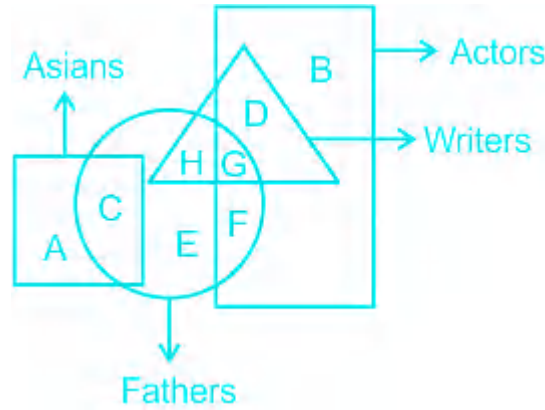

Hence, 'GD' is the correct answer.

53. Answer: a

Explanation:

The least possible venn diagram is:



Conclusion I: Some grass are bamboo. → True (It is definite)

Conclusion II: Some tall are bamboo. → True (It is definite)

Conclusion III: Some grass are tall. → True (It is definite)

Hence, all conclusions I, II and III follow.

54. Answer: c

Explanation:

The correct answer is Option 3, i.e. Hard Rubber.

- Hard rubber is the insulator having high Resistivity.
- An **insulator** is a material that **does not conduct electric current**.
- Rubber, **Glass**, Oil, Dry Wood are some of the examples of Insulator.
- A **conductor** is a material that **allows the flow of Electric Current**.
- Silver, Copper, Gold, Iron are some of the examples of Conductor.
- **Diamond** is a good conductor of heat because of the strong covalent bonding and low phonon scattering.

55. Answer: d

Explanation:

CONCEPT:

- The rate of change of displacement of an object is **velocity**.
- The rate of change of velocity of an object is acceleration.
- **Equations of motion** describe the behavior of a physical system in terms of 'its motion as a function of time'.
- If an object is moving with constant acceleration 'a', initial velocity 'u', the first equation of motion gives the final velocity 'v' after a time 't'

$$v = u + at$$

CALCULATION:

Given, $a = 5 \text{ m/s}^2$, time = 5 s.

Since the object started from rest, so $u = 0$.

According to the **first equation of motion**

$$v = u + at = 0 + 5 \times 5 = 25 \text{ metre/sec}$$

so The correct answer is option 4 i.e. 25 m/s

★ Mistake Points

- In the first equation of motion, $v = u + at$, keep in mind that the value of **acceleration is constant**. If acceleration is not constant, we can not use this equation.

56. Answer: b

Explanation:

Given:

Distance = 2000 m

Speed of Train 1 = 20 m/s

Speed of Train 2 = 30 m/s

Formula used:

Relative speed: Speed of train1 + Speed of train2

Distance = Speed \times time

Concept used:

(when two trains are running towards each other, then the speed of both the trains were added.

When two trains are running opposite to each other, then the speed of both the trains were subtracted)

\therefore Relative speed = $30 + 20 = 50\text{m/sec}$

According to the question,

$2000 = \text{Time} \times 50$

\therefore Required Time = 40 sec

57. Answer: d

Explanation:

Formula:

Average speed = total distance / total time

Calculation:

In 1st phase

Distance = 30 meters

Time = 5 sec

In 2nd phase

Distance = 30 meters

Time = 3 sec

From both the cases total distance = 60 meters

Total Time = 8 sec

Average speed = $60 / 8 = 7.5$ m/sec

58. Answer: b

Explanation:

Given:

$$(423)^{423} \times (1237)^{28}$$

Concept:

Consider only last digit

In 423 last digit is 3

In 1237 last digit is 7

Powers given is 423 and 28

We have to divide powers by 4 (by rule of cyclicity)

$$423/4 = \text{Remainder } 3$$

$$28/7 = \text{Remainder } 0 \text{ or } 4$$

Now put these values over last digits of the main question what we have mention above

$$3^3 \times 7^4$$

$$\Rightarrow 7 \times 1 = 7$$

59. Answer: c

Explanation:

The correct answer is Option 3, i.e. 9H.

- 9H has the hardest graphite lead.
- The letter "H" is used to indicate the **hardness** of a pencil's mark.
- The letter "B" is used to indicate the **blackness** of a pencil's mark (a darker mark means a softer lead).
- The **Higher the number** next to the 'H', **harder** the pencil lead.
- The Higher the number next to the 'B', softer the pencil lead.
- Pencil Lead is a mixture of graphite and clay.

60. Answer: a

Explanation:

Explanation:

- A lever is a simple machine consisting of a beam or rigid rod pivoted at a fixed hinge, or fulcrum, used to transfer a force to a load and usually to provide a mechanical advantage.
- On the basis of the locations of fulcrum, load, and effort, the lever is divided into three types.

First Class Lever

- First-class levers have the fulcrum between the force and the load.
- Effort and the load moves in opposite direction.
- Examples : See-saw, crowbar, scissors, claw and hammers, the handle of water pump, a beam balance, wire cutter, plier, etc.

Second-class lever

- In second-class levers, the load is between the effort (force) and the fulcrum.
- **Effort and the load moves in the same direction.**
- Examples : Wheelbarrow, Staplers, Bottle openers, Nutcrackers and Nail clippers.

Third-class lever

- In third-class levers, the effort is between the load and the fulcrum.
- Effort and the load moves in the same direction.
- Examples : Fishing rod, Broom, Baseball bat, Bow and Arrow Human jaw.

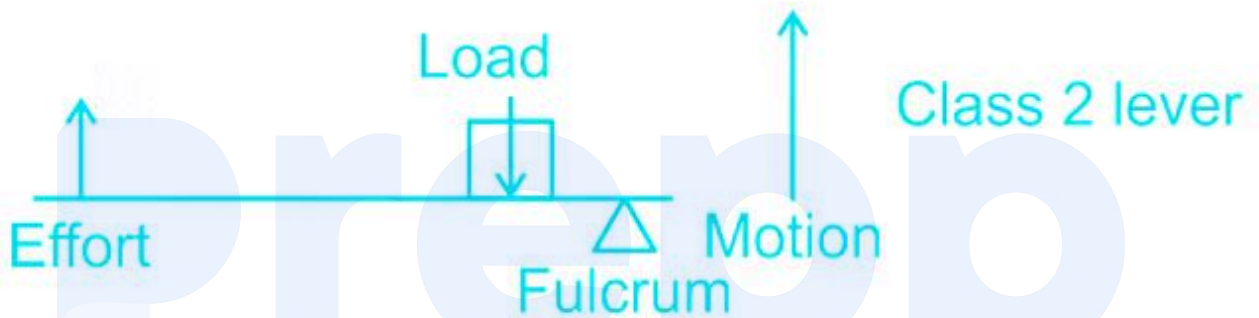
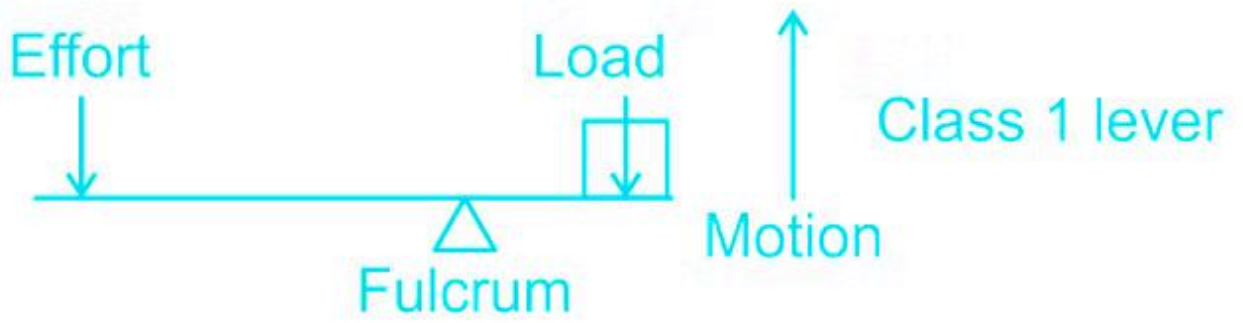

61. Answer: d

Explanation:

Concept:

Specific heat or specific heat capacity of a body:

- The amount of heat energy required to raise the temperature of a unit mass of a body through 1° C (or K) is called the specific heat of the material of the body.
- It is generally denoted by C.

$$\Rightarrow Q = mc\Delta T$$

Where Q = heat required, ΔT = change in temperature and m = mass of the body.

Calculation :

Given:

mass of oil, m = 100 g, the specific heat of oil, c = 1965 Jkg⁻¹ K⁻¹ , Temp difference = 20°C

$$Q = mc\Delta T$$

Heat transfer,

$$Q = 0.1 \times 1965 \times 20$$

$$Q = 3930 \text{ J} = 3.93 \text{ kJ}$$

Thus, option (4) is correct answer.

Your Personal Exams Guide

62. Answer: a

Explanation:

5 1 2 → steel makes tower
1 7 5 → brick makes tower
3 2 7 → brick and steel

Hence, '3' is the code for 'and'.

63. Answer: a

Explanation:

All options except 'carrom board' are circular in shape, while 'carrom board' is square in shape.

Hence, 'carrom board' is the correct answer.

64. Answer: a

Explanation:

The correct answer is Option 1, i.e. Circle.

- A **compass** is a technical drawing instrument that can be used for inscribing circles or arcs.
 - A **circle** is the set of points in a plane that are equidistant from a given point.
 - A **rectangle** has 4 angles, each measuring 90° .
 - A **triangle** is a polygon with three edges and three vertices.
-

Your Personal Exams Guide

65. Answer: c

Explanation:

G is		
+	-	*
Daughter	Father-in-law	Husband
to H		

Symbol in Diagram	Meaning
○	Female
□	Male
==	Married Couple
—	Siblings
	Difference of A Generation

1) $O * N - M + L \rightarrow$ O is husband of N, N is father-in-law of M, M is daughter of L.

As O is husband of N, it means N is wife of O, so O cannot be female and hence not sister L

2) $O - N * M + L \rightarrow$ O is father-in-law of N, N is husband of M, M is daughter of L.

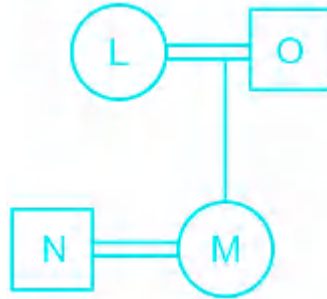

O is husband of L.

3) $O + M - N * L \rightarrow$ O is daughter of M, M is father-in-law of N, N is husband of L.

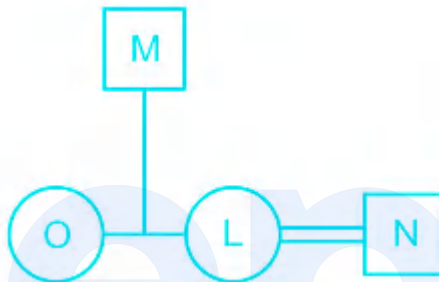

O is sister of L.

4) $O - N + M * L \rightarrow$ O is father-in-law of N, N is daughter of M, M is husband of L.

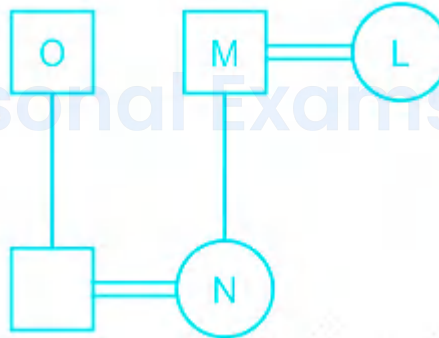

O is in-law of L.

Hence, 'O + M - N * L' is the correct answer.

66. Answer: c

Explanation:

Concept:

When any sum is invested in compound interest we can calculate the successive rate of the give rate.

Formula:

Successive percentage: $\{a + b + (a \times b / 100)\}$

Total amount = principal + interest earned

Calculation:

Successive percentage of 20% for 2 years that is: 44%

Now calculate 44% of 10000

$$(44 / 100) \times 10000 = \text{Rs. } 4400$$

4400 is interest he earned at the end of two years

Total amount = principal + interest earned

$$10000 + 4400 = \text{Rs. } 14400$$

67. Answer: b

Explanation:

Given:

Efficiency of Pipe A = $30 \text{ m}^3/\text{hr}$

Efficiency of Pipe B = $40 \text{ m}^3/\text{hr}$

Formula:

Volume of the tank = Volume filled in one hour \times total time taken to fill the tank

Calculation:

When both work together, total efficiency = $30 + 40 = 70 \text{ m}^3/\text{hr}$

\therefore Volume of the tank = $70 \times 4 = 280 \text{ m}^3$

68. Answer: c

Explanation:

Given:

The total surface area of cube = 96 cm^2

Formula Used:

Total surface of cube = $6(\text{side})^2$

Calculation:

According to the question

$$6 \times (\text{side})^2 = 96$$

$$\Rightarrow (\text{side})^2 = 96/6$$

$$\Rightarrow (\text{side})^2 = 16 \text{ cm}$$

$$\Rightarrow \text{Side} = 4 \text{ cm}$$

\therefore The side of the square is 4 cm.

69. Answer: a

Explanation:

I) 120 person visited the zoo on that certain day.

Revenue cannot be calculated using this as the price of tickets is not known.

II) A discount of 25% on ticket price was offered on that certain day.

Revenue cannot be calculated using this as the price of tickets and number of persons who visited the zoo is not known.

Hence, neither statement I nor II is sufficient.

70. Answer: d

Explanation:

Concept:

Conduction:

- It is the process by which heat energy is transmitted through collisions between neighboring atoms or molecules.
- It occurs more readily in solids and liquids, where the particles are closer together than in gases, where particles are further apart.
- The rate of heat flow is the amount of heat that is transferred per unit of time in some material, usually measured in watts (joules per second).
- Formula, rate of heat flow, $\frac{Q}{t} = \frac{kA\Delta T}{a}$,
- Where, ΔT = difference in temperature, A = area, k = thermal conductivity, a = thickness of the conductor, Q = heat, t = time

Calculation:

Given,

Thickness, $a = 2 \text{ cm} = 0.02 \text{ m}$, Area, $A = 0.1 \text{ m}^2$, Temperature difference, $\Delta T = 30^\circ\text{C}$,

Thermal conductivity, $k = 0.01 \text{ J}/(\text{s m K})$

The rate of heat flow through the sheet can be calculated as,

$$\frac{Q}{t} = \frac{kA\Delta T}{a}$$

$$\frac{Q}{t} = \frac{0.01 \times 0.1 \times 30}{0.02}$$

$$\frac{Q}{t} = 1.5 \text{ J/s}$$

71. Answer: d

Explanation:

The correct answer is Option 4, i.e 0.

- When a body is projected vertically upward **final velocity will be zero.**
- **Momentum = mass × velocity.**
- Mass, m = 200 g, Velocity, V = 0.
- Momentum = 200 × 0 = 0

72. Answer: c

Explanation:

(Implicit - suggested though not directly expressed)

Assumption I: Not all college students want a job.

It is neither mentioned, nor suggested in the statement.

Assumption II: There are enough summer jobs for most college students.

It is neither mentioned, nor suggested in the statement.

Hence, neither I nor II is implicit.

73. Answer: b

Explanation:

Concept:

Total sum of the ratio = $3 + 2 + 5 = 10$

Total profit is 8 units

10 units = Rs.1000

1unit = $1000/10 = \text{Rs. } 100$

Share of A in units = 3 unit

So $100 \times 3 = \text{Rs.}300$

74. Answer: d

Explanation:

Explanation:

On the basis of the position of load, effort, and fulcrum, the lever can be classified into three types.

First-class lever:

- The lever in which the fulcrum is located in between the load and the effort is called a first-class or class one lever.
- **Examples** : a pair of scissors, a see-saw, and a crowbar.

Second-class lever:

- A Lever in which the load is located between the fulcrum and the effort is called a second-class or class two lever.
- **Examples** : a wheelbarrow, a bottle opener, and a nutcracker.

Third-class lever:

- It is a Lever in which the effort is located in between the fulcrum and the load is called a third-class or class three lever.
- **Examples** : a stapler, a pair of tongs, and a finishing rod.

Levers of the first order

- Usually in a first-order lever, the length of the effort arm is greater than that of the load arm.
- Thus, the mechanical advantage of a first-order lever, in general, is greater than or equal to one.
- But in scissors, the effort arm is shorter than the load arm, and the mechanical advantage is less than one.
- **Therefore, If we compare the effort arm length with the load arm length in a class 1 lever, effort arm length can be greater than, equal to or less than the length of the load arm**

75. **Answer: c**

Explanation:

The correct answer is decreases, increases.

★ Key Points

- Increasing the pressure on an object decreases the volume of the object and therefore increases its density.
- This works according to **Boyle's Law** .
- At a **constant temperature**, the **pressure** of a given mass of an ideal gas is **inversely proportional** to its **volume** .
- The formula is given by $P_1 V_1 = P_2 V_2$

76. **Answer: c**

Explanation:

Explanation:

On the basis of the position of load, effort, and fulcrum, the lever can be classified into three types.

First-class lever:

- The lever in which the fulcrum is located in between the load and the effort is called a first-class or class one lever.
- Examples: a pair of scissors, a see-saw, and a crowbar.

Second-class lever:

- A Lever in which the load is located between the fulcrum and the effort is called a second-class or class two lever.
- Examples: a wheelbarrow, a bottle opener, and a nutcracker.

Third-class lever:

- It is a Lever in which the effort is located in between the fulcrum and the load is called a third-class or class three lever.
- Examples: a stapler, a pair of tongs, and a finishing rod.

Levers of the Second Order

- **In a second-order lever, the effort arm is greater than the load arm.**
- Hence, the mechanical advantage of a second-order lever is always greater than one.

77. Answer: a

Explanation:

CONCEPT:

- Power : The rate of work done by an electric current is called power. It is denoted by P. The SI unit of power is the watt (W).

Power dissipation is given by:

$$\text{Power (P)} = V I = V^2/R = I^2 R$$

Where V is the potential difference across resistance, I is current flowing and R is resistance.

- Voltage (V) is the amount of **potential difference between two points**.

EXPLANATION:

From the above formula of the power, option 1 is correct.

78. Answer: d

Explanation:

CONCEPT:

- Resistance : The property of any conductor that opposes the flow of electric current through it is called resistance.
- It is denoted by R and the SI unit is the ohm (Ω).

The resistance is given by:

$$R = \rho L/A$$

where ρ is resistivity, L is the length and A is the area of the cross-section.

EXPLANATION:

Since $R = \rho L/A$

If L becomes 2L, then R becomes 2R.

$$R = \rho \times 2L/A$$

$$\text{So, } R = 2R'$$

- If we **double the length of copper wire, its resistance increases twotimes** . So option 4 is correct.

79. Answer: d

Explanation:

The correct answer is Option 4, i.e Deepshikha.

- Deepshikha is NOT written by Premchand .
- Soz-e-Watan was his **first collection** of five short stories in the book.
- Godaan, Karmabhoomi, Gaban, Mansarovar, Nirmla are some of his Novels.
- His **real name** was **Dhanpat Rai Shrivastav**.
- He is referred to as '**Upanyas Samrat**' .

80. Answer: c

Explanation:

The correct answer is Option 3.

- The Celsius temperature (t_C) and the Fahrenheit temperature (t_F) are related as $t_F = (9/5) t_C + 32$.
- When the **temperature in Celsius scale increases** , it's equivalent **Fahrenheit temperature** will also be **high** .
- Fahrenheit scale is upscaled by taking **32°F as a freezing point** of water and **212°F as a boiling point of water**.
- The temperature of -40 degrees both the Celsius and Fahrenheit scales are the same.

81. Answer: d

Explanation:

Concept:

In these types of questions, we have to start pair 2 digits from the last

Calculation:

Square of 15 = 225

∴ Square root of 225 = 15

Now start pair 2 digits from the last.

3 such pairs are forming therefore there will be 3 digits after decimal.

82. Answer: a

Explanation:

Concept:

When two triangle are similar there perimeter is in the ratio of there sides

And area in the ratio of square of their side.

Calculation

According to question:

$$15/DE = 5/4$$

$$DE = 12 \text{ cm}$$

83. Answer: a

Explanation:

The correct answer is Option 1, i.e Sri Lanka.

- India beat Sri Lanka to win the Under19 Cricket Asia Cup 2018 .
- It was hosted by Bangladesh .

- **Yashasvi Jaiswal** was titled **Player of Series**.
 - India colts produced a clinical performance to outclass Sri Lanka by 144 runs in the final.
 - **India won the Tournament** for the **Sixth Time**.
 - Its was administered by Asian Cricket Council.
-

84. Answer: c

Explanation:

Explanation:

Front view:

- The view of the object formed on the vertical plane (VP) or frontal plane, when looked orthogonally at the object in the direction marked FRONT, is called front view.
- Here, the VP is behind the object.
- Thus, the object is in between the plane of projection and the eye.

Top view:

- The view of the object formed on the horizontal plane (HP) when looked orthogonally at the object from the top in the direction marked TOP, is called top view.
- Here, the horizontal plane is below the object.
- Thus, the object is in between the plane of projection and the eye.

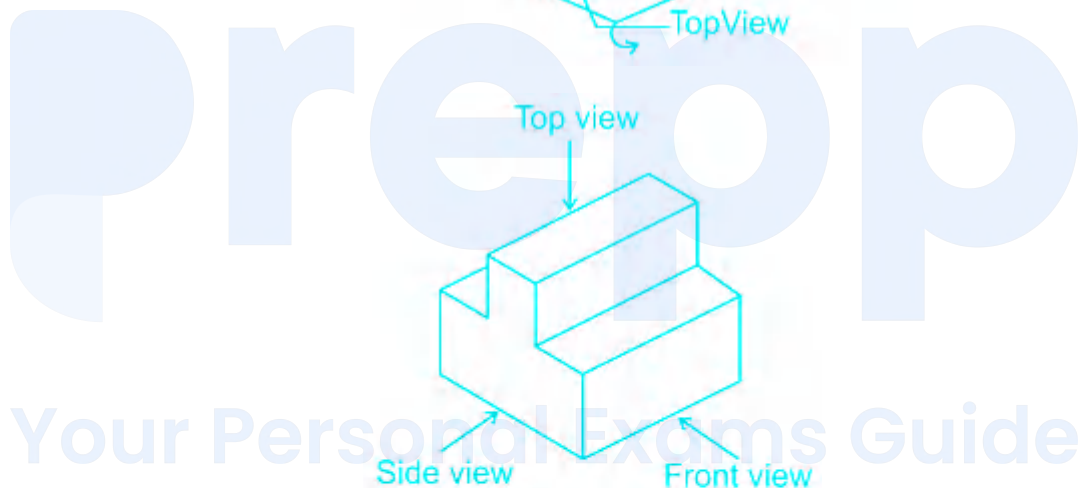
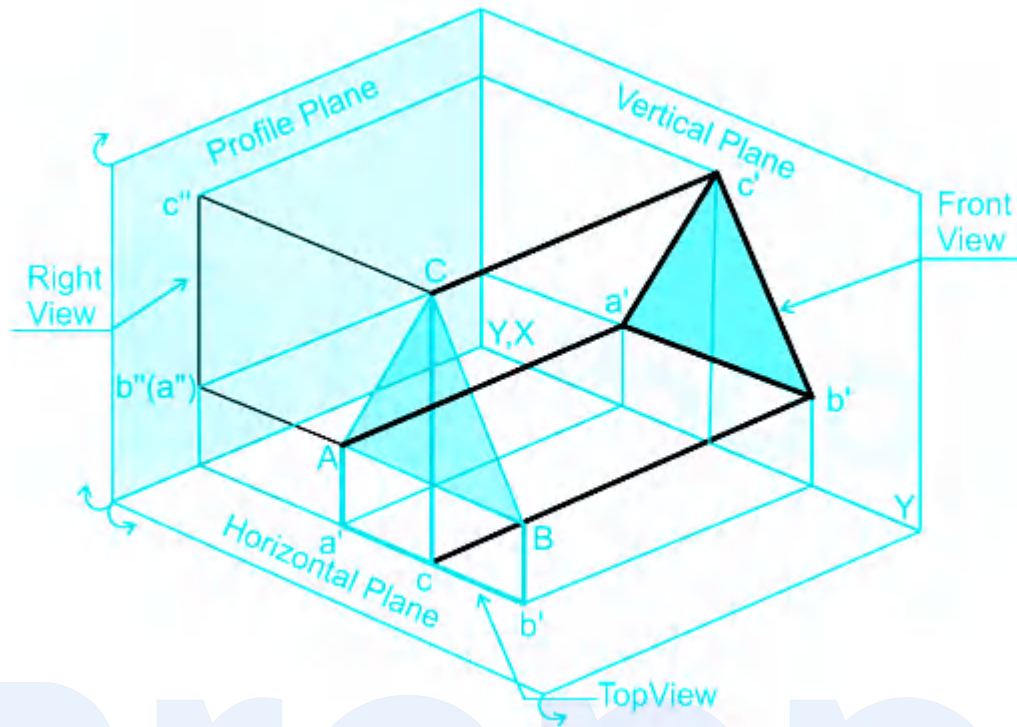

85. Answer: b

Explanation:

The correct answer is Option 2, i.e. Mr. Ranjan Gogoi.

- Mr. Ranjan Gogoi was appointed as the Chief Justice of India on **03.10.2018**.
- He served as the **46th Chief Justice of India**.
- Chief Justice of India is **appointed by the President**.
- The CJI comes under **article 124**.
- His tenure is **6 years or 65 years** whichever is earlier.
- The present CJI is Justice **Sharad Arvind Bobde**, and is the 47th CJI since 26 January 1950.

86. Answer: c

Explanation:

Concept:

Specific heat capacity:

- It can be defined as **the amount of heat required to change its temperature by one degree**.
- Mathematically, heat required, $Q = mc\Delta T$,
- where m = mass, c = specific heat capacity, ΔT = temperature difference
- The heat can be measured in Joule (J).

Explanation:

The heat required, $Q = mc\Delta T$

$$c = \frac{Q}{m\Delta T}$$

87. Answer: b

Explanation:

Follow BODMAS rule to solve this question, as per the order given below.

Step - 1: Parts of an equation enclosed in 'Brackets' must be solved first, and following BODMAS rule in the bracket -

Step - 2: Any mathematical 'Of' or 'Exponent' must be solved next.

Step - 3: Next, the parts of the equation that contain 'Division' and 'Multiplication' are calculated.

Step - 4: Last but not the least, the parts of the equation that contain 'Addition' and 'Subtraction' should be calculated.

Given expression is

$$10\% \text{ of } 1000\% \text{ of } 100 = ?$$

$$\Rightarrow (10/100) \times (1000/100) \times 100 = ?$$

$$\Rightarrow (100/100) \times 100 = ?$$

$$\therefore ? = 100$$

88. Answer: c

Explanation:

Explanation:

Levers are classified into three types or class based on the position of load and effort on the fulcrum

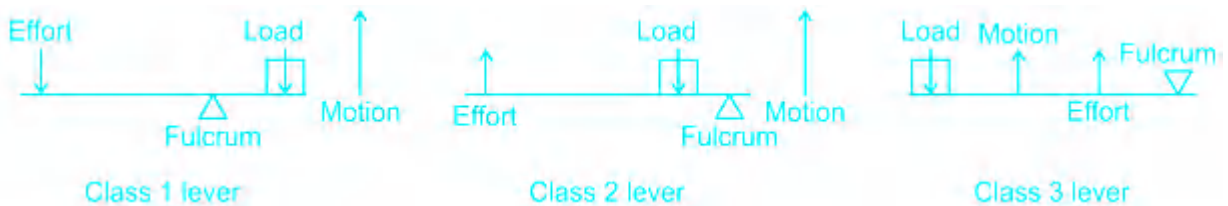

Class 1 Lever:

- A Class 1 lever has the fulcrum placed between the effort and load.
- The movement of the load is in the opposite direction of the movement of the effort.
- E.g. crowbars, scissors, pliers, tin snips, and seesaws
- **A pair of pliers and scissors are together considered as a double Class 1 lever.**

Class 2 Lever

- A Class 2 lever has the load between the effort and the fulcrum.
- In this type of lever, the movement of the load is in the same direction as that of the effort.
- E.g. nutcrackers, wheelbarrows, doors, and bottle openers

Class 3 lever

- A Class 3 lever has the effort between the load and the fulcrum.
- Both the effort and load are in the same direction.
- E.g. tweezers, arm hammers, and shovels.

89. Answer: a

Explanation:

The correct answer is Option 1, i.e. Plug-in.

- A component that adds to a software program's functionality is called as Plug-in.
- Plug-ins were first used in the **mid 1970s**.
- The idea of the plugin system was given by **Ryan Boren**.
- Plug-ins are made in **Wordpress**.
- **Processor** (CPU) is the logic circuitry that responds to and processes the basic instructions that drive a computer.
- **Modem** is short for "Modulator-Demodulator." It is a hardware component that allows a computer or another device, such as a router or switch, to connect to the Internet.

- **Server** is a computer or computer program which manages access to a centralized resource or service in a network

90. Answer: d

Explanation:

C is		
%	&	\$
Wife	Father	Daughter
to D		

$X \$ Y \% W \& Z \rightarrow$ X is daughter of Y, Y is wife of W, W is father of Z.

The family tree diagram is shown below:

Symbol in Diagram	Meaning
○	Female
□	Male
==	Married Couple
—	Siblings
	Difference of A Generation

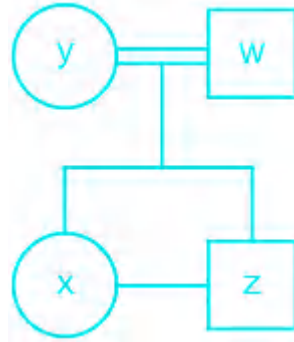

Hence, X is sister of Z.

Note: Given that "W has only one daughter". Hence, Z is definitely the son of W and not daughter of W.

91. Answer: c

Explanation:

The correct answer is Option 3, i.e. kWh.

- The energy consumption in electricity bills is expressed in units of kWh.
- A kilowatt-hour is a thousand watt-hours.
- 1 kWh is equal to 3.6×10^6 J kWh.
- Electricity was discovered by Benjamin Franklin .
- kVA is kilo-volt-ampere. kVA is a unit of apparent power, which is electrical power unit. 1 kilo-volt-ampere is equal to 1000 volt-ampere.
- kJ or Kilo Joule is a unit of Energy .

92. Answer: a

Explanation:

Concept:

length and breadth of a rectangle meet each other at 90°

Explanation:

By joining the diagonal, a right-angle triangle is made inside the rectangle.
Who's perpendicular = 6 cm, Base = 8 cm

Now, by Pythagoras theorem

$$(\text{Hypotenuse})^2 = (\text{Perpendicular})^2 + (\text{Base})^2$$

$$\text{Hypotenuse} = 10 \text{ cm}$$

Diagonal of rectangle is equal to the side of square.

$$\therefore \text{Side of square} = 10$$

$$\text{Area of square} = (\text{side})^2 = 100 \text{ cm}^2$$

Short trick:-

Pythagorean triplet: 6, 8, 10

Perpendicular = 6 cm, Base = 8 cm, Hypotenuse = 10 cm

Diagonal of rectangle = Base of square = 10 cm

$$\text{Area of square} = 10 \times 10 = 100 \text{ cm}^2$$

93. Answer: d

Your Personal Exams Guide

Explanation:

The logic is:



Hence, '12.6' is the correct answer.

94. Answer: c

Explanation:

Concept:

Arrange these in ascending order

2, 3, 3, 4, 5, 6, 7, 8, 9, 11

Total digits = 10

Add the centre most pair i.e. 5&6 and then divide by 2

Calculation:

$$5 + 6 = 11 / 2 = 5.5$$

95. **Answer: b**

Explanation:

Given:

Marked price = Rs. 1000

Discount = 16%

Profit = 5% (after condition)

Formula Used:

Selling Price = Cost Price + Profit

Calculation:

$$16\% \text{ of } 1000 = (16/100) \times 1000 = \text{Rs. } 160$$

Now if he sold the item at Rupees 160 less, then New Selling Price = Rs. 840

If Selling Price = Rs. 840, then profit = 5%

Let the Cost Price be Rs. X

According to the question,

$$(X + (5/100) \times X) = 840$$

$$\therefore X = \text{Rs. } 800$$

Short Trick:

From above, New Selling price = Rs. 840.

It includes 5% profit in it.

That means 105 units = Rs. 840

1 unit = Rs. 8

$$\therefore 100 \text{ unit} = \text{Rs. } 800$$

96. Answer: b

Explanation:

The logic is:

Alphabets	A	B	C	D	E	F	G	H	I	J	K	L	M
Positional value	1	2	3	4	5	6	7	8	9	10	11	12	13
Positional value	26	25	24	23	22	21	20	19	18	17	16	15	14
Alphabets	Z	Y	X	W	V	U	T	S	R	Q	P	O	N

1) JLN



2) MNO

$$M \xrightarrow{+1} N \xrightarrow{+1} O$$

3) RTV

$$R \xrightarrow{+2} T \xrightarrow{+2} V$$

4) CEG

$$C \xrightarrow{+2} E \xrightarrow{+2} G$$

Hence, 'MNO' is the odd one out.

97. Answer: b

Explanation:

Explanation:

- The spine is gently curved inward in the cervical area (neck) and the lumbar area (lower back).
- Another popular exercise for those who have to stand for long periods is called the pelvic Tilt.
- You will reduce the arch in your lower back, taking the pressure off that area.
- "Arching back" refers to exaggerating its natural curvature by pushing the chest and stomach forward and bottom out.

98. Answer: c

Explanation:

1) \div and $-$

Given expression: $15 \div 3 + 2 \times 10 - 6 = 14$

After replacing the symbols by their meaning, we get:

$$\text{L.H.S} = 15 - 3 + 2 \times 10 \div 6$$

$$= 15 - 2 + 3.33$$

$$= 18.33 - 2$$

$$= 16.33 \neq \text{R.H.S}$$

2) \div and $+$

$$\text{Given expression: } 15 \div 3 + 2 \times 10 - 6 = 14$$

After replacing the symbols by their meaning, we get:

$$\text{L.H.S} = 15 + 3 \div 2 \times 10 - 6$$

$$= 15 + 15 - 6$$

$$= 30 - 6$$

$$= 24 \neq \text{R.H.S}$$

3) $+$ and \times

$$\text{Given expression: } 15 \div 3 + 2 \times 10 - 6 = 14$$

After replacing the symbols by their meaning, we get:

$$\text{L.H.S} = 15 \div 3 \times 2 + 10 - 6$$

$$= 10 + 10 - 6$$

$$= 20 - 6$$

$$= 14 = \text{R.H.S}$$

4) $+$ and $-$

$$\text{Given expression: } 15 \div 3 + 2 \times 10 - 6 = 14$$

After replacing the symbols by their meaning, we get:

$$\text{L.H.S} = 15 \div 3 - 2 \times 10 + 6$$

$$= 5 - 20 + 6$$

$$= 11 - 20$$

$$= - 9 \neq \text{R.H.S}$$

Hence, '+' and 'x' is the correct answer.

99. Answer: c

Explanation:

The correct answer is Option 3, i.e. Tuba.

- Tuba is NOT a type of string musical instrument.
- **Tuba** is a **bass brass type of instrument**.
- Violin, Cello and Bass are string type instruments.

100. Answer: b

Explanation:

Month	Jan	Feb	Mar	Apr	May	Jun	Jul	Aug	Sep	Oct	Nov	Dec
Code	1	4	4	0	2	5	0	3	6	1	4	6

Date: January 26, 1989

Steps to find the day of the week:

Last two digit of year	89
No. of leap year (divisor)	$89 \div 4$ Divisor = 22
Code of the month	1
Date	26

Total = $(89 + 22 + 1 + 26) = 138$

And $138 \div 7$, we get 5 as remainder.



Your Personal Exams Guide

Code	Day
1	Sunday
2	Monday
3	Tuesday
4	Wednesday
5	Thursday
6	Friday
0	Saturday

'5' is the code for Thursday.

Hence, 'Thursday' is the correct answer.

101. Answer: d

Explanation:

Flat Ribbon Cable (FRC)

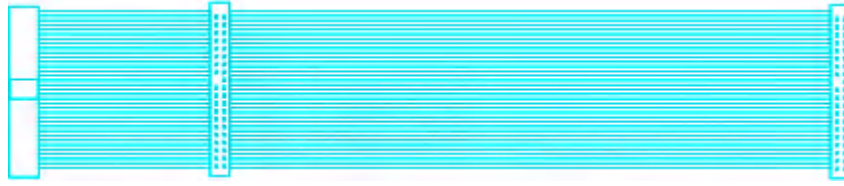

- FRC (Flat Ribbon Cable) is the most widely used type in electronics for interconnections for power and signals from 6 to 64 pins.
- These are used to interconnect internal peripherals in computers, such as hard drives, CD drives, and floppy drives.
- They consist of highly stranded, individually-insulated conductors that are laid parallel and then fused in a flat, flexible ribbon form, hence are known as flat ribbon cables.
- To reduce the risk of reversed connections one edge of the cable is usually marked with a red stripe. By convention, the edge with the stripe is connected to pin 1 on the connector.

102. Answer: a

Explanation:

Resistance Temperature Detector (RTD).

- A Resistance Temperature Detector is an electronic device used to determine **the temperature by measuring the resistance of an electrical wire.**
- This wire is referred to as a temperature sensor.
- For the measurement of temperature with high accuracy, an RTD is used because it has good linear characteristics over a wide range of temperatures.
- Copper, Nickel, and Platinum are widely used metals for RTDs.
- RTD has a positive temperature coefficient of resistance.
- Therefore, the resistance of an RTD increases with an increase in temperature.

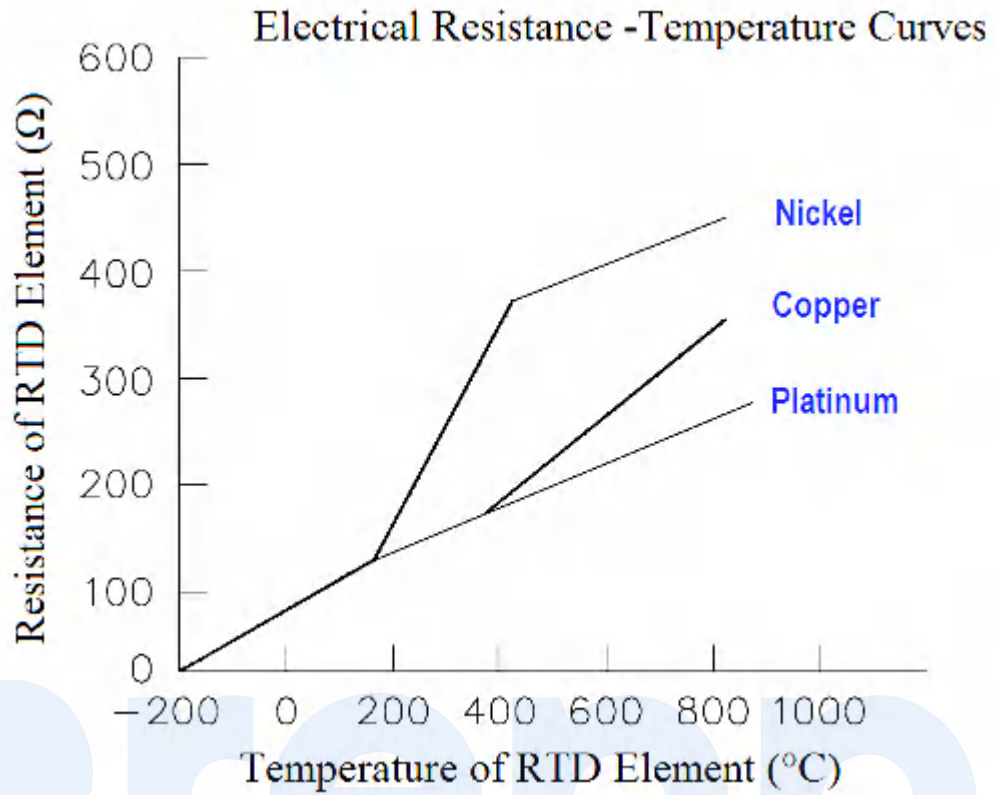

103. Answer: a

Explanation:

PNP Transistor

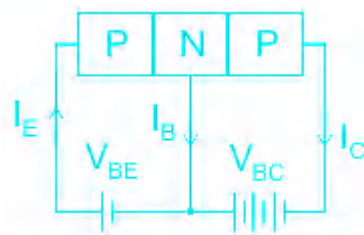

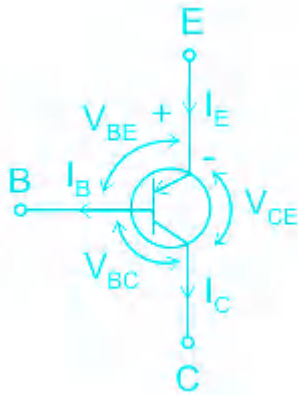

PNP transistor is a three-terminal device i.e. base, emitter, and collector.

The main function of the PNP transistor is amplification.

For amplification, the base and emitter junction must be forward bias, and the collector and emitter junction must be reverse bias.

Operating modes of transistor

<u>Operating mode</u>	<u>Base-Emitter Junction</u>	<u>Collector-Emitter Junction</u>	<u>Application</u>
Active	Forward biased	Reverse biased	Amplifier
Saturation	Forward biased	Forward biased	ON switch
Reverse active	Reverse biased	Forward biased	Attenuator
Cut-off	Reverse biased	Reverse biased	OFF switch

★ Additional Information

NPN Transistor:

- An NPN transistor is a Bipolar Junction Transistor consisting of two PN junctions in such a way that a P-type semiconductor sandwiching by two N-type Semiconductors .

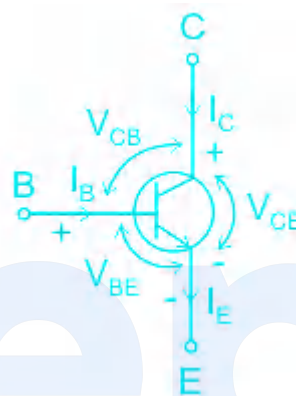
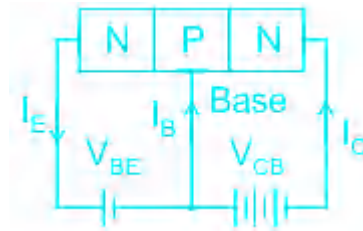

- These back to back PN junction diodes are known as the collector-base junction and base-emitter junction.
- The base-emitter junction is always connected in forward bias in Active mode therefore it has a barrier voltage (V_{BE}) of + 0.7 volts for Si and + 0.3 volts for Ge .
- The collector-base junction is always connected in reverse bias in Active mode.
- In this transistor, electrons are the majority carrier for the input current (I_E) and holes are the minority carrier.

104. Answer: d

Explanation:

Operational Amplifier (OP-AMP)

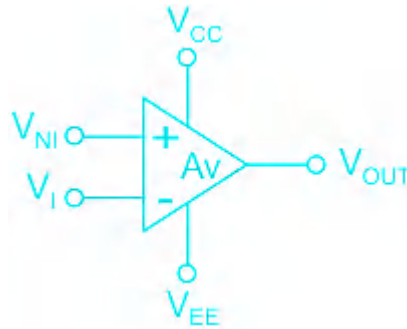

An operational amplifier (op-amp) is an integrated circuit (IC) that amplifies the difference in voltage between two inputs.

It has two terminals i.e. inverting and non-inverting terminals.

The output of the OP-AMP is:

$$V_{OUT} = A_V(V_{NI} - V_I)$$

Properties of OP-AMP

- High input impedance
- Low output impedance
- High CMRR
- High gain
- High slew rate
- Low input offset voltage
- High bandwidth

105. Answer: d

Explanation:

Uninterrupted Power Supply (UPS)

- An uninterruptible power supply or uninterruptible power source (UPS) is an electrical apparatus that provides emergency power to a load when the input power source or mains power fails.

- A UPS is typically used to protect hardware such as computers, data centers, telecommunication equipment, or other electrical equipment where an unexpected power disruption could cause injuries, fatalities, serious business disruption, or data loss.
- **The UPS always works along with a battery.**
- This battery backup provides enough time for either the connected equipment to safely shut down with the minimal risk of damage or data loss or for an alternative power source such as a backup generator to kick in and take over the powering the load.

★ Additional Information

A static transfer switch makes an online UPS different from offline UPS.

The block diagrams of both the UPS are shown in the figure.

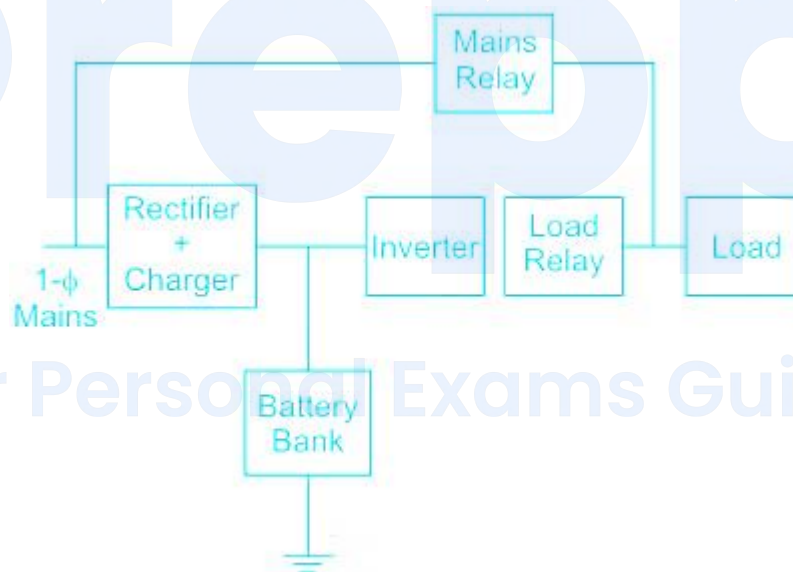

Block Diagram of ON-Line UPS

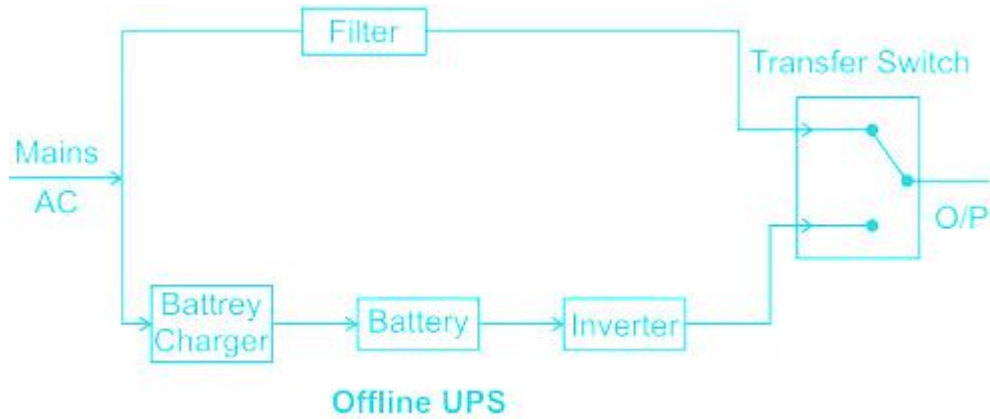

- Offline UPS requires battery
- Static transfer switches (STS) are such electrical devices which are used for very fast switching between electrical power sources.
- It is used in UPS to immediately switch main power supply, to its stored backup power.
- They perform instantaneous switching operations and thus supply immediate power to the load.

106. Answer: d

Explanation:

Connection of cells

1.) Series connection

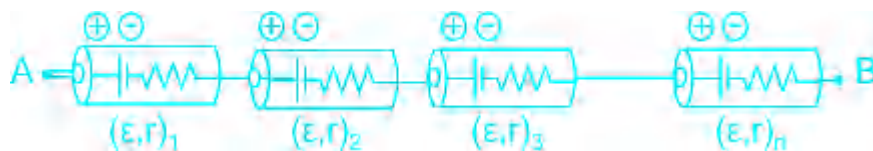

The current remains the same and the total current in the connection is equal to the current through each cell.

The total voltage across the combination is the sum of the voltage across each cell.

The total resistance across the combination is the sum of the resistance of each cell.

2.) Parallel connection

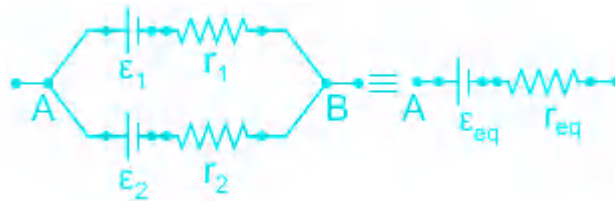

The voltage remains the same and the total voltage across the connection is equal to the voltage across each cell.

The total current across the combination is the sum of the current across each cell.

The resistance in the case of parallel connection is:

$$\frac{1}{R_{eq}} = \frac{1}{R_1} + \frac{1}{R_2} + \dots + \frac{1}{R_n}$$

Calculation

Given, $E = 1.5 \text{ V}$

$r = 0.1\Omega$

$n = 10$

$E_{eq} = 1.5 \times 10 = 15 \text{ V}$

$r_{eq} = 0.1 \times 10 = 1\Omega$

107. Answer: c

Explanation:

Effect of positive feedback on the amplifier

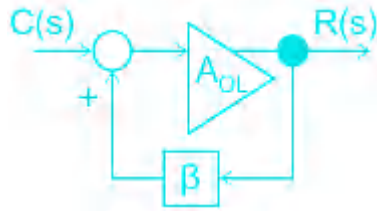

The gain of the amplifier is given by:

$$\frac{C(s)}{R(s)} = A_{CL} = \frac{A_{OL}}{1 - A_{OL}\beta}$$

Positive feedback increases the gain of the amplifier

It increases distortion in the output

It decreases the bandwidth and increases noise

108. Answer: d

Explanation:

Concept:

A bridge rectifier is of two types:

- 1) Bridge Type Full Wave Rectifier
- 2) Center-Tap Full Wave Rectifier

A Bridge type full wave rectifier contains 4 diodes as shown:

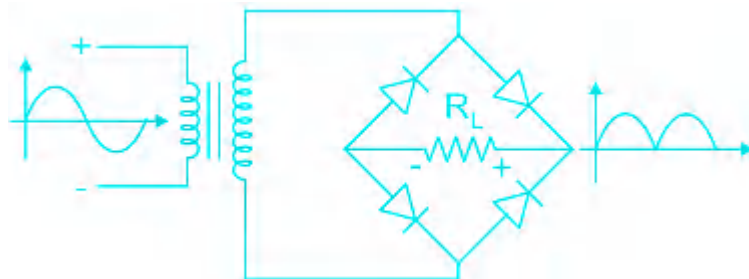

Working:

For a positive half cycle, two diodes will act as short-circuit as shown

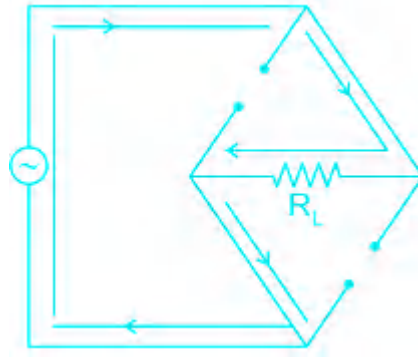

Similarly, for a negative half cycle, the other two diodes will be short-circuited resulting in a full-wave rectified output.

Center-Tap Full Wave Rectifier :

It consists of two diodes as shown:

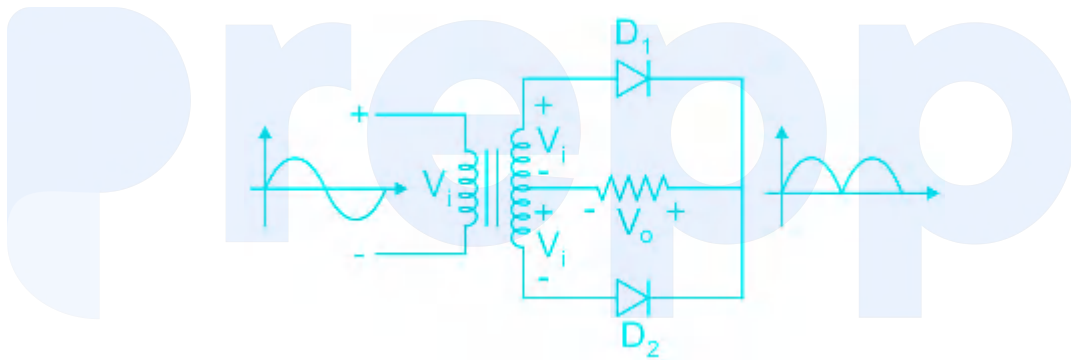

1φ full wave rectifier

The average output voltage is:

$$V_{o(avg)} = \frac{2V_m}{\pi}$$

The RMS output voltage is:

$$V_{o(RMS)} = \frac{V_m}{\sqrt{2}}$$

109. Answer: c

Explanation:

Types of Digital circuits

1.) Decoder

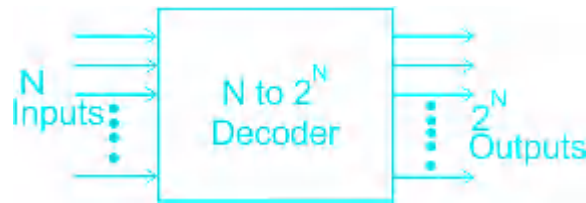

- A decoder is a circuit that changes a binary code into a particular set of signals.
- The set of signals can be decimal, octal, or hexadecimal.
- It converts N inputs into 2^N outputs.

2.) Encoder

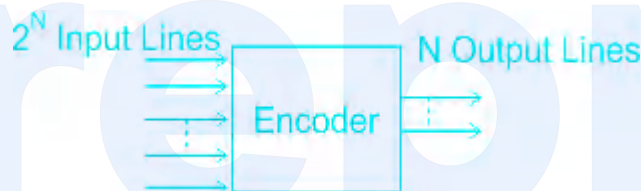

- An encoder is a circuit that changes a particular set of signals into binary code.
- It converts 2^N inputs to N outputs.

3.) Multiplexer

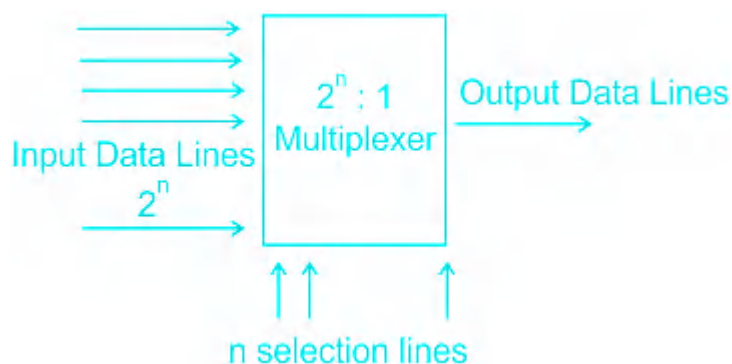

- A multiplexer is a circuit that has 2^n input lines and a single output line.
- It converts multiple inputs into a single output.
- The output is produced as per the status of the selection line.

4.) Demultiplexer

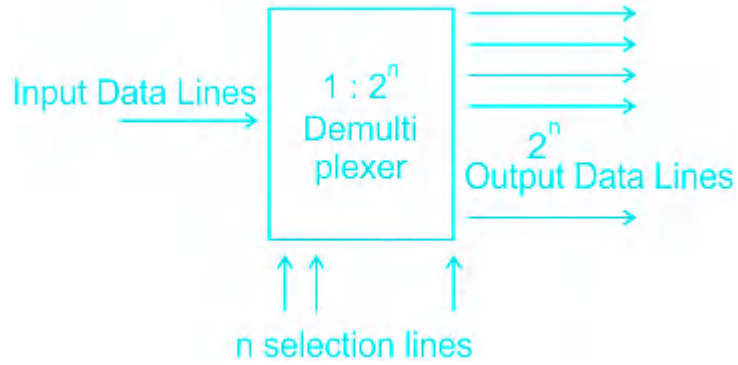

- A demultiplexer is a circuit that has n input lines and a 2^n output line.
- It converts single input into multiple outputs.

110. Answer: d

Explanation:

Types of logic gates

1.) AND Gate



A	B	Y = AB
0	0	0
1	0	0
0	1	0
1	1	1

When any of the inputs is low, the output is always low.

When all the inputs are high, then only the output is high.

2.) OR gate



A	B	Y = A+B
0	0	0
1	0	1
0	1	1
1	1	1

When any of the inputs is high, the output is always high.

When all the inputs are low, then only the output is low.

3.) NOR Gate



A	B	Y = $\overline{A+B}$
0	0	1
1	0	0
0	1	0
1	1	0

When any of the inputs is high, the output is always low.

When all the inputs are low, then only the output is high.

4.) NAND Gate

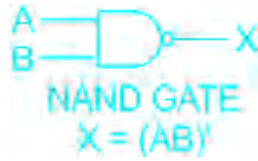

A	B	$Y = \overline{AB}$
0	0	1
1	0	1
0	1	1
1	1	0

When any of the inputs is low, the output is always high.

When all the inputs are high, then only the output is low.

111. Answer: d

Explanation:

Single mode fiber cables are used in home installations.

Types of Fiber cables

1.) Single mode fiber

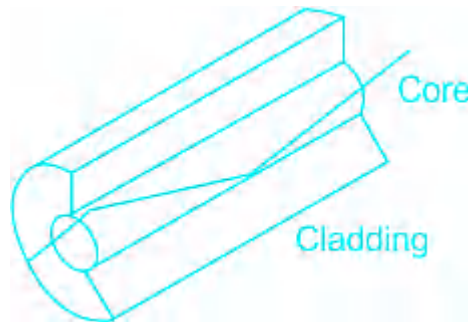

- It has a much smaller core size of 9 microns and has a single light path and can travel much longer distances of up to 100km.
- Single-mode fiber features only one transmission mode.

- Compared with multi-mode fiber, it can carry higher bandwidths; however, it needs to have a light source having a narrow spectral width.
- These require more expensive electronics which operate in the 1310 and 1550nm windows and **are typically used in longer distance LAN's, Cable TV and telephony applications.**

2.) Multimode fiber

- It can carry multiple light rays (modes) at the same time by having varying optical properties at the core; essentially light travelling the shortest path (down the middle) travels the slowest.
- The larger core simplifies connections and takes advantage of the lower cost LED & VCSEL technologies which operate in the 850nm window.
- Due to dispersion the range is limited so it tends to be used as premises cabling when less than a kilometer..
- It comes in two core sizes, 62.5 and 50 microns.

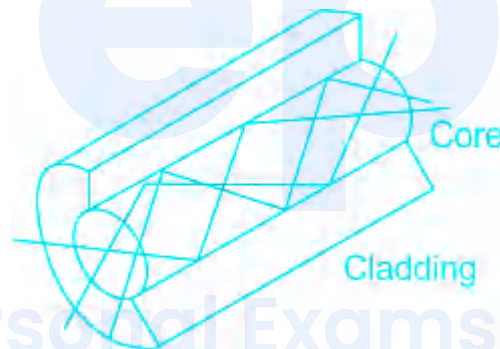

112. Answer: c

Explanation:

In combinational circuits, the output is dependent only upon the present input.

<u>Combinational Circuits</u>	<u>Sequential Circuits</u>
The output depends entirely on the present input	The output depends on the present as well past input
No feedback is present between the input and output	A feedback path exists between the input and output
It exhibits a faster speed	It exhibits slower speed
These circuits do not have a clock, thus they don't require triggering	Because a sequential circuit depends on a clock, it usually requires triggering
They do not possess any memory element	They always possess a memory element
Example- De-multiplexer, Multiplexer, Encoder etc.	Example- Counters, Flip-flops etc.

113. Answer: c

Explanation:

Metal Oxide Silicon Field Effect Transistors (MOSFET)

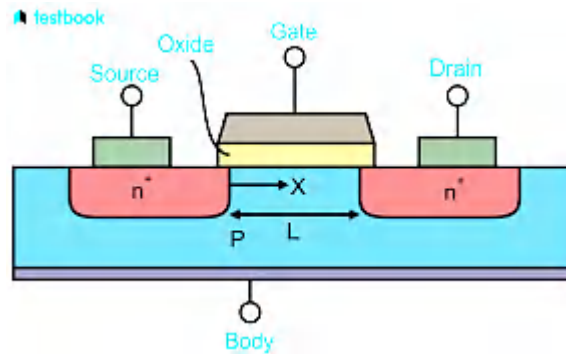

- It is a voltage-controlled three-terminal device that is used for switching and amplification purposes.
- The terminals are the drain, gate, and source.
- MOSFETs are of two classes: Enhancement mode and depletion mode. Each class is available as an n-channel or p-channel.
- The voltage at the gate controls the operation of the MOSFET. In this case, both positive and negative voltages can be applied to the gate as it is insulated from the channel.
- With a negative gate bias voltage, it acts as a depletion MOSFET while with a positive gate bias voltage, it acts as an Enhancement MOSFET.
- **The output impedance of the MOSFET is very high ideally infinite for a common source and common gate configuration.**
- The output impedance of the MOSFET is a low value for common drain configuration.

Your Personal Exams Guide

114. Answer: a

Explanation:

Digital storage oscilloscope (DSO)

- A digital storage oscilloscope (DSO) is an electronic instrument that measures and records electrical signals.
- **It converts the analog signal into a digital format and stores it in its digital memory.**
- The input analog signal is sampled and then converted into a digital signal at each sample time.

- The sampling frequency should be not less than the Nyquist rate to avoid aliasing.
- These digital values are then turned back into an analog signal for display on a cathode ray tube (CRT).
- Digital storage oscilloscopes have two operating modes: single-shot and repetitive.
- In single-shot mode, the oscilloscope acquires and stores one signal.
- In repetitive mode, the oscilloscope continuously acquires and stores signals.

115. Answer: a

Explanation:

Inductor

An inductor is an electrical element that stores energy in form of a magnetic field.

The inductor does not allow AC to flow through it but does allow DC to flow through it.

The total flux linkage is proportional to the current flowing through the inductor.

$$\psi \propto I$$

$$\psi = L \times I$$

$$L = \frac{\psi}{I}$$

where, L = Inductance

ψ = Flux linkage

I = Current

116. Answer: b

Explanation:

Integrated circuit 78xx

- 78xx is a family of self-contained fixed linear series voltage regulator integrated circuits.
 - The 78xx family is commonly used in electronic circuits requiring a regulated power supply due to their ease of use and low cost.
 - They provide a stable output voltage from a slightly higher input voltage.
 - These ICs have built-in protection against a circuit drawing too much power.
 - They have protection against overheating and short-circuits, making them quite robust in most applications.
-

117. Answer: b

Explanation:

MS Excel

- Microsoft Excel is a spreadsheet that is used for calculation or computation capabilities, graphing tools, pivot tables, and a macro programming language.
 - Excel forms part of the Microsoft Office suite of software.
 - With the help of MS Excel arithmetic calculations such as addition, subtraction, multiplication, division, percentage, etc. can be performed.
 - **The solution of higher complex calculations such as differentiation, integration or partial fraction, etc. is not possible in MS Excel.**
-

118. Answer: b

Explanation:

Eddy current proximity sensors

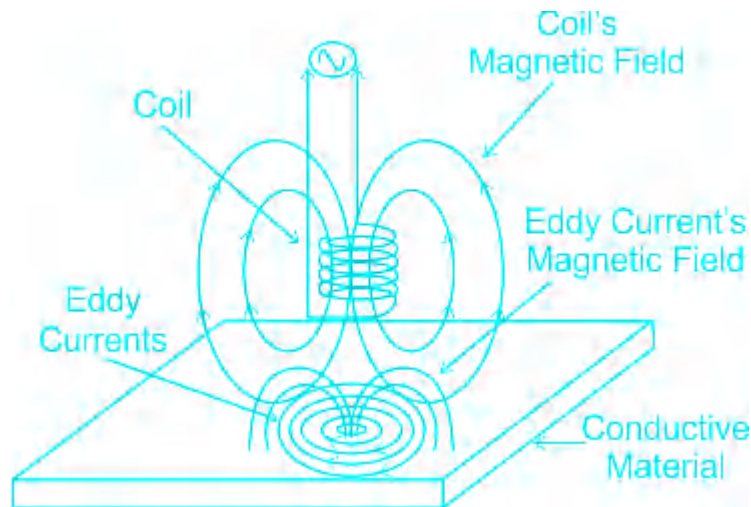

- Eddy current is a circular current that is induced by a conductor when it is kept in a changing magnetic field.
- **Eddy current sensors are used to detect the presence of non-magnetic conductive material such as metal.**
- Eddy current sensor operates based on the inductive eddy-current principle.
- When the sensing coil is supplied with an alternating current, it causes a magnetic field to form around the coil.
- If an electrically conducting material is placed in this field, an eddy current field is induced according to Faraday's induction law.
- When the object moves, it causes a change in the impedance of the coil, which is proportional to the change in the distance between the sensor and the target.

119. **Answer: b**

Explanation:

Cathode Ray Oscilloscope (CRO).

CRO is a device that is used for the measurement of parameters of electrical quantities like frequency, amplitude, time period, and phase difference.

Components of CRO:

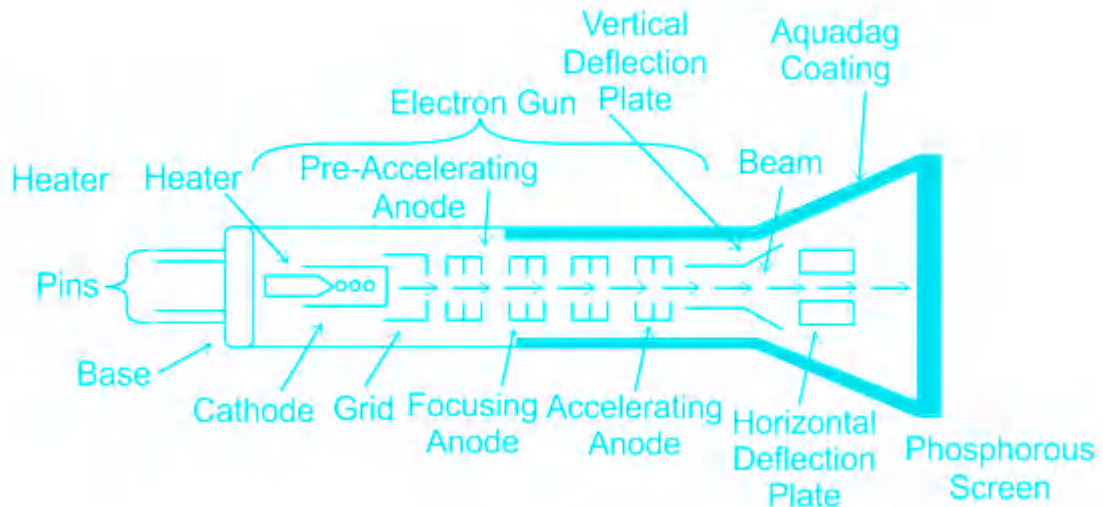

1.) Electron Gun

- The electron gun is used to produce a narrow beam of electrons. It consists of a filament enclosed in a cylindrical cathode, a ring-shaped electrode called the control grid, and Two cylindrical anode electrodes known as the focusing anode and accelerating anode.
- The filament is heated when current flows through it. It is used to heat up the cathode.

2.) Deflection System

- The deflection system allows the electron beam to be deflected from its straight-line path when it leaves the electron gun.
- The deflection system consists of two sets of parallel plates. One set which is arranged vertically is known as X-plates and the other set which is arranged horizontally is known as Y-plates.

3.) Fluorescent Screen

- The fluorescent screen is coated on the inside surface with some fluorescent material such as phosphor or zinc sulfide.
- When electrons in the beam strike the screen, the material fluoresces and becomes luminous or glows. This enables a bright spot to appear wherever an electron beam strikes the screen.
- When these high-energy electrons strike the screen, the fluorescent coating on the screen converts the kinetic energy of the electrons into light energy.

120. Answer: d

Explanation:

IC 7402

7402 IC is a device containing four independent gates each of which performs the logic NOR function.

According to logic NOR, if any of the input is high the output is always low.

The truth table of NOR Gate is given below:



A	B	$Y = \overline{A + B}$
0	0	1
1	0	0
0	1	0
1	1	0

121. Answer: c

Explanation:

Operating system

An Operating System (OS) is software that acts as an interface between computer hardware components and the user.

The purpose of an operating system is to provide an environment in which a user can execute programs conveniently and efficiently.

Some examples of operating systems include Apple macOS, Microsoft Windows, Google's Android OS, Linux Operating System, and Apple iOS.

Features of the Operating system

1. **Convenience:** It makes computers more convenient and easy to use.
2. **Efficiency:** It allows the computer system resources to be used efficiently.
3. **Ability to Evolve:** It should be constructed in such a way as to permit the effective development, testing, and introduction of new system functions at the same time without interfering with service.
4. **Throughput:** It should be constructed so that It can give maximum throughput(Number of tasks per unit time).

122. Answer: b

Explanation:

LCR meter

- An LCR meter is a type of electronic test equipment used to measure the inductance (L), capacitance (C), and resistance (R) of an electronic component.
- **The series combination of L, C, and R is known as the impedance.**
- It is used in radio and communication engineering and it can also be used to select a certain narrow range of frequencies from the total spectrum of ambient radio waves.
- The LCR meter measures current, voltage, and phase angle and calculates the corresponding LCR values which can be represented in a number of forms.

★ Additional Information

Cathode Ray Oscilloscope (CRO)

- CRO is a device that is used for the measurement of parameters of electrical quantities like frequency, amplitude, time period, and phase difference.

Digital storage oscilloscope (DSO)

- A digital storage oscilloscope (DSO) is an electronic instrument that measures and records electrical signals.
- It converts the analog signal into a digital format and stores it in its digital memory.

Function generator

- A function generator is a specific form of signal generator that is able to generate waveforms typically sine and square waves.

123. Answer: a

Explanation:

Bipolar Junction Transistor (BJT)



BJT is a current-controlled device.

BJT is a three-terminal device i.e. base, collector, and emitter.

The conduction in BJT is due to the minority as well as the majority charge carrier.

Current ratios in BJT

1.) Common base current gain

It is the ratio of collector current to emitter current.

It is denoted by α

$$\alpha = \frac{I_C}{I_E}$$

2.) Common emitter current gain

It is the ratio of collector current to base current.

It is denoted by β

$$\beta = \frac{I_C}{I_B}$$

3.) Common collector current gain

It is the ratio of emitter current to base current.

It is denoted by γ

$$\gamma = \frac{I_E}{I_B}$$

Also, $\gamma = \alpha + \beta$

124. Answer: b

Explanation:

Race around condition in JK flip flop

In JK Flip-flop, if $J=K=1$, and if $clk=1$ for a long period of time, then Q output will toggle as long as CLK is high, which makes the output of the flip-flop unstable or uncertain.

This problem is called race around condition in J-K flip-flop.

The truth table of the JK flip-flop is given below:

J	K	Q_{n+1}
0	0	Q_n
0	1	0
1	0	1
1	1	Invalid

The invalid at $J=1$ and $K=1$ is known as the race-around condition.

To overcome this condition, a Master-slave JK flip flop is used.

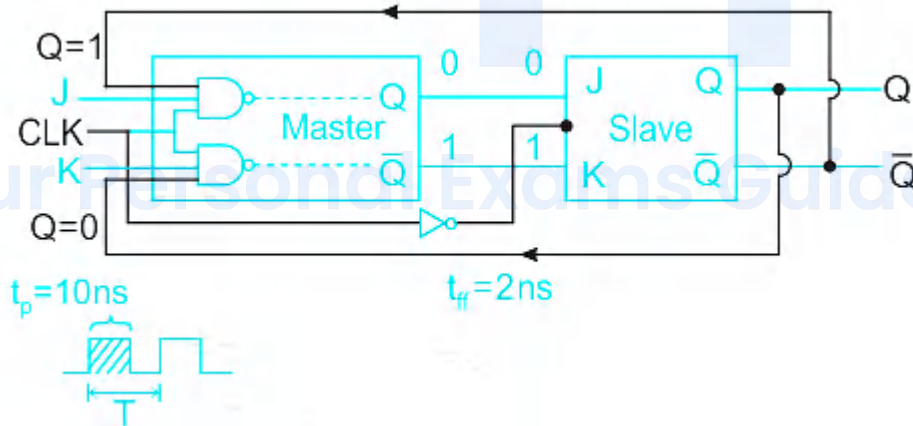

- The master-slave flip flop is constructed by combining two JK flip flops.
- These flip-flops are connected in a series configuration. In these two flip flops, the 1st flip flop work as a "master", called the master flip flop, and the 2nd work as a "slave", called the slave flip flop.
- When the clock pulse is true, the slave flip flop will be in the isolated state, and the system's state may be affected by the J and K inputs.
- The "slave" remains isolated until the CP is 1.

- When the CP is set to 0, the master flip-flop passes the information to the slave flip-flop to obtain the output.

125. Answer: c

Explanation:

Two-stage RC coupled amplifier

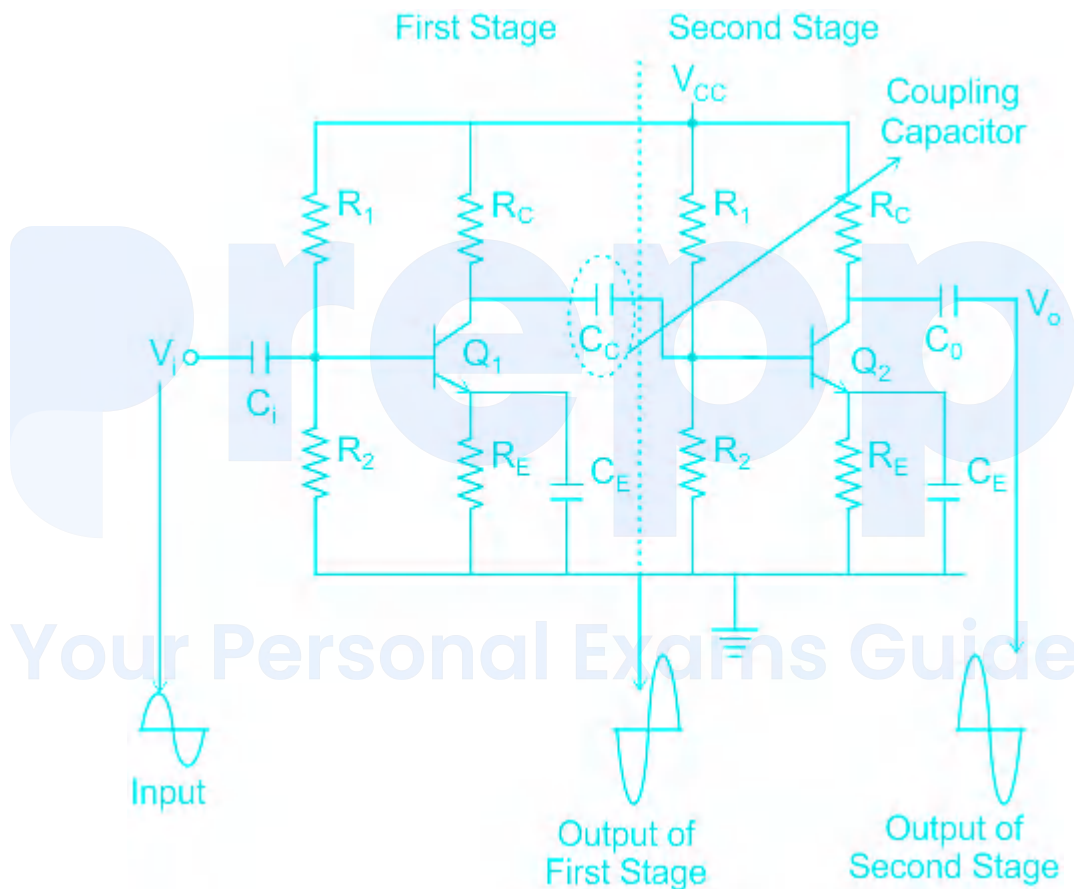

- A Resistance Capacitance (RC) Coupled Amplifier is basically a multi-stage amplifier circuit extensively used in electronic circuits.
- In this amplifier, two common emitter amplifiers are connected through a coupling capacitor (C_c).
- The output from the emitter of the first amplifier is the input to the base of the second amplifier.

- The purpose of the coupling capacitor is to block DC voltage and pass AC voltage.
- As a result of this, there is no DC interaction between stages i.e. the DC voltage of the first stage does not disturb the operating point of the second stage.
- Polyester film capacitors is commonly used for coupling between two circuits.

126. Answer: d

Explanation:

Modeling of BJT amplifier

An amplifier can be represented by a hybrid parameter or an h parameter.

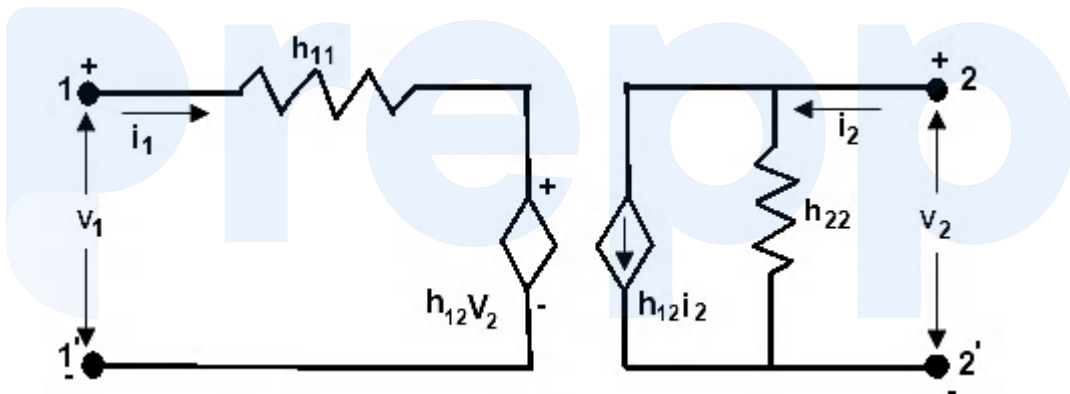

Here, $V_1, I_2 = f(I_1, V_2)$

The h parameter equations are:

$$V_1 = h_{11}I_1 + h_{12}V_2$$

$$I_2 = h_{21}I_1 + h_{22}V_2$$

where V_1 and V_2 are the input and output voltage

I_1 and I_2 are the input and output current

Parameter	Meaning	Condition
h_{11}	Input resistance	Output shorted
h_{12}	Reverse voltage gain	Input open
h_{21}	Forward current gain	Output shorted
h_{22}	Output conductance	Input open

127. Answer: b

Explanation:

Capacitor

Your Personal Exams Guide

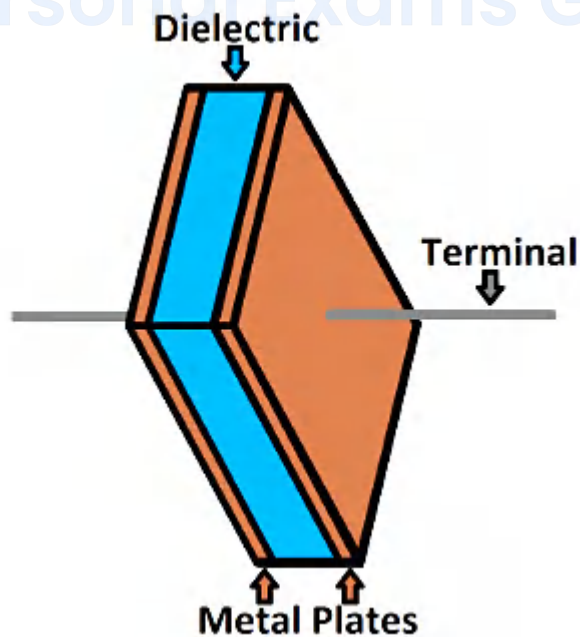

A capacitor is created out of two metal plates and an insulating material called a dielectric.

The dielectric is made of insulating materials such as paper, glass, rubber, ceramic, plastic, etc.

The capacitance of a capacitor is given by:

$$C = \frac{\epsilon_0 \epsilon_r A}{d}$$

where, C = Capacitance

ϵ_0 = Permittivity of free space

ϵ_r = Relative permittivity

A = Area of the plates of the capacitor

d = Distance between the plates of the capacitor

128. Answer: b

Explanation:

- Shortwave radio refers to radio broadcasts on a portion of the radio spectrum in the frequency range of 1700 – 30000 kHz (1.7 to 30 MHz).
- Because smaller wavelengths correspond to higher frequencies, shortwave radio received its name because its wavelengths are shorter than the longer wavelengths used in early radio communications.
- Since the length of the antenna is directly proportional to the wavelength, hence short wavelength means the length of the antenna is also short.
- For the short wavelength, high range of frequency is required generally in the range of MHz.

129. Answer: c

Explanation:

Concept

The power of the bulb is given by:

$$P = \frac{V^2}{R}$$

where, P = Power

V = Voltage

R = Resistance

Calculation

Given, V = 200 volts

R = 50 Ω

$$P = \frac{(220)^2}{50}$$

P = 968 W

130. Answer: a Your Personal Exams Guide

Explanation:

Transformer

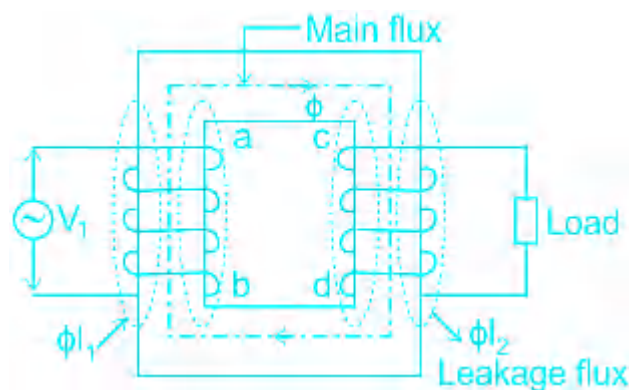

- A transformer is a static device that operates on AC voltage.
 - It consists of primary and secondary winding that are electrically isolated from each other.
 - **It is used to step up or step down the AC voltage, hence it performs AC-to-AC conversion.**
 - It is used to transfer power from one circuit to another without a change in frequency.
 - The transformer works on the principle of Faraday's law of electromagnetic induction and mutual induction.
-

131. Answer: b

Explanation:

Concept

The power across a resistance is:

$$P = I^2 R$$

where, P = Power

I = Current

R = Resistance

Calculation

Given, I = 1.414 A

R = 50 Ω

$$P = (1.414)^2 \times 50$$

P = 100 watt

132. Answer: c

Explanation:

Frequency

It is defined as the number of cycles completed in 1 second.

50 Hz means 50 cycle is completed in 1 second.

For 10 seconds, the number of cycles completed is given by:

$$f = 50 \times 10$$

$$f = 500$$

The number of cycles completed in 10 seconds is 500.

133. Answer: a

Explanation:

Ripple in Switched Mode Power Supply (SMPS)

Ripple is the small unwanted residual periodic variation of the direct current (dc) output of a power supply that has been derived from an alternating current (ac) source.

The % ripple is given by:

$$\% \text{ ripple} = \frac{\text{Output AC component}}{\text{Output DC component}} \times 100$$

The input ripple of SMPS is high.

This ripple is due to incomplete suppression of the alternating waveform within the power supply.

The ripple can be reduced by smoothing capacitors which converts the ripple voltage into a smoother dc voltage.

Aluminum electrolytic capacitors are widely used for this and have capacitances of 100uF or more.

134. Answer: d

Explanation:

The correct answer is option 4.

Unijunction Transistor (UJT)

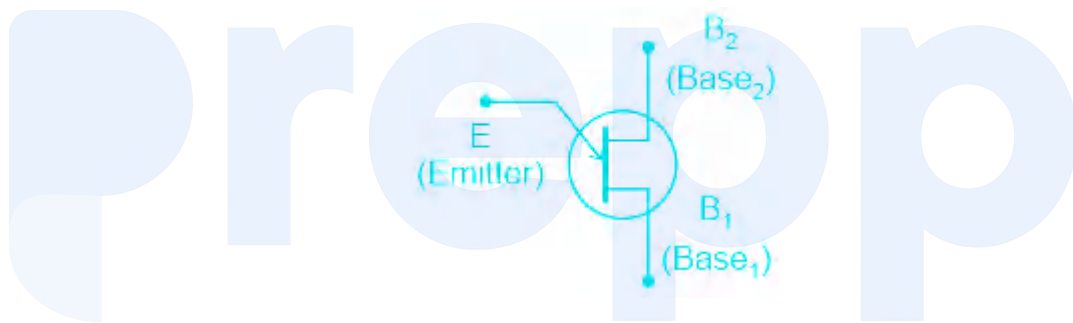

UJT is a two-layered, three-terminal, solid-state switching device. Unlike a BJT, it has only one junction that's why it is called Unijunction Transistor.

UJT can act as an electrically operated solid-state switch.

UJT is also known as a double base diode because like a diode it also has two-layer and one junction. Just difference is diode has two terminals whereas UJT has three terminals.

Application and Uses of UJT

1. The main application of UJT is, it is used for triggering SCR and TRIAC.
2. These are used in synchronized oscillators, and pulse generator circuits that work at low to moderate frequencies.
3. It is used in digital voltage and frequency measurement circuits.
4. These are used to make relaxation oscillator circuits.

5. These are used in phase control and timing circuits.

6. These are used for different types of waveform generation such as Sawtooth Wave generation.

135. Answer: b

Explanation:

Schmitt trigger

Schmitt Trigger is a Bi-stable Multivibrator and its output remains in either of the two stable states i.e. $+V_{sat}$ or $-V_{sat}$

The circuit gives $+V_{sat}$ when the non-inverting input is greater than the inverting input.

The circuit gives $-V_{sat}$ when the inverting input is greater than the non-inverting input.

As the output oscillates between the two states, the Schmitt trigger always generates a square wave.

Working of Schmitt trigger

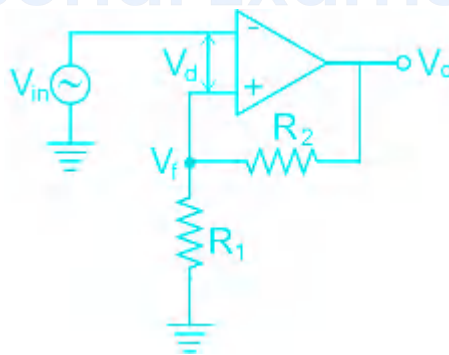

When $V_{ref} > V_{in}$, the output is $+V_{CC}$

When $V_{ref} < V_{in}$, the output is $-V_{EE}$

The reference voltage is either V_{UT} or V_{LT} .

Upper threshold voltage $(V_{UT}) = +V_{CC}(\frac{R_2}{R_1+R_2})$

Lower threshold voltage $(V_{LT}) = -V_{EE}(\frac{R_2}{R_1+R_2})$

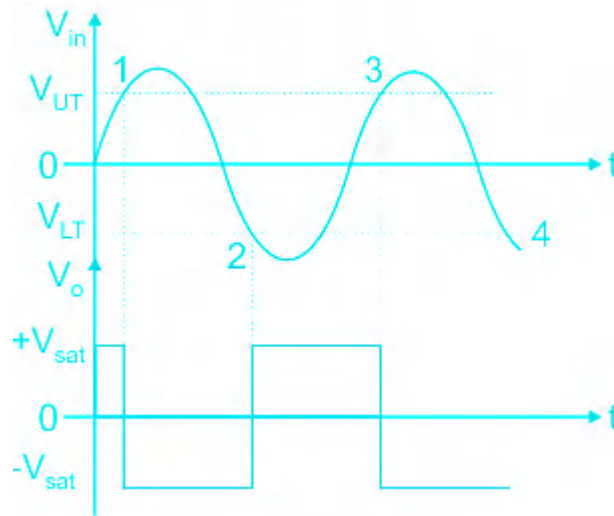

136. Answer: a

Explanation:

1.) Analog to digital converter

- An analog-to-digital converter (also known as an ADC or an A/D converter) is an electronic circuit that measures a real-world signal (such as temperature, pressure, acceleration, and speed) and converts it to a digital representation of the signal.
- They first sample the signal, then quantify it to determine the resolution of the signal, and finally set binary values and send it to the system to read the digital signal.
- Successive Approximation, Dual slope, and Counter type are a few methods used for analog-to-digital conversion.

2.) Comparator

- A comparator circuit compares the input given at its input terminal and produces output according to the highest input.

- An OP-AMP working as a comparator produces $+V_{sat}$ when input at the non-inverting terminal is greater than the inverting terminal.
- An OP-AMP produces $-V_{sat}$ when input at the inverting terminal is greater than the non-inverting terminal.

3.) Magnetic field sensor

- Magnetic field sensors are devices that detect and measure magnetic fields around permanent magnets, current conductors, and electrical devices.
- The working principle is based on the measurement of changes in the magnetic moment of magnetic material when exposed to magnetic fields.

4.) Hall sensor

- The hall effect sensor is a type of magnetic sensor which can be used for detecting the strength and direction of a magnetic field produced from a permanent magnet or an electromagnet with its output varying in proportion to the strength of the magnetic field being detected.

137. Answer: b

Explanation:

Types of the electrical element

1.) Resistor

- The resistor is an electrical element that opposes the flow of electric current through it.
- This property is known as resistance.
- The resistor does not store energy rather it dissipates energy.
- The SI of resistance is ohm and is denoted as Ω .

2.) Inductor

- The inductor is an electrical element that opposes the sudden change in current.

- The inductor stores energy in form of a magnetic field.
- This property is known as inductance.
- The SI of inductance is Henry and is denoted as H.

3.) Capacitor

- The capacitor is an electrical element that opposes the sudden change in voltage.
 - The capacitor stores energy in form of an electric field.
 - This property is known as capacitance.
 - The SI of capacitance is Farad and is denoted as F.
-

138. Answer: b

Explanation:

Heat Sink

- **A heat sink is a mechanical device. It is connected to power transistor in order to dissipate heat generated.**
 - The heat flows through the heat sink and is radiated to surrounding air. If a heat sink is not used then all the heat has to be transferred from a transistor case to surrounding air causing case temperature to increase.
 - In a transistor, the collector to base junction temperature rises because of self-heating. The self-heating is due to the power dissipated at collector junction.
 - This power dissipation at junction causes the junction temperature to rise, and this in turn increases the collector current which causes further increase in power dissipation.
 - If the phenomenon continues then it may result in permanent damage of the transistor. This is known as thermal runaway.
-

139. Answer: a

Explanation:

Losses in Transformer

There are two types of losses present in the transformer i.e. core loss and copper loss.

1.) Core loss or iron loss

These losses occur in the core of the transformer. These are of two types i.e. eddy current loss and hysteresis loss.

Eddy current loss and hysteresis loss depend upon the magnetic properties of the material used to construct the core.

a.) Eddy's current loss

- In the transformer, AC current is supplied to the primary winding which sets up alternating magnetizing flux.
- When this flux links with a secondary winding, it produces induced emf. But some part of this flux also gets merged with other conducting parts like steel core or iron body or the transformer, which will result in induced emf in those parts, causing small circulating current in them.
- This current is called an eddy current. Due to these eddy currents, some energy will be dissipated in the form of heat.

b.) Hysteresis loss

- Hysteresis loss is due to the reversal of magnetization in the transformer core.
- This loss depends upon the volume and grade of the iron, frequency of magnetic reversals, and value of flux density.

2.) Copper loss

- These losses occur due to the ohmic resistance of the transformer windings.
- Copper loss is proportional to the square of the current, and the current depends on the load. Hence copper loss in the transformer varies with the load.

140. Answer: c

Explanation:

The correct answer is option 3.

Fiber Optic Receivers

- Fiber optic receivers convert light signals into electrical signals for use by equipment such as computer networks.
- These electro-optical devices consist of an optical detector, a low-noise amplifier, and signal conditioning circuitry.
- After the optical detector converts the incoming optical signal into an electrical signal, the amplifier increases it to a level suitable for additional signal processing.
- **Two types of semiconductors are used in fiber optic receivers i.e. silicon semiconductor such as photo diode and indium gallium arsenide semiconductors.**
- Silicon semiconductors are used in short-wavelength receivers with a range of 400 nm to 1100 nm.
- Indium gallium arsenide semiconductors are used in long-wavelength receivers with a range of 900 nm to 1700 nm.

141. Answer: c

Explanation:

Accumulator in 8051 microcontroller

- The Accumulator is a general-purpose register that is used to store the results of a large number of instructions.
- It can hold an 8-bit (1-byte) value and is the most versatile register the 8051 has due to the many numbers of instructions that make use of the accumulator.

- The accumulator is also identified as register A.
- Whenever any arithmetic operation is performed between two numbers, the resultant of that operation is stored in the accumulator.

142. Answer: a

Explanation:

The correct answer is option 1.

Abbreviations of power electronic devices

<u>Abbreviations</u>	<u>Full Form</u>
DIAC	Diode for alternating current
TRIAC	Triode for alternating current
SCR	Silicon controlled rectifier
FET	Field effect transistor
MOSFET	Metal Oxide Semiconductor Field Effect Transistor
BJT	Bipolar Junction Transistor
IGBT	Insulated bipolar junction transistor

143. Answer: d

Explanation:

Hexadecimal representation system

prepp

Your Personal Exams Guide

Hexadecimal	Binary code
0	0000
1	0001
2	0010
3	0011
4	0100
5	0101
6	0110
7	0111
8	1000
9	1001
A	1010

prepp
Your Personal Exams Guide

B	1011
C	1100
D	1101
E	1110
F	1111

A is represented by 1010 and 4 is represented by 0100.

$$4A = 01001010$$

The rightmost number is 0, so 4A can be represented as 1001010

144. Answer: a

Explanation:

Single phase induction motor is used in household refrigerators.

Applications of different 1 ϕ induction motor

<u>Single phase motor</u>	<u>Application</u>
Split phase motor	Shop grinders, Washing machine, Belt driven conveyors
Capacitor run motor	Compressors, Conveyors, Refrigerators, Air Conditioners, Ceiling fans
Shaded pole motor	Hair dryers, Toys, Record players, Small fans, Electric clocks
AC series motor	Sewing machine, Table fans, Food mixer

★ Additional Information

<u>Motor</u>	<u>Application</u>
DC series motor	Traction system, Cranes, Air compressor
DC shunt motor	Lathe machines, Pumps, Blowers, Conveyors belts
DC compound motor	Presses, Shears, Elevators, Rolling mills
Stepper motor	3D printing equipment, CNC milling machines

145. Answer: d

Explanation:

Push-Pull Amplifier

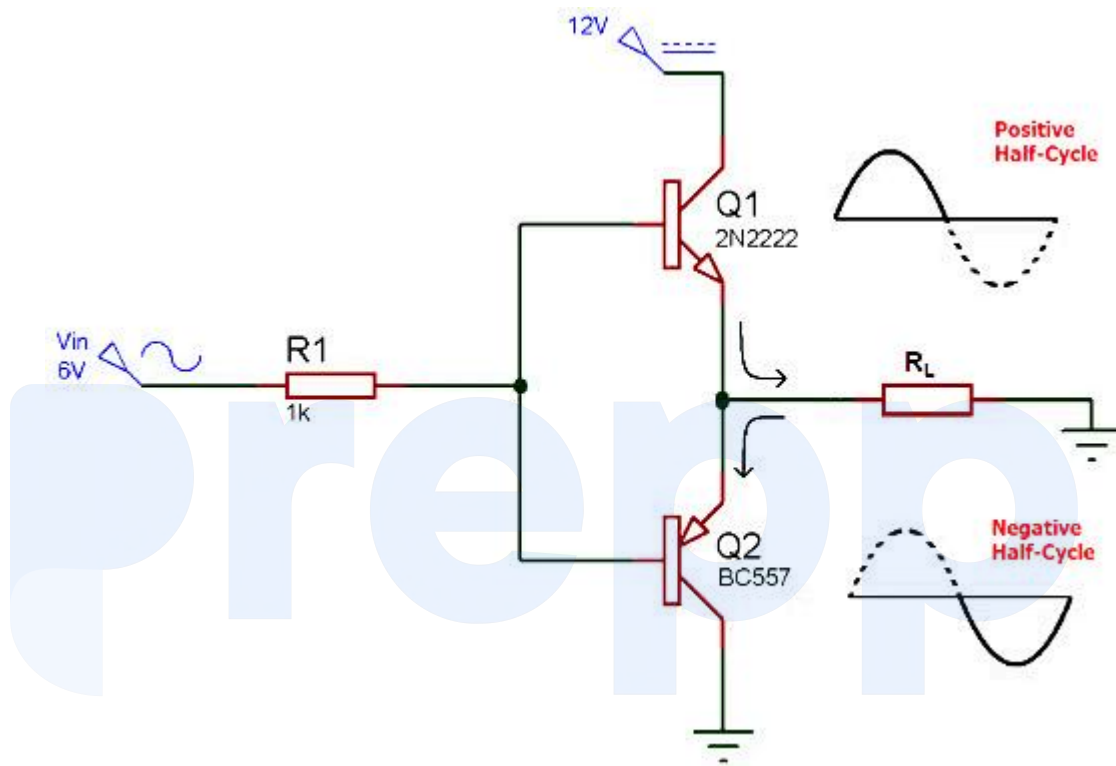

Push-Pull Amplifier is a power amplifier which is used to supply high power to the load.

It consists of two transistors in which one is NPN and another is PNP. One transistor pushes the output on positive half cycle and other pulls on negative half cycle, this is why it is known as Push-Pull Amplifier.

The advantage of Push-Pull amplifier is that there is no power dissipated in output transistor when signal is not present.

There are three classification of Push-Pull Amplifier but generally Class B Amplifier is considered as Push Pull Amplifier.

1.) Class A amplifier

- Class A configuration is the most common power amplifier configuration.
- It consists of only one switching transistor which is set to remain ON always.
- It produces minimum distortion and maximum amplitude of output signal.
- The efficiency of Class A amplifier is very low near to 30%.
- The stages of the Class A amplifier allows same amount of load current to flow through it even when there is not input signal connected, therefore large heat sinks are needed for the output transistors.

2.) Class B amplifier

- Class B amplifier is the actual Push-Pull Amplifier.
- The efficiency of Class B amplifier is higher than Class A amplifier, as it consists of two transistors NPN and PNP.
- The Class B amplifier circuit is biased in such a way that each transistor will work on one half cycle of the input waveform. Therefore, the conduction angle of this type of amplifier circuit is 180° .

3.) Class AB amplifier

- The Class AB amplifier circuit is the combination of both Class A and Class B amplifier.
- A common method to remove that crossover distortion in Class B amplifier is to bias both the transistor at a point slightly above then the cut-off point of transistor. Then this circuit is known as Class AB amplifier circuit.

146. Answer: a

Explanation:

Cell

A cell is a single unit of device that converts chemical energy into electrical energy.

It is of two types:

1.) Primary Cell

- Primary cells are the ones which cannot be recharged neither reused after the expiration of the lifetime.
- Primary cells have high density and get discharged slowly.
- Since there is no fluid inside these cells they are also known as dry cells.
- The internal resistance is high and the chemical reaction is irreversible. Its initial cost is cheap and also primary cells are easy to use.

2.) Secondary Cell

- Secondary cells need to be recharged when the charge gets over.
- Secondary cells have low energy density and are made of molten salts and wet cells.
- The internal resistance is low and the chemical reaction is reversible.
- Its initial cost is high and is a little complicated to use when compared to the primary cell.

147. Answer: b

Explanation:

Solar cell

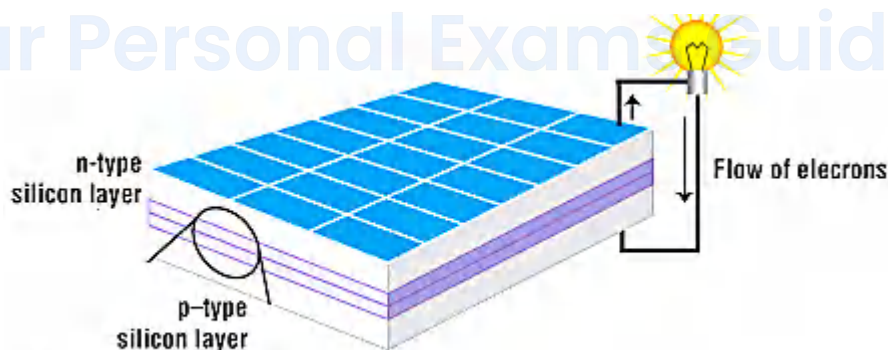

- A solar cell is an electronic device that converts the energy of light directly into electricity by the photovoltaic effect.
- The photoelectric effect is the emission of electrons when electromagnetic radiation, such as light, hits a material. Electrons emitted in this manner are called photoelectrons.

- **The solar cell is made up of silicon.**
 - A solar cell consists of a layer of p-type silicon placed next to a layer of n-type silicon.
 - When we connect the n-type and p-type layers with a metallic wire, the electrons will travel from the n-type layer to the p-type layer by crossing the depletion zone and then go through the external wire back of the n-type layer, creating a flow of electricity.
-

148. **Answer: d**

Explanation:

Burglar Alarm

- A burglar alarm is a security device that makes an alarming sound in case a person tries to gain forced or unauthorized entrance into a building.
- **It consists of infrared LED's.**
- A burglar alarm basically works on the principle of automatic conversion of energy from one form to the other due to variation in parameters such as motion.
- The burglar alarm circuit typically converts electrical energy into sound energy upon sensing movement.
- It detects the human body movement, whenever there is any body movement, the voltage at output pin changes.
- It detects the change in heat, and produce output whenever such detection occurs.

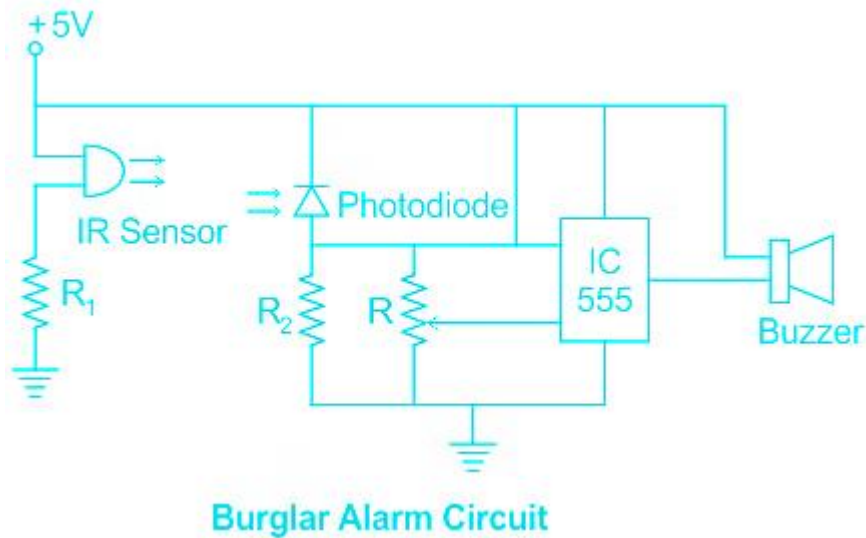

149. Answer: b

Explanation:

Capacitor

The reactance of a capacitor is given by:

$$X_c = \frac{1}{2\pi fC}$$

For the DC source, $f = 0$

$$X_c = \frac{1}{0}$$

$$X_c = \infty$$

Since the reactance offered by the capacitor is ∞ , hence the circuit acts as an open circuit.

Inductor

The reactance of an inductor is given by:

$$X_L = 2\pi fL$$

$$X_L = 0$$

Since the reactance offered by the inductor is 0, hence the circuit acts as a short circuit.

150. Answer: a

Explanation:

OP-AMP as an integrator

A capacitor present in the feedback path of the OP-AMP makes it work like an integrator.

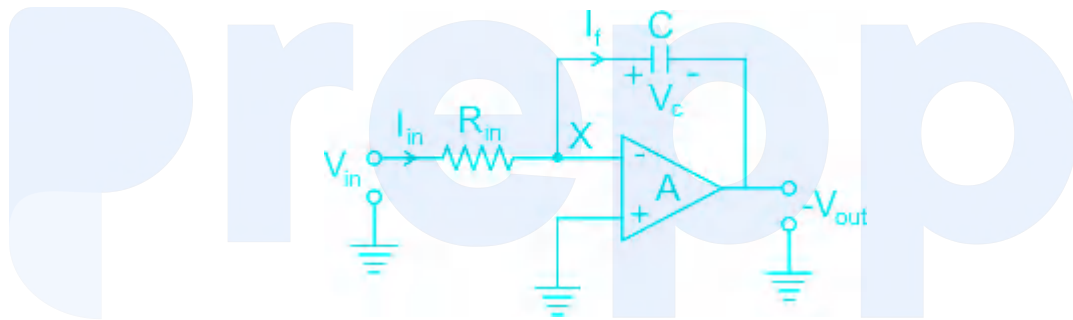

The transfer of the inverting OP-AMP is given by:

$$\frac{V_o(s)}{V_{in}(s)} = -\frac{Z_2}{Z_1}$$

$$\frac{V_o(s)}{V_{in}(s)} = -\frac{1/sC}{R_{in}}$$

$$\frac{V_o(s)}{V_{in}(s)} = -\frac{1}{sR_{in}C}$$

$$\therefore \frac{1}{s} = \int dt$$

$$V_o(t) = -\frac{1}{R_{in}C} \int V_{in}(t) dt$$

151. Answer: a

Explanation:

The device that is used for converting continuous DC to discontinuous DC is known as a chopper.

If the output DC is greater than the input DC, it is known as the step-up chopper.

If the output DC is smaller than the input DC, it is known as the step-down chopper.

Types of power electronic devices

Conversion	Device
AC to DC	Rectifier
AC to AC	Cyclo converter
DC to AC	Inverter
DC to AC	Chopper

★ Additional Information

- **Oscillator:** It is a circuit that produces a continuous, repeated, alternating waveform without any input.
- **Amplifier:** It is an electronic device that increases the magnitude or power of the input signal

152. Answer: c

Explanation:

Clipper circuit

Clipper circuits are the circuits that clip off or remove a portion of an input signal, without causing any distortion to the remaining part of the waveform.

It is also known as the limiter circuit.

Clippers are basically classified into the following categories:

Clamper circuit

A Clamper circuit is used for adding a DC shift to an AC signal. It does not distort the shape of the signal but only shifts the amplitude of the signal.

It is also known as the DC adder or DC inserter circuit.

★ Additional Information

Series positive clipper

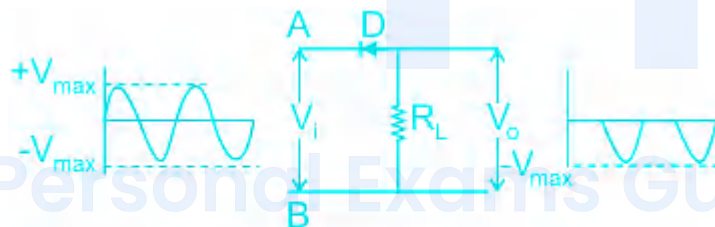

Series Positive Clipper

Series negative clipper

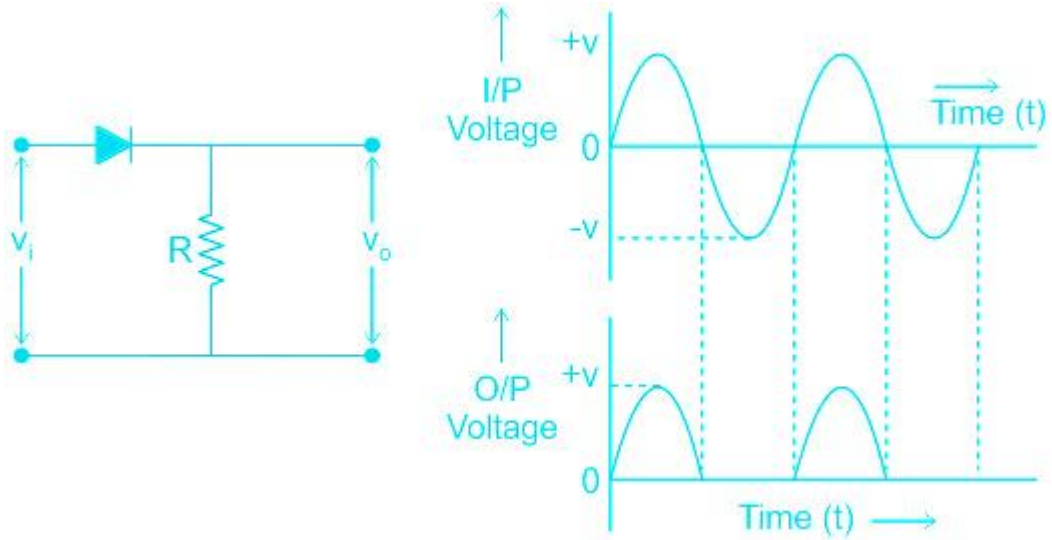

Parallel positive clipper

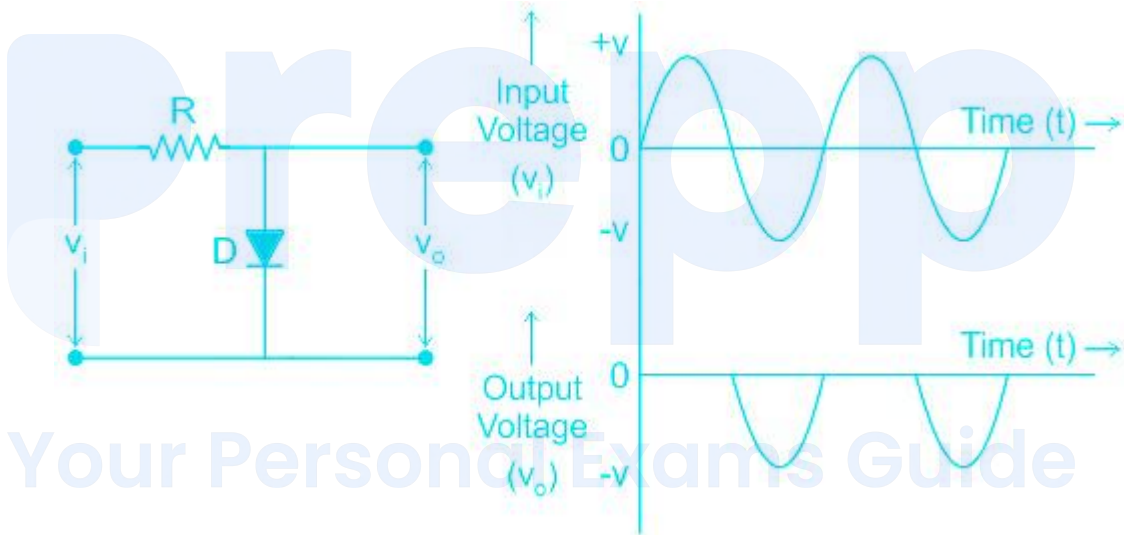

Parallel negative clipper

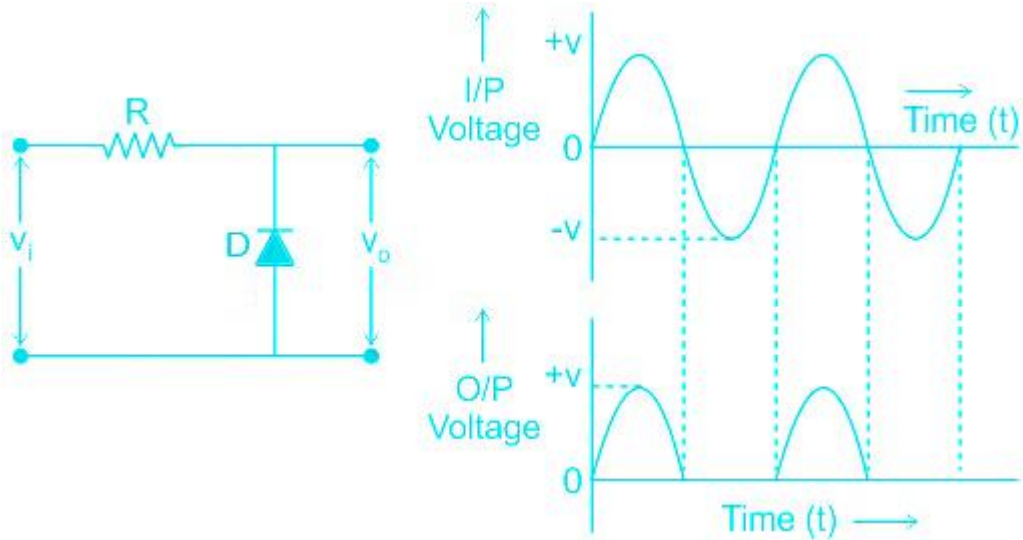

153. Answer: b

Explanation:

Connection of PN junction diode

A diode can be connected in two ways:

1.) Forward biasing

A diode is said to be forward-biased if the positive terminal of the battery is connected to the anode and the negative terminal of the battery is connected to the cathode.

The forward bias diode works like a closed switch and allows the current through itself.

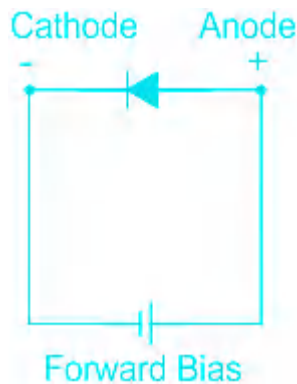

2.) Reverse biasing

A diode is said to be reverse-biased if the positive terminal of the battery is connected to the cathode and the negative terminal of the battery is connected to the anode.

The reverse bias diode blocks the current passage and works as an open switch.

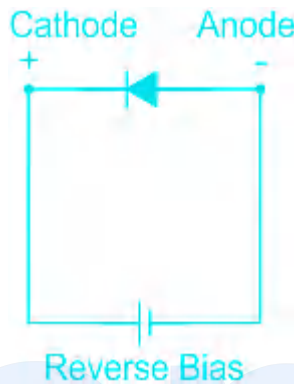

154. Answer: b

Explanation:

IC 555 timer

The 555 timer IC is used for the pulse generation.

The 555 timer IC is an integrated circuit used in a variety of timer, pulse generation, and oscillator applications.

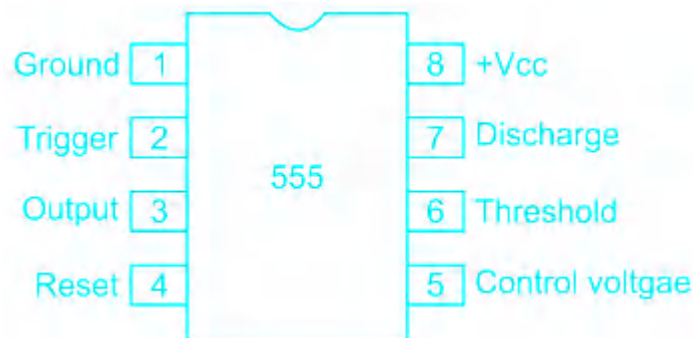

It has three operating modes:

- 1.) **Astable mode:** In this mode, the 555 IC can be used as an oscillator, pulse generator, logic clocks, etc.
- 2.) **Monostable mode:** In this mode, the 555 functions as a one-shot pulse generator and find uses in frequency divider, timers and pulse detection.
- 3.) **Bistable mode:** In this mode, the 555 IC can be operated as latches and flip-flops.

155. Answer: d

Explanation:

Fiber optic cable

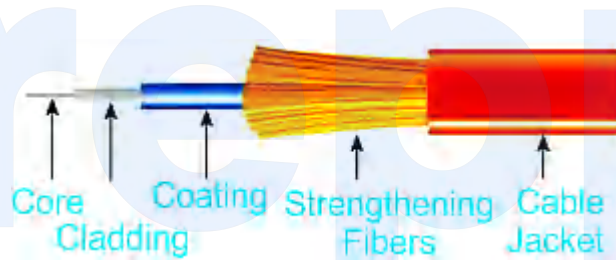

A fiber optic cable consists of five main components: core, cladding, coating, strengthening fibers, and cable jacket.

1.) Core

- The core of the fiber cable is made up of glass.
- This is the physical medium that transports optical signals from an attached light source to a receiving device.
- The core is a single continuous strand of high-purity glass or plastic whose diameter is measured in microns.
- The larger the core, the more light the cable can carry, which correlates to a higher data transfer rate.

2.) Cladding

- This is a thin layer that is extruded over the core and serves as the boundary that contains the light waves, enabling data to travel through the length of the

fiber.

3.) Coating

- This is a plastic coating over the cladding to reinforce the fiber core, help absorb shocks, and provide extra protection against excessive cable bends.
- It does not have any effect on the optical waveguide properties.

4.) Strengthening fibers

- These components help protect the core against crushing forces and excessive tension during installation.
- The materials can range from Kevlar, to wire strands, to gel-filled sleeves.
- Sometimes light-absorbing (“dark”) glass is added between the fibers, to prevent light that leaks out of one fiber from entering another. This reduces cross-talk between the fibers.

5.) Cable jacket

- This is the outer layer, or sheathing, of the cable.
- Its purpose is to protect the cable from environmental hazards, such as construction work, fishing gear, and even sharks, which are often attracted to the electrical fields created by signal conductors to repeaters.

Your Personal Exams Guide

156. **Answer: b**

Explanation:

Fibre light source

A fiber light source is used to inject light into a fiber optic cable for the purpose of testing it.

In fiber optics, Laser and LED are used as a light sources to emit electromagnetic radiation.

1.) Light emitting diode (LED)

- LEDs are low cost, slower speed, easy to use, multimode-only, and have a wide output pattern.
- Because LEDs produce less concentrated light than lasers and have a much lower power output than lasers, they're difficult to couple into fibers, limiting them to multimode fibers.
- LEDs have less bandwidth than lasers and can achieve a maximum throughput of 1 Gbps.

2.) Laser diode

- Laser diodes are higher cost and faster speed, allow single-mode or multimode and have a narrow output pattern.
- Lasers can achieve throughput up to and beyond 10 Gbps.

157. Answer: d

Explanation:

BC 194 is the transistor used for the amplification of RF signals.

Types of amplifiers

1.) Radio-frequency (RF) amplifier

- RF amplifiers are radio frequency amplifiers.
- They increase the amplitude of radio frequency waves. 20kHz to 300GHz. These are found in satellites, cell phone towers, and in dish antennas.

2.) Audio-frequency (AF) amplifier

- AF amplifiers are audio frequency amplifiers.
- They increase the amplitude of waves from 20Hz to 20kHz.
- These are widely used in speakers, microphones, earphones, etc

158. Answer: a

Explanation:

Counter/Timers in 8051 microcontroller

- 8051 microcontrollers have two timers: timer0 and timer1 which work on the clock frequency.
- They can be used either as timers or as counters.
- A timer/counter can be used for time delay generation, counting external events, etc.
- Every Timer needs a clock to work, and 8051 provides it from an external crystal which is the main clock source for Timer.
- The internal circuitry in the 8051 microcontrollers provides a clock source to the timers which are 1/12th of the frequency of the crystal attached to the microcontroller.

159. Answer: a

Explanation:

Concept

The frequency of the rotor current in an induction motor is given by:

$$f_r = sf_s$$

where, f_r = Rotor frequency

f_s = Supply frequency

s = Slip

The slip of the induction motor is given by:

$$s = \frac{N_s - N_r}{N_s}$$

where, N_s = Synchronous speed

N_r = Rotor speed

160. Answer: a

Explanation:

Amplifier

An amplifier is an electronic device that increases the voltage, current, or power of a signal.

The voltage gain of the amplifier is given by:

$$A_v = \frac{V_o}{V_i}$$

where, A_v = Voltage gain

V_o = Output voltage

V_i = Input voltage

Explanation

If the voltage gain of the amplifier is unity i.e. $A_v = 1$, then

$$1 = \frac{V_o}{V_i}$$

$$V_o = V_i$$

For unity gain, the output voltage is equal to the input voltage, hence unity gain amplifier is also known as the voltage follower circuit.

161. Answer: b

Explanation:

Resistance Temperature Detector (RTD)

- A Resistance Temperature Detector is an electronic device used to determine the temperature by measuring the resistance of an electrical wire.
- This wire is referred to as a temperature sensor.
- For the measurement of temperature with high accuracy, an RTD is used because it has good linear characteristics over a wide range of temperatures.
- Copper, Nickel, and Platinum are widely used metals for RTDs.
- RTD has a positive temperature coefficient of resistance.
- Therefore, the resistance of an RTD increases with an increase in temperature.

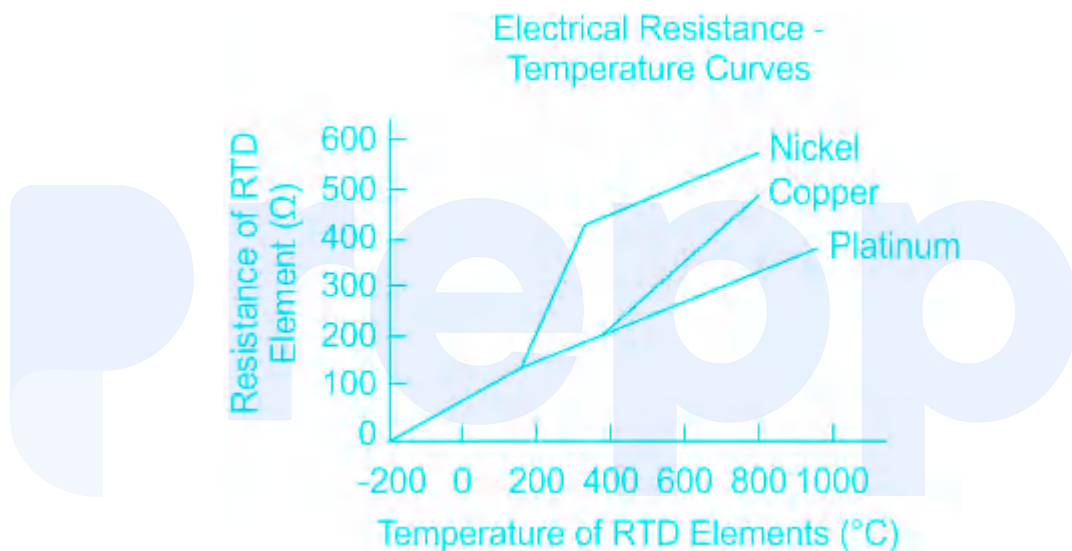

Your Personal Exams Guide

162. Answer: a

Explanation:

Register

A Register is a collection of flip-flops.

A flip-flop is used to store single-bit digital data. For storing a large number of bits, the storage capacity is increased by grouping more than one flip-flop. or storing n-bit words, an n-bit register containing n number of flip-flops is used.

1-bit register consists of 1 flip-flop. Therefore, 16-bit registers consist of 16 flip-flops.

There are the following operations which are performed by the registers:

1.) Fetch

- To take the instructions given by the users.
- To fetch the instruction stored in the main memory.

2.) Decode

The decode operation is used to interpret the instructions. In decoding, the operation performed on the instructions is identified by the CPU.

3.) Execute

The execution operation is used to store the result produced by the CPU in the memory. After storing this result, it is displayed on the user screen.

163. Answer: b

Explanation:

Connection of cells

1.) Series connection

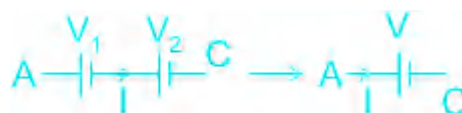

The current remains the same and the total current in the connection is equal to the current through each cell.

The total voltage across the combination is the sum of the voltage across each cell, hence the voltage increases.

2.) Parallel connection

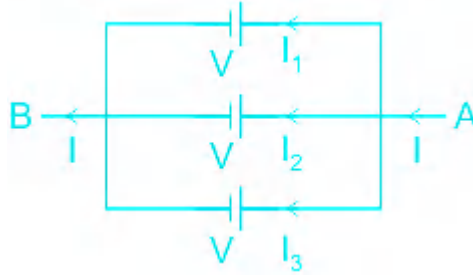

The voltage remains the same and the total voltage across the connection is equal to the voltage across each cell.

The total current across the combination is the sum of the current across each cell, hence the current increases.

164. Answer: a

Explanation:

Half adder

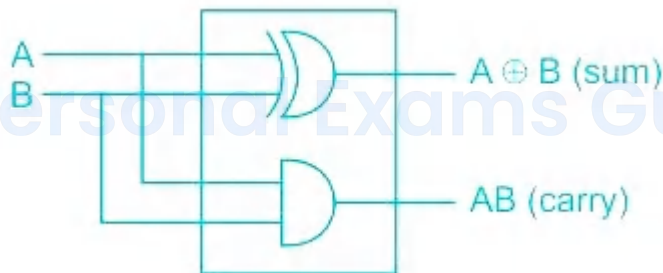

The half adder is a type of combinational logic circuit that adds two 1-bit binary numbers.

It generates the carry and sum of both inputs.

A	B	Sum	Carry
0	0	0	0
0	1	1	0
1	0	1	0
1	1	0	1

Sum = $A \oplus B$

Carry = AB

Full adder

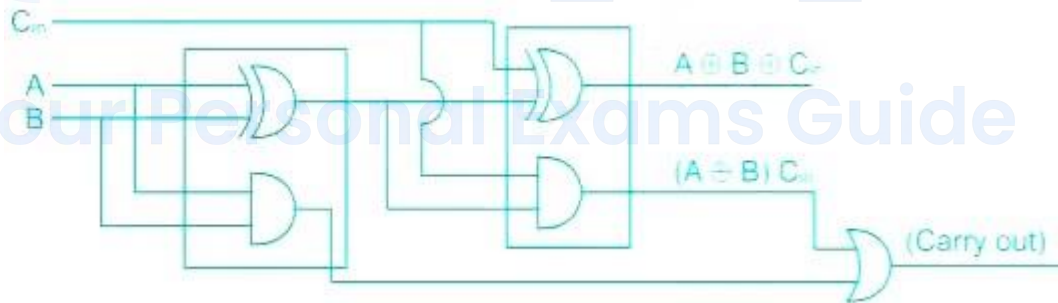

The full adder is a type of combinational logic circuit that adds three 1-bit binary numbers.

The full adder is the combination of two half adders.

A	B	C in	Sum	C out
0	0	0	0	0
0	0	1	1	0
0	1	0	1	0
0	1	1	0	1
1	0	0	1	0
1	0	1	0	1
1	1	0	0	1
1	1	1	1	1

$$\text{Sum} = A \otimes B \otimes C \text{ in}$$

$$C \text{ out} = AB + BC \text{ in} + C \text{ in} A$$

165. Answer: b

Explanation:

Parameters of sine wave

1.) Average value

$$V_{avg} = \frac{2V_m}{\pi}$$

$$V_{avg} = 0.637V_m$$

The average value of the sine wave is 0.637 times the peak value.

2.) RMS value

$$V_{RMS} = \frac{V_m}{\sqrt{2}}$$

$$V_{RMS} = 0.707V_m$$

The RMS value of the sine wave is 0.707 times the peak value.

3.) Form factor

$$FF = \frac{V_{RMS}}{V_{avg}}$$

$$FF = \frac{0.707V_m}{0.637V_m}$$

$$FF = 1.11$$

4.) Crest factor

$$CF = \frac{V_p}{V_{RMS}}$$

$$CF = \frac{V_m}{0.707V_m}$$

$$CF = 1.414$$

166. Answer: d

Explanation:

Symbols of different antennas

1.) Yagi antenna

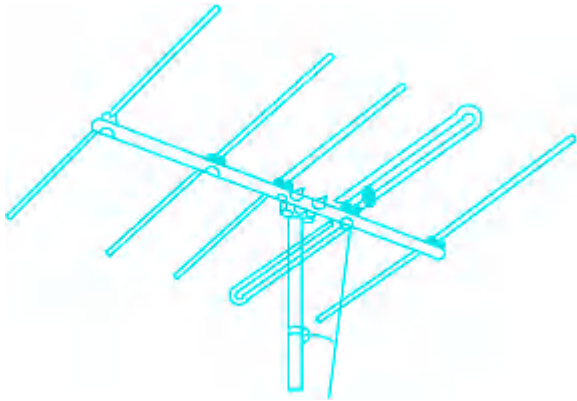

2.) Circular antenna



3.) Bi-pole antenna

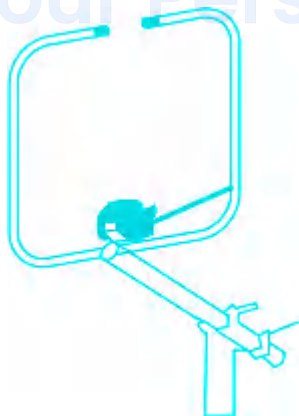

4.) Monopole antenna

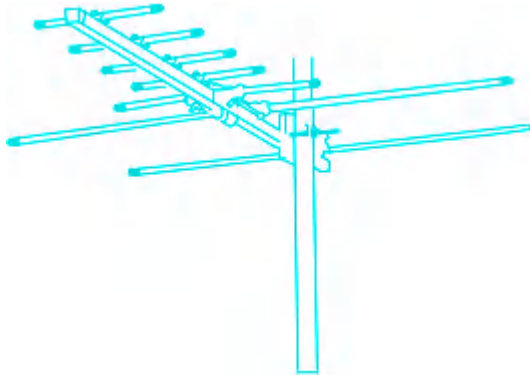

167. Answer: b

Explanation:

Parameters of sine wave

1.) Average value

The average of all the instantaneous values of an alternating voltage and current over one complete cycle is known as an average value.

$$V_{avg} = \frac{2V_m}{\pi}$$

$$V_{avg} = 0.637V_m$$

The average value of the sine wave is 0.637 times the peak value.

2.) RMS value

The 'RMS Value' stands for Root Mean Squared value.

The RMS value of an alternating current is given by that steady (D.C) current which when flowing through a given time produces the same amount of heat as produced by the A.C when flowing through the same circuit for the same time.

$$V_{RMS} = \frac{V_m}{\sqrt{2}}$$

$$V_{RMS} = 0.707V_m$$

The RMS value of the sine wave is 0.707 times the peak value.

3.) Form factor

The ratio of the RMS value to the average value is known as the form factor.

$$FF = \frac{V_{RMS}}{V_{avg}}$$

$$FF = \frac{0.707V_m}{0.637V_m}$$

$$FF = 1.11$$

4.) Crest factor

The ratio of the maximum value (peak value) to the RMS value is known as the peak factor or crest factor.

$$CF = \frac{V_p}{V_{RMS}}$$

$$CF = \frac{V_m}{0.707V_m}$$

$$CF = 1.414$$

168. Answer: b

Explanation:

Symbols of fuse

There are different symbols of fuse as per different standards.

1.) IEEE / ANSI standard



2.) IEC standard

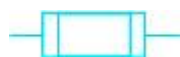

3.) Old standard



169. Answer: b

Explanation:

Concept

The power factor is defined as the cosine of the angle between voltage and current.

$$\text{Power factor} = \cos\phi$$

Power factor is also defined as the ratio of active and apparent power.

$$\cos\phi = \frac{P}{S}$$

Explanation

For a DC circuit, the voltage and current remain in the same phase, hence the angle between them is zero.

$$\text{Power factor} = \cos\phi$$

$$\cos\phi = \cos 0^\circ = 1$$

$$\cos\phi = \text{unity}$$

170. Answer: a

Explanation:

Oscillators

An oscillator is a circuit that produces a continuous, repeated, alternating waveform without any input.

Oscillators basically convert unidirectional current flow from a DC source into an alternating waveform.

In simple oscillators, UJTs are used.

UJT Relaxation Oscillator is used as a pulse generator when the voltage across the discharge resistor is used.

Oscillators work on positive feedback and follow Barkhausen's criteria.

The Barkhausen stability criterion is a mathematical condition to determine when a linear electronic circuit will oscillate or not. It will oscillate when:

- The loop gain must be unity.
- The phase shift through the loop is either zero or an integer multiple of 2π .

171. Answer: d

Explanation:

Linear Variable Differential Transformer (LVDT)

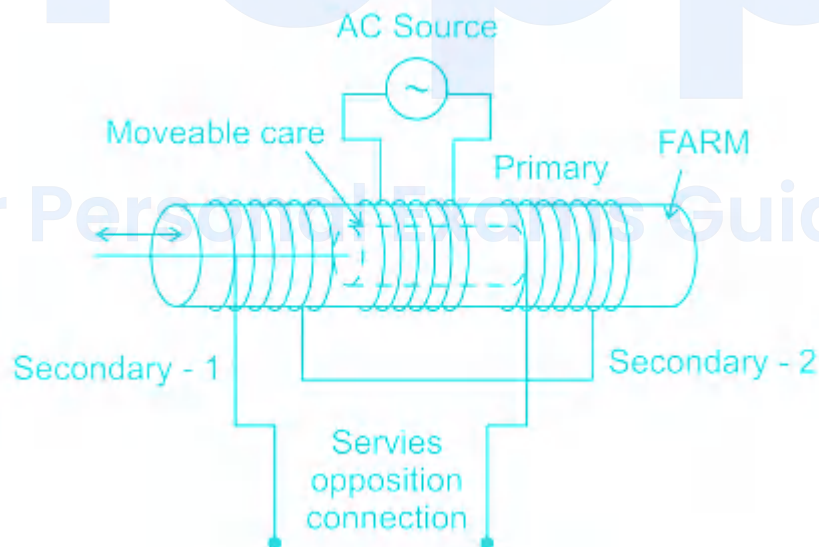

- These devices are used to measure displacement.
- It is the most widely used inductive transducer that converts linear motion into an electrical signal.
- The LVDT is placed inside a stainless steel housing because it will provide electrostatic and electromagnetic shielding.

- LVDTs operate on the principle of a transformer.
- The transformer consists of a primary winding and two secondary windings wound on a cylindrical former.
- Both the secondary windings have an equal number of turns, and we place them on either side of the primary winding.
- The primary winding is connected to an AC source which produces a flux in the air gap and voltages are induced in secondary windings.
- A movable soft iron core is placed inside the former and the displacement to be measured is connected to the iron core.
- Both the secondary windings are connected in such a way that resulted in output is the difference between the voltages of the two windings.

172. Answer: c

Explanation:

Open and closed system

The system without any feedback is known as the open loop system and the gain of such a system is known as the open loop gain.



The open loop gain is given by:

$$\frac{Y(s)}{R(s)} = G(s)$$

The system with feedback is known as the closed-loop system and the gain of such a system is known as the closed-loop gain.



The closed loop gain is given by:

$$\frac{C(s)}{R(s)} = \frac{G(s)}{1+G(s)H(s)}$$

173. Answer: a

Explanation:

Load line of transistor

If this load line is drawn only when DC biasing is given to the transistor, but no input signal is applied, then such a load line is called as DC load line.

The load line is drawn under the conditions when an input signal along with the DC voltages are applied, such a line is called an AC load line.

Common Emitter Transistor

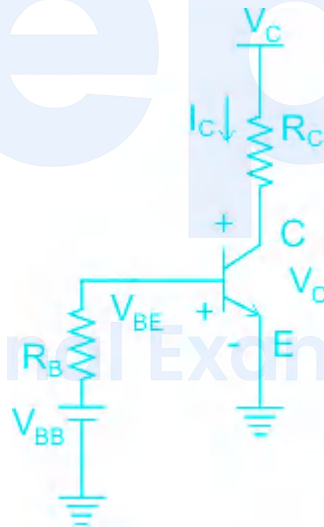

In the common-emitter transistor, the emitter is grounded and the input is given to the base, and the output is taken from the collector.

In this configuration, the load line is plotted between the output voltage and output current for increasing the value of the input current.

The output voltage is V_{CE} , the output current is I_C , and the input current is I_B .

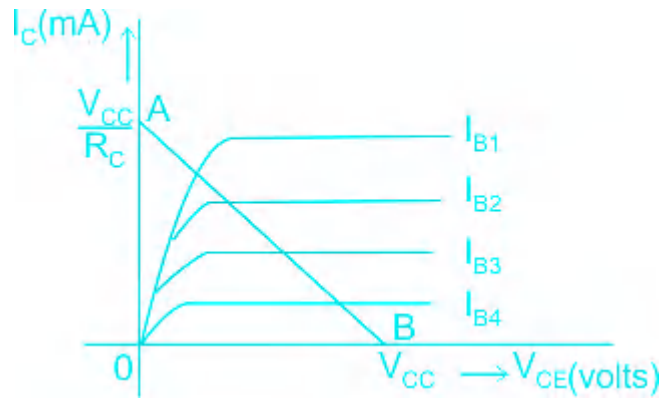

174. Answer: b

Explanation:

Kirchhoff's circuit laws

1.) Kirchhoff's current law (KCL)

It states that the total current entering a junction is equal to the total current leaving the node.

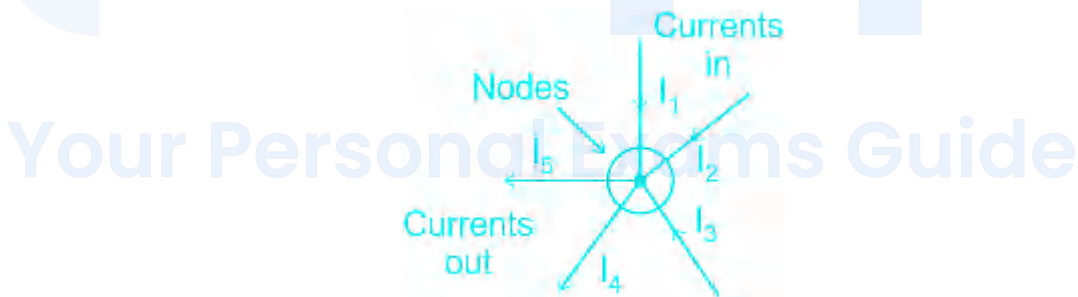

Incoming current = Outgoing current

$$I_1 + I_2 + I_3 = I_4 + I_5$$

2.) Kirchhoff's current law (KVL)

It states that the sum of the total voltage drop in a closed loop is equal to zero.

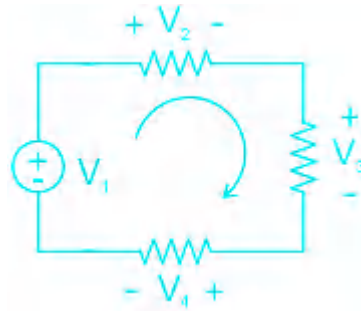

$$-V_1 + V_2 + V_3 + V_4 = 0$$

$$V_1 = V_2 + V_3 + V_4$$

175. Answer: a

Explanation:

A higher voltage is obtained from a solar cell by connecting multiple cells in series.

Connection of cells

1.) Series connection

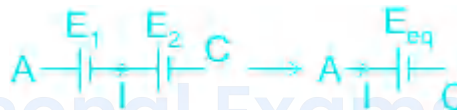

The current remains the same and the total current in the connection is equal to the current through each cell.

The total voltage across the combination is the sum of the voltage across each cell, hence the voltage increases.

2.) Parallel connection

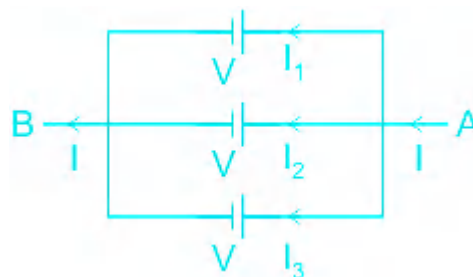

The voltage remains the same and the total voltage across the connection is equal to the voltage across each cell.

The total current across the combination is the sum of the current across each cell, hence the current increases.

prepp

Your Personal Exams Guide