

## RRB NTPC 28 Dec 2020 Shift 1 Solution

---

**Que. 1**

**Which of the following Articles includes provision for Election commission?**

- 1. Article 324**
- 2. Article 143**
- 3. Article 243**
- 4. Article 233**

**Ans.** Correct Option - 1

The correct answer is option 1 i.e., Article 324.

Article 324 includes provision for Election commission.

Articles 324(1) states that the superintendence, direction, and control of the preparation of the electoral rolls for, and the conduct of, all elections to Parliament and to the Legislature of every State and of elections to the offices of President and Vice-President held under this Constitution shall be vested in Commission.

Article 324(2) states that The Election Commission shall consist of the Chief Election Commissioneranda such number of other Election Commissioners.

Article 143 includes provision for the Power of President to consult the Supreme Court.

**Que. 2**

**If  $\cos\theta = 3/5$ , then find the value of  $\tan\theta$ .**

- 1.  $4/5$**
- 2.  $4/3$**
- 3.  $3/4$**
- 4.  $5/4$**

**Ans.** Given:

Correct Option - 2

$$\cos\theta = 3/5$$

Concept used:

In a right-angled triangle

$$\cos\theta = \text{base/hypotenuse}$$

$$\tan\theta = \text{perpendicular/base}$$

Pythagoras theorem

$$(\text{Hypotenuse})^2 = (\text{Perpendicular})^2 + (\text{Base})^2$$

Calculation:

$$\text{Base} = 3, \text{Hypotenuse} = 5$$

By using pythagoras theorem

$$\Rightarrow (\text{Perpendicular})^2 = (5)^2 - (3)^2$$

$$\Rightarrow (\text{Perpendicular})^2 = 25 - 9$$

$$\Rightarrow (\text{Perpendicular})^2 = 16$$

$$\Rightarrow \text{Perpendicular} = 4$$

$$\tan\theta = \text{perpendicular}/\text{base}$$

$$\Rightarrow \tan\theta = 4/3$$

$\therefore$  The value of  $\tan\theta$  is  $4/3$ .

**Que. 3 Direction:** Read the following information and answer the following question. Six people P, Q, R, S, T and U are sitting in a row facing to the north. P and Q are sitting on the extreme ends of the row. T is sitting second to the right of the Q. There are two persons are sitting between U and R. P is sitting immediately to the right of R.

**Who is sitting third to the left of S?**

1. Q
2. R
3. U
4. P

**Ans.**

Correct Option - 1

Given,

Six people P, Q, R, S, T and U are sitting in a row facing to the north.

1) P and Q are sitting on the extreme ends of the row.

2) T is sitting second to the right of the Q.



3) There are two persons are sitting between U and R.

4) P is sitting immediate right of R. so the final arrangement is :



Q is sitting third to the left of S.

Hence, 'Q' is the correct answer.

**Que. 4**

**Where is the Gobi Desert located?**

- 1. Botswana**
- 2. Turkmenistan**
- 3. Mongolia**
- 4. Antarctica**

**Ans.** Correct Option - 3

The Gobi Desert is located in Mongolia.

It is overall a cold desert.

It is famous for its dinosaur fossil treasures.

The area covered by Gobi Desert is 1.295 million km<sup>2</sup>.

Botswana - Kalahari Desert

Turkmenistan - Karakum Desert, Kyzylkum Desert

Antarctica - Antarctica Desert

**Que. 5**

**If the simple interest for 2 years is Rs. 500 at 10% rate of interest. Find the compound interest for the same time.**

- 1. Rs. 525**
- 2. Rs. 500**
- 3. Rs. 200**
- 4. Rs. 210**

**Ans.** Given: Correct Option - 1

Time = 2 years, Simple Interest = 500, rate = 10%

Formula used:

Simple Interest = (Principal × Rate × Time)/100

Compound Interest = Principal[(1 + rate/100)<sup>2</sup> – 1]

Calculation:

Let the principal be 'P'.

Simple Interest = (Principal × Rate × Time)/100

⇒ 500 = (Principal × 10 × 2)/100

⇒ Principal = 2500

Compound Interest = Principal[(1 + rate/100)<sup>2</sup> – 1]

⇒ 2500[(1 + 10/100)<sup>2</sup> – 1]

⇒ 525

∴ The compound Interest is Rs 525.

**Que. 6**

**How many person/s sitting between T and P?**

- 1. One**
- 2. Three**
- 3. Two**
- 4. None**

**Ans.**

Correct Option - 3

Given,

Six people P, Q, R, S, T and U are sitting in a row facing to the north.

- 1) P and Q are sitting on the extreme ends of the row.
- 2) T is sitting second to the right of the Q.



- 3) There are two persons are sitting between U and R.
- 4) P is sitting immediate right of R. so the final arrangement is :



Two-person are placed between T and P.

Hence, 'Two' is the correct answer.

**Que. 7**

**'Saddle Peak' the highest peak of Andaman and Nicobar Islands is located in .**

- 1. Great Nicobar**
- 2. Middle Andaman**
- 3. Little Andaman**
- 4. North Andaman**

**Ans.** Correct Option - 4

'Saddle Peak' the highest peak of Andaman and Nicobar Islands is located in Diglipur, a town in North Andaman Island.

It is the highest point of the archipelago in the Bay of Bengal with a length of 731 meters (2,418feet) followed by Mount Thuillier at 2,106 feet (642 meters) on Great Nicobar and Mount Harriet at 1,197feet(365 meters) on South Andaman.  
It is surrounded by Saddle Peak National Park.

**Que. 8**

**If  $x + y = 12$ ,  $y + z = 15$  and  $x + z = 18$ , then find  $x + y + z = ?$**

1. 18
2. 12
3. 15
4. 22.5

**Ans.** Given: Correct Option - 4

$$x + y = 12, y + z = 15, x + z = 18$$

Calculation:

$$x + y = 12 \text{----- (1)}$$

$$y + z = 15 \text{----- (2)}$$

$$x + z = 18 \text{----- (3)}$$

By solving equations (1) and (2)

$$\Rightarrow x - z = -3 \text{----- (4)}$$

By solving equations (3) and (4)

$$\Rightarrow x = 7.5$$

Put the value of x in equation (1)

$$\Rightarrow y = 4.5$$

Put the value of y in equation (2)

$$\Rightarrow z = 10.5$$

$$x + y + z$$

$$\Rightarrow 7.5 + 4.5 + 10.5$$

$$\Rightarrow 22.5$$

$\therefore$  The value of  $x + y + z$  is 22.5.

**Que. 9 Direction: Read the following information carefully and answer the following question.**

**P is the mother of Q, Q is the sister of Y, Y is the husband of E, F is the son of Y, G is the brother of E and N is the father of G.**

**How P related to E?**

1. Sister
2. Mother- in- law
3. Brother
4. Father

**Ans.** Correct Option - 2

Preparing the family tree using the following symbols,

Symbol in Diagram	Meaning
○	Female
□	Male
==	Married couple
—	Siblings
	Difference of a generation

1. P is the mother of Q, Q is the sister of Y.

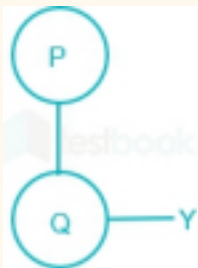

2. Y is the husband of E, F is the son of Y.

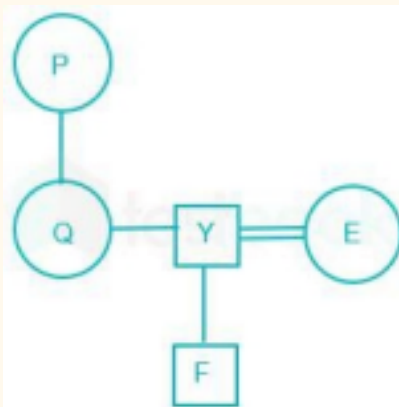

3. G is the brother of E and N is the father of G. So the final family diagram is:

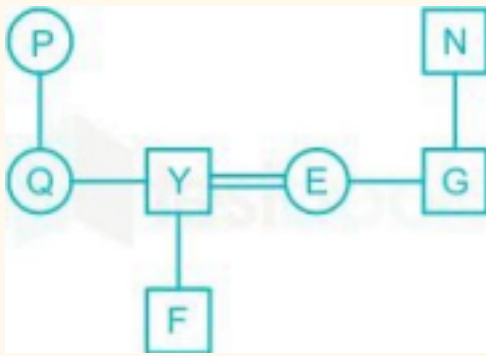

So, P is Mother - in - law of E.

Hence, 'Mother- in - law' is the correct answer.

**Que. 10**

**On which day is Earth Day celebrated?**

1. 17 April
2. 27 March
3. 22 May
4. 22 April

**Ans.** Correct Option - 4

The correct answer is April 22.

Earth Day is celebrated on April 22 every year to demonstrate support for environmental protection.

The year 2020 marks the 50th anniversary of the annual celebrations.

The theme for Earth Day 2020 is 'Climate Action'.

Earth Day 2020 calls for 24 hours of actions, big and small, for people and the planet.

**Que. 11 Length of rectangle is twice its breadth, if perimeter of the rectangle is 78 m, then what will be the area of the rectangle?**

1. 300 m<sup>2</sup>
2. 338 m<sup>2</sup>
3. 169 m<sup>2</sup>
4. 507 m<sup>2</sup>

**Ans.** Given: Correct Option - 2

Length of rectangle = 2 × Breadth

Perimeter = 78 m

Formula used:

Perimeter = 2 × (L + B)

Area = L × B

Where L is length and B is the breadth

Calculation:

Let the breadth of the rectangle be  $x$  m and the length of the rectangle be  $2x$  m Perimeter =

$$2 \times (2x + x) = 6x$$

$$\Rightarrow 78 = 6x$$

$$\Rightarrow x = 13 \text{ m}$$

Length =  $2 \times 13 = 26$  m and Breadth = 13 m

$$\text{Area} = L \times B$$

$$\Rightarrow \text{Area} = 13 \times 26$$

$\therefore$  Area of rectangle is  $338 \text{ m}^2$

**Que. 12**

**How G related to Y ?**

1. Sister- in - law
2. Brother- in- law
3. Father
4. Brother

**Ans.** Correct Option - 2

Preparing the family tree using the following symbols,

Symbol in Diagram	Meaning
○	Female
□	Male
══	Married couple
—	Siblings
	Difference of a generation

1.P is the mother of Q, Q is the sister of Y.

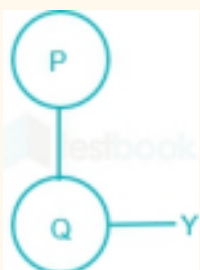



2. Y is the husband of E, F is the son of Y.

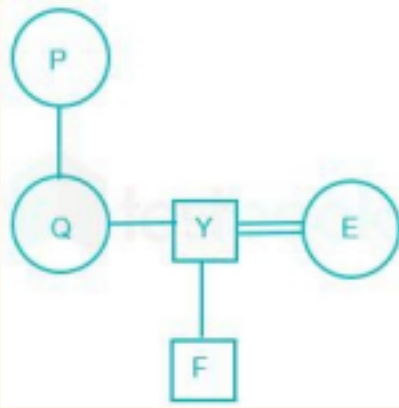

3. G is the brother of E and N is the father of G. So the final family diagram is:

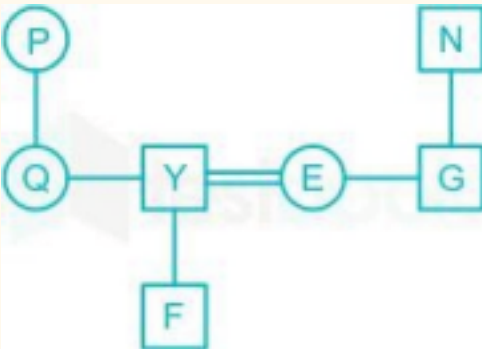

So, G is the brother - in - law of Y.

Hence, 'Brother - in -law' is the correct answer.

**Que. 13 What is the SI unit of electric resistance?**

1. Volt
2. Ampere
3. Ohm
4. Joules

**Ans.** Correct Option - 3 CONCEPT:

Resistance: The property of any conductor that opposes the flow of electric current through it is called resistance.

It is denoted by R and the SI unit is the ohm ( $\Omega$ ).

**Que. 14 Curved surface area of a cylinder is  $308 \text{ cm}^2$ , and height is 14 cm. What will be the volume of the cylinder?**

1.  $1.439 \text{ cm}^3$
2.  $2.385 \text{ cm}^3$
3.  $3.539 \text{ cm}^3$
4.  $4.529 \text{ cm}^3$

**Ans.** Given: Correct Option - 3

Curved surface area of cylinder = 308 cm

Height = 14 cm

Formula used:

CSA (Curved surface area) =  $2\pi rh$

Volume =  $\pi r^2 h$

Where r is radius and h is height

Calculation:

CSA =  $2\pi rh$

$308 = 2 \times (22/7) \times r \times 14$

$\Rightarrow 308 = 88r$

$\Rightarrow r = 7/2 = 3.5$  cm

Volume =  $\pi r^2 h$

$\Rightarrow$  Volume =  $(22/7) \times (3.5)^2 \times 14$

$\Rightarrow$  Volume =  $539$  cm<sup>3</sup>

$\therefore$  Volume of the cylinder is  $539$  cm<sup>3</sup>

**Que. 15**

In a certain code language, "ROLL" is written as "SQOP" and "POLE" is written as "QQOI".

How is "PAGE" is written in that code language

1. QCIJ

2. QJCI

3. JQCI

4. QCJI

**Ans.** Correct Option - 4

The pattern followed here is:

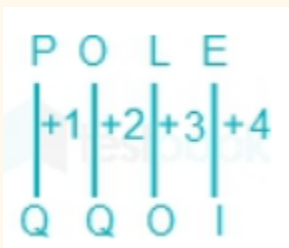
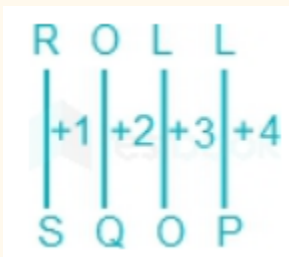

Similarly,

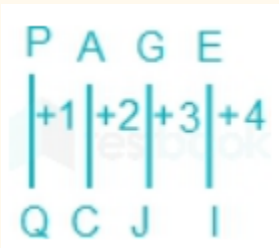

Hence, 'QCJI' is the correct answer.

**Que. 16**

**How many Ramsar Sites have been declared so far in India?**

1. 36
2. 37
3. 42
4. 43

**Ans.** Correct Option - 3

The correct answer is 42.

India has added Tso Kar Wetland Complex in Ladakh as its 42nd Ramsar site. It is also a second one in the Union Territory (UT) of Ladakh.

**Que. 17**

**By how much percentage 700 has to be increased to make it 840?**

1. 16.67%
2. 20%
3. 8.33%
4. 120%

**Ans.** Correct Option - 2

Given:

Old number = 700

New number = 840

Formula used:

Percentage increase =  $\frac{\text{New number} - \text{Old number}}{\text{Old number}} \times 100$

Calculations:

Percentage increase =  $\frac{(840 - 700)}{700} \times 100$

$\Rightarrow (140/700) \times 100$

$\Rightarrow 20\%$

$\therefore$  By 20%, 700 has to be increased make it 840.

**Que. 18** A series is given with one term missing. Select the correct alternative from the given ones that will complete the series.

A, D, G, J, ?

1. M
2. L
3. O
4. N

**Ans.** Correct Option - 1

Logic: Each letter is increased by 3 from its positional value to get the next term of the series. The pattern followed here is :



Hence, 'M' is the correct answer.

**Que. 19**

The ancient Indian text 'Rajatarangini' is a composition of:

1. Bilhana
2. Kalhana
3. Banabhatta
4. Sandhyakar Nandi

**Ans.** Correct Option - 2

The ancient Indian text 'Rajatarangini' is a composition of Kalhana.

Rajatarangini is written in Sanskrit verse by the Kashmiri Brahmin Kalhana in 1148.

It covers the whole span of history in the Kashmir region from the earliest instances to the date of its composition.

**Que. 20**

The MP of an item is 75% more than its CP and if 15% discount is given then what is the profit%?

1. 50%
2. 48.25%
3. 48%
4. 48.75%

**Ans.** Given: Correct Option - 4

Discount, (D) = 15%

Formula used:

$$MP/CP = (100 + P\%)/(100 - D\%)$$

Here, P and D is profit and discount respectively

$$SP = (100 - D\%)/100 \times MP$$

Profit = Selling price (SP) – cost price (CP)

$$\text{Profit \%} = \text{Profit}/CP \times 100$$

Concept used:

Discount is given on marked price

Calculation:

Let the cost price of the item be 100x

$$MP = 100x + 75\% \text{ of } 100x = 175x$$

$$SP = (100 - D\%)/100 \times MP$$

$$\Rightarrow (100 - 15)/100 \times 175x$$

$$\Rightarrow 85/100 \times 175x$$

$$\Rightarrow 148.75x$$

$$\text{Profit} = 148.75x - 100x = 48.75x$$

$$\text{Profit \%} = 48.75x/100x \times 100 = 48.75$$

∴ The Profit percentage is 48.75%

**Que. 21** Select the option that can replace the question mark (?) and complete the given series. 18, 21, 26, 33, 42, ?, ?

1. 65, 83

2. 52,64

3. 53, 66

4. 65,74

**Ans.** Correct Option - 3

Logic: Each term is increased by odd number successively start from 3

The pattern followed here is :



Hence, '53,66' is the correct answer.

**Que. 21 Which of the following recipients name is announced for 55<sup>th</sup> Jnanpith Award?**

- 1. Nasira Sharma**
- 2. Vasdev Mohi**
- 3. Shri Akkitham**
- 4. None of the above**

**Ans.** Correct Option - 3

Option 3 is correct, i.e. Shri Akkitham.

Shri Akkitham is a Malayalam language writer whose name announced for the 55<sup>th</sup> Jnanpith Award for the year 2019.

Vasdev Mohi is the Sindhi writer whose name was selected for Saraswati Samman 2019.

Nasira Sharma's name was selected for 2019 Vyas Samman.

**Que. 23 Three students A, B, and C gets 215, 105, and 202 marks in an exam respectively. Find the average marks of A, B, and C.**

- 1. 134**
- 2. 174**
- 3. 184**
- 4. 164**

**Ans.** Given:

Correct Option - 2

Marks of A = 215

Marks of B = 105

Marks of C = 202

Calculation:

$$\Rightarrow (215 + 105 + 202)/3$$

$$\Rightarrow 522/3$$

$$\Rightarrow 174$$

∴ The required result will be 174.

**Que. 24 Eight persons A, B, C, D, E, F, G and H are sitting around an octagonal table and facing towards the center. A is sitting third to the right of G and second to the left of C, B is diagonally opposite to A and sitting third to the right of E. F and D is an immediate neighbour of each other. D is sitting diagonally opposite to C. What is the position of H with respect to A?**

- 1. Third to the right**
- 2. Diagonally opposite**
- 3. Second to the left**

#### 4. Immediate right

**Ans.**

Correct Option - 1

Given,

Eight persons A, B, C, D, E, F, G and H are sitting around an octagonal table and faces towards the centre.

1) A is sitting third to the right of G and second to the left of C, B is diagonally opposite to A and sitting third to the right of E.

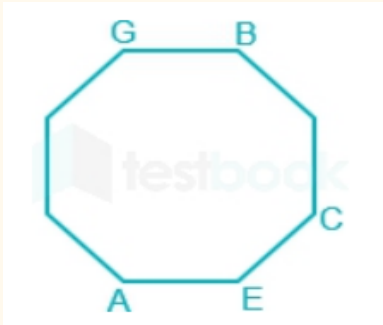

2) F and D is an immediate neighbour of each other. D is sitting diagonally opposite to C. So, the final arrangement is :

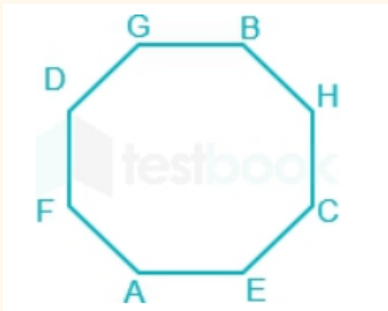

H is third to the right of A.

Hence, 'A' is the correct answer.

**Que. 25**

Weight of an object on the moon is \_\_\_\_\_ the weight of the object on earth.

1. equal to
2. 1/6th
3. 1/2
4. 1/5th

**Ans.** Correct Option - 2

The weight of an object depends on the value of  $g$ , i.e. acceleration due to gravity.  
Acceleration due to gravity of earth is 6 times the acceleration due to gravity of the moon.

The weight of an object on the moon is equal to  $1/6$ th of its weight on the Earth.

Weight = (mass)  $\times$  (acceleration due to gravity of planet)

At the surface of the earth

Weight =  $mg$

At the surface of Moon

Weight =  $mg / 6$

Acceleration due to Moon's gravity = (Acceleration due to Earth's gravity)/6

Weight on moon =  $1/6 \times$  Weight on earth

**Que. 26** The side of the square is increased by 20% then what is the % change in its area?

1. 54%
2. 34%
3. 52%
4. 44%

**Ans.** Correct Option - 4 Given:

Increase in side = 20%

Formula used:

Area of the square = side<sup>2</sup>

Concept used:

All the sides of the square is equal

Calculation:

Let the side of the square be  $l$

Area of the square =  $l^2$

After 20% increase,

Side of the square =  $l + 20\%$  of  $l = 1.2 l$

New area of the square =  $(1.2 l)^2 = 1.44 l^2$

Increase in the area of the square =  $1.44 l^2 - l^2 = 0.44 l^2$

Percentage increase in the area =  $(0.44 l^2)/l^2 \times 100 = 44\%$

$\therefore$  The % increase in the area is 44%



**Que. 27** Three positions of a dice are given below. What will come opposite to the face containing 'Black'?

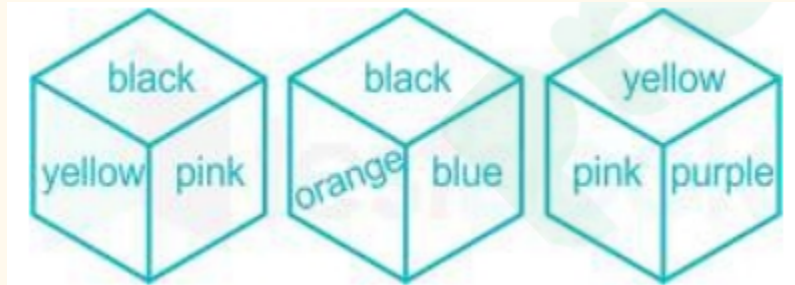

1. Yellow
2. Pink
3. Blue
4. Purple

**Ans.** Correct Option - 4

The given position of dice are:

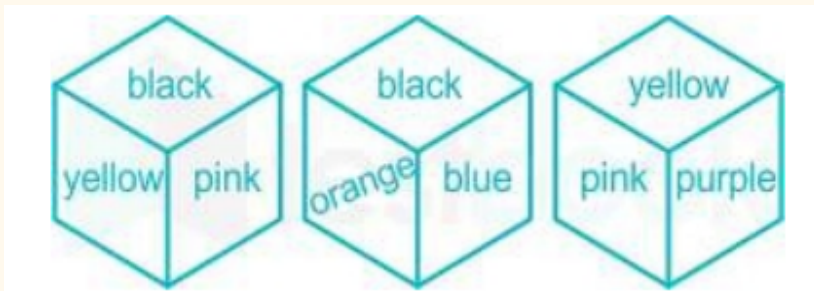

It is clear that the adjacent phase of black is yellow and pink from the first position of dice. And also from second position of dice it is clear that black phase is also adjacent to orange and blue. So, from third position of the dice it is clear that the purple is opposite to the black. Hence, 'Purple' is the correct answer.

**Que. 28**

**Koodankulam is famous for:**

1. Nuclear power plant
2. Thermal power plant
3. Biosphere reserve
4. Major port in tamil Nadu

**Ans.** Correct Option - 1

The correct answer is Nuclear power plant.

Nuclear power plants are a type of power plant that uses the process of nuclear fission to generate electricity.

Kudankulam Nuclear Power Plant is the largest nuclear power station in India, situated in Koodankulam in the Tirunelveli district of Tamil Nadu.

Kudankulam Nuclear Power Plant is being developed by the Nuclear Power Corporation of India (NPCIL) in collaboration with Atomstroyexport, the Russian state company. The current installed capacity is 2GW.

**Que. 29**

**80% of CP = 60% of SP. Find the profit or loss %**

**1. 33.33% profit**

**2. 25% loss**

**3. 30% profit**

**4. 10% loss**

**Ans.** Given: Correct Option - 1

80% of CP = 60% of SP

Concept used:

Profit and loss

Calculation:

$$\Rightarrow (80/100) \times CP = (60/100) \times SP$$

$$\Rightarrow 80 \times CP = 60 \times SP$$

$$\Rightarrow CP : SP = 60 : 80$$

$$\Rightarrow CP : SP = 3 : 4$$

$$\text{Profit} = SP - CP$$

$$\text{Profit} = 4 - 3$$

$$\text{Profit} = 1 \text{ unit.}$$

$$\text{Profit \%} = (1/3) \times 100$$

$$\Rightarrow 33.33\%$$

$\therefore$  The profit% is 33.33%

**Que. 30** Consider the given argument and decide which of the given assumptions is (are) implicit.

**Argument:**

Y advised X that if he/she wants to study Management, he/she should join IIM

**Assumptions:**

**1. IIM provides good Management education**

**2. X listens to the advice given by Y.**

1. Neither 1 nor 2 is implicit.
2. Only assumption 2 is implicit.
3. Only assumption 1 is implicit.
4. Both 1 and 2 are implicit.

**Ans.** Correct Option - 4

It can be assumed that IIM does provide good management studies that is why Y advised X. Hence assumption 1 supports the argument.

If Y is advising X therefore, it can be assumed that X would be listening to Y. So, assumption 2 supports the argument.

Note:

When you are advising someone, you can assume that the person is willing to listen to your advice. That is, the possibility of such an assumption does exist.

Thus, in this question, the second assumption is implicit. When Y is advising X, he might be assuming that X will follow his advice.

**Que. 31**

**Which state is not a part of the 'Seven Sisters' of North East?**

1. Meghalaya
2. Sikkim
3. Arunachal Pradesh
4. Tripura

**Ans.** Correct Option - 2

The correct answer is Sikkim.

The seven sisters states of India from north to south are Arunachal Pradesh, Assam, Meghalaya, Nagaland, Manipur, Tripura, and Mizoram.

Sikkim belongs to the group of northeastern states but doesn't belong to Seven Sisters State.

Sikkim also called the only brother of seven sisters states.

The total area of seven sisters state is 2,55,511 sq km.

It is 7% of the total area of India's area.

**Que. 32 A student got 20% marks and failed by 72 marks. If he scores 40% marks then he gets 8 marks more than the passing marks. Find the passing marks.**

1. 150
2. 152
3. 142

#### 4. 160

**Ans.** Given: Correct Option - 2

A student got 20% marks and failed by 72 marks. If he scores 40% marks then he gets 8 marks more than the passing marks.

Concept used:

Percentage.

Calculation:

Let total marks be  $100x$

A student scores 20% marks and failed by 72 marks means if he gets 72 marks he would pass  
 $\Rightarrow 20x + 72$

A student scores 40% marks and gets 8 marks more than passing marks.

$\Rightarrow 40x - 8$

Passing marks

$\Rightarrow 20x + 72 = 40x - 8$

$\Rightarrow 20x = 80$

$\Rightarrow x = 4$

Passing marks =  $20x + 72$

=  $80 + 72$

= 152

$\therefore$  The passing marks is 152

**Que. 33 Which assumptions are implied from the below statement?**

**Statement:**

**Tanmay is a national level chess player.**

**Assumptions:**

**I: Tanmay has played with Viswanathan Anand.**

**II: Tanmay has defeated many players in chess.**

**1. Only I is implicit.**

**2. Only II is implicit.**

**3. Both I and II are implicit.**

**4. Neither I nor II is implicit.**

**Ans.** Correct Option - 2

From the information above we cannot assume the players with which Tanmay has played chess.

Therefore, assumption I is not implicit.

However, the information available in the statement above is sufficient to assume that Tanmay might have defeated many players in chess as he qualified for the nationals.

Therefore, assumption II is implicit.

Hence, Only II is implicit.

**Que. 34**

**In which of the following Himalayan ranges is the Banihal Pass situated? 1.**

**Great Himalayas**

**2. Pir Panjal**

**3. Ladakh**

**4. Zaskar**

**Ans.** Correct Option - 2

The Banihal Pass is situated in Pir Panjal Himalayan Range.

The Pir Panjal Range is a range of Inner Himalayan mountains stretching from east-southeast (ESE) to west-northwest (WNW) through Himachal Pradesh, Indian state, and Jammu and Kashmir, Indian Union Territory.

Pir Panjal is the greatest range of the Lesser Himalayas.

The Pir Panjal Railway Tunnel, a rail tunnel of 11,215 meters, passes through Jammu and Kashmir's Pir Panjal Range.

The tunnel was opened to regular service on 26 June 2013.

It is the longest railway tunnel in India and the fourth-longest tunnel in Asia.

**Que. 35**

**Find the smallest number divisible by 15, 28 and 25 which gives remainder as 8 in each case.**

**1.**

**2100**

**2. 2092**

**3. 2108**

**4. 2180**

**Ans.** Given: Correct Option - 3

Numbers = 15, 28 and 25

Remainder = 8

Calculations:

LCM of 15, 28 and 25 = 2100

Number which will give 8 as remainder = 2100 + 8

⇒ 2108

∴ The smallest number divisible by 15, 28 and 25 which gives remainder as 8 in each case is 2108.

**Que. 36** In the question below is given a statement followed by two courses of action numbered I and II. You have to assume everything in the statement to be true and on the basis of the information given in the statement, decide which of the suggested course of action logically follow(s) for pursuing. **Statement: Bullying can impact a student on physical, mental and emotional levels. Courses of Action:**

**I: The child should ignore the instances of bullying.**

**II: The schools should set clear and enforceable rules against the practice of bullying.**

- 1. Only I follows**
- 2. Only II follows**
- 3. Neither I nor II follows**
- 4. Both I and II follow**

**Ans.** Correct Option - 2

From the statement above, we understand the effects of bullying on a student. But the course of action mentioned in I is not viable as it will continue the practice of bullying.

Therefore, I does not follow.

On the other hand, setting clear and enforceable rules against the practice of bullying will be a feasible course of action as it will reduce the number of bullying cases.

Therefore, II follows.

Hence, Only II follows.

**Que. 37**

**The President of India has the power of pardoning under .**

- 1. Article 72**
- 2. Article 73**
- 3. Article 74**
- 4. Article 76**

**Ans.** Correct Option - 1

The correct answer is Article 72.

Article 72 of the Indian Constitution gives the President the power of pardoning.

Pardon: means completely absolving the person of the crime and letting him go free.

Under Article 72, the President of India can grant a pardon or reduce the sentence of a convicted person, particularly in cases involving capital punishment.

There are five different types of pardoning which are mandated by law: Pardon, Commutation, Reprieve, Respite and Remission.

**Que. 38**

There are three numbers a, b and c; such that:  $a : b : c = 2 : 3 : 1$ . The sum of a, b and c is 120. Find b.

- 1.
- 20
2. 60
3. 30
4. 45

**Ans.** Correct Option - 2

$\therefore$  The given relation between a, b and c is

$$a : b : c = 2 : 3 : 1$$

Let the numbers be  $a = 2x$ ,  $b = 3x$ , and  $c = x$

Now, the sum of the numbers is 120

$$\text{So, } a + b + c = 120$$

$$\Rightarrow 2x + 3x + x = 120$$

$$\Rightarrow 6x = 120 \text{ So,}$$

$$b = 3x = 60$$

$\therefore$  The required number b is 60

**Que. 39** In the given figure Triangle represents Tennis Players, Rectangle represents Football Players, Circle represents Cricket Players. Which of the following set of letters represent those who play both cricket as well as football?

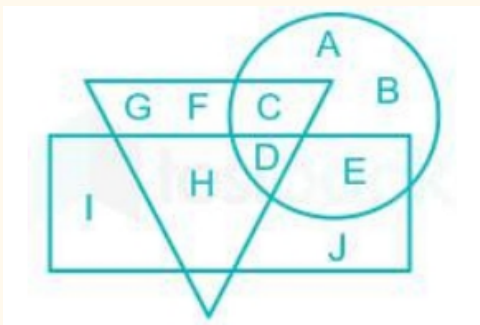

1. DE
2. EJ
3. CD
4. BE

**Ans.** Correct Option - 1

The set of letters representing both who plays cricket and football is represented in the intersection area of Cricketers and Football players.

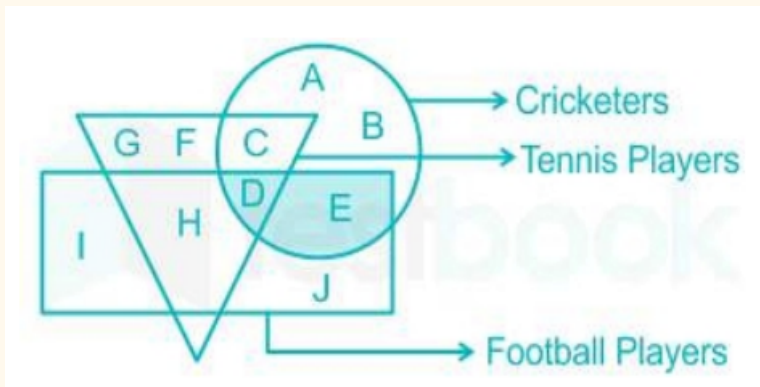

Hence, DE is the correct answer.

**Que. 40**

**Who was the founder of Prathana Samaj?**

1. Dr. Atmaram Pandurang
2. Dayanand Saraswati
3. Keshab Chandra sen
4. Swami Vivekanand

**Ans.** Correct Option - 1

Dr. Atmaram Pandurang was the founder of Prathana Samaj.

Dr. Atmaram Pandurang has founded Prathana Samaj in the year 1867 in western India for religious and social reforms.

The main aim of the Prathana Samaj was to make people believe in one God and worship only one God. The emphasis was on monotheism but on the whole, the samaj was more concerned with social reform than with the religion.

The Prathana Samaj was very attached to the Bhakti cult of Maharashtra.

**Que. 41** Difference between compound interest and simple interest is Rs. 3375 in 2 years and the rate of interest is 15%. Find the principal amount.

1. Rs. 100,000
2. Rs. 150,000
3. Rs. 160,000
4. Rs. 200,000

**Ans.** Given:

Correct Option - 2

Rate = 15 %

Difference between CI and SI in 2 years = Rs. 3375

Time = 2 years



Concept:

$$CI - SI = P \times (R/100)^2$$

Calculation:

$$\Rightarrow 3375 = P \times (15/100)^2$$

$$\Rightarrow P = 150000$$

∴ The required result will be 150,000

**Que. 42** Count the number of blocks in the following figure.



1. 32
2. 34
3. 36
4. 38

**Ans.** Correct Option - 3

There are three layers as we can see in the following figure:

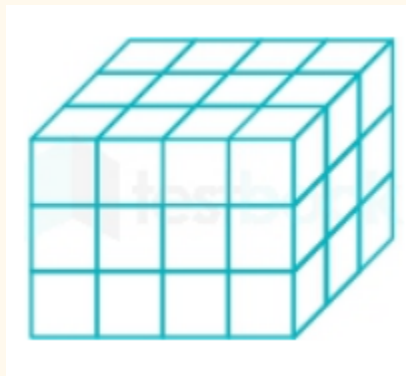

In the given cube, there are 3 layers,

As we can see, in the first layer, there are 4 X 3 blocks

Hence, in the front layer, there are 12 blocks.

Similarly, in the middle layer there are 12 blocks.

And in back/last layer there are 12 blocks.

So total number of blocks will be = 12 + 12 + 12 = 36 cubes

As it is a symmetrical figure the blocks after the 1st layer have to be counted.  
Hence, correct answer will be 36

**Que. 43**

**On which on the following dates was ISRO found?**

1. 12th August, 1954
2. 15th August, 1969
3. 13th August, 1992
4. 11th August, 1990

**Ans.** Correct Option - 2

The correct answer is 15th August, 1969.

Indian Space Research Organisation was formed on 15th August 1969.

It superseded the erstwhile INCOSPAR. Vikram Sarabhai, having identified the role and importance of space technology in a Nation's development, provided ISRO the necessary direction to function as an agent of development.

**Que. 44 A fruit seller gave two successive discounts of 10% and 20% to the buyer. Find the net discount given to the buyer.**

1. 30%
2. 32%
3. 28%
4. 25%

**Ans.** Given- Correct Option - 3

Two successive discounts = 10% and 20%

Concept Used -

Discounted Value = Actual Value(1 - Discount%)

Calculation-

Let the MP be 100

After 1st discount of 10% price becomes 100 - 10

⇒ 90

After 2nd discount of 20% price becomes 90 - 18

⇒ 72

∴ The net discount offered to the buyer is 100 - 72

⇒ 28%

Que. 45 Find out the number of circles in the given figure.

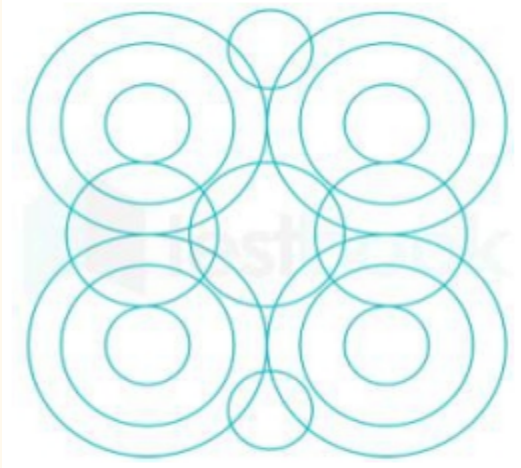

- 1. 14
- 2. 16
- 3. 17
- 4. 18

Ans. Correct Option - 3

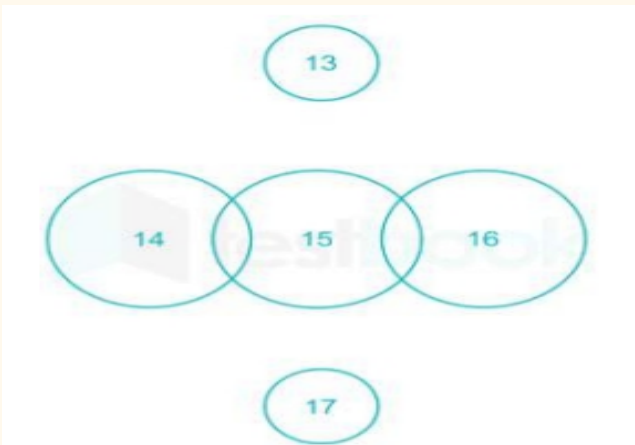
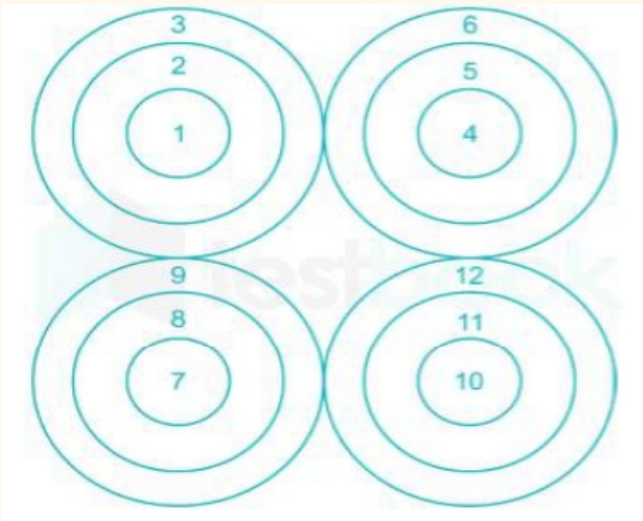

Hence total 17 circles are there.

**Que. 46**

**At which of the following places is the International Court of Justice situated?**

1. Rome
2. Vienna
3. The Hague
4. Geneva

**Ans.** Correct Option - 3

The International Court of Justice is the UN's principal judicial organ which was established in June 1945. The seat of the court is situated at the Peace Palace in The Hague, Netherlands.

**Que. 47**

**Find the value of  $5 \sin 15^\circ \sec 75^\circ + 2 \tan 45^\circ + 3 \sec^2 30^\circ$ .**

1. 9
2. 10
3. 11
4. 12

**Ans.** Given: Correct Option - 3

$$5 \sin 15^\circ \sec 75^\circ + 2 \tan 45^\circ + 3 \sec^2 30^\circ$$

Calculation:

$$5 \sin 15^\circ \sec 75^\circ + 2 \tan 45^\circ + 3 \sec^2 30^\circ$$

$$\Rightarrow 5 \sin 15^\circ \sec(90^\circ - 15^\circ) + 2 \tan 45^\circ + 3 \sec^2 30^\circ$$

$$\Rightarrow 5 \sin 15^\circ \operatorname{cosec} 15^\circ + 2 \tan 45^\circ + 3 \sec^2 30^\circ$$

$$\Rightarrow 5 \sin 15^\circ (1/\sin 15^\circ) + 2 \times 1 + 3 (2/\sqrt{3})^2$$

$$\Rightarrow 5 + 2 + 4$$

$$\Rightarrow 11$$

$\therefore$  The value of  $5 \sin 15^\circ \sec 75^\circ + 2 \tan 45^\circ + 3 \sec^2 30^\circ$  is 11.

Que. 48 Which answer figure will complete the pattern in the following question figure?

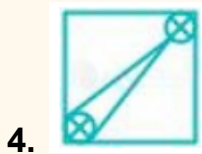
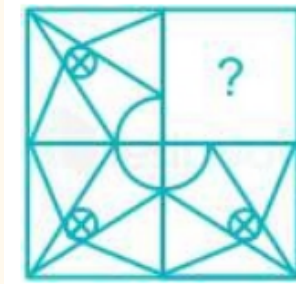

Ans. Correct Option - 1

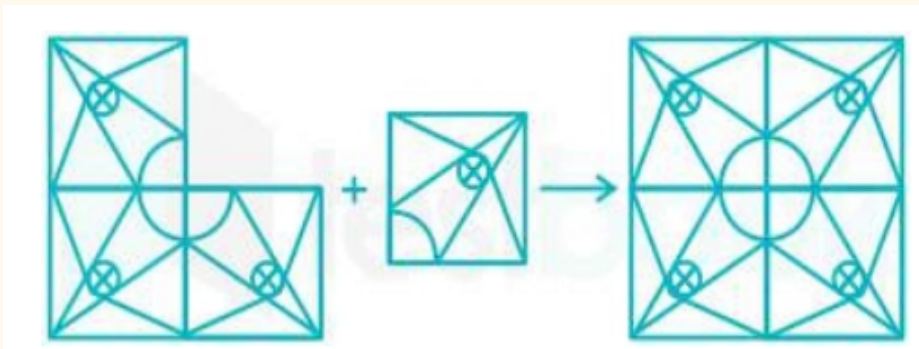

Hence, the figure in option 1) will complete the pattern.

Que. 49

In which year the Environment Protection Act was passed?

1. 1982

2. 1986

**3. 1992**

**4. 1996**

**Ans.** Correct Option - 2

The environment protection act was passed by the parliament of India in 1986.

Under Article 253 of the constitution.

It came into force on 19 November 1986.

The purpose of this act was to implement the decisions of the UN conference on the Human Environment.

**Que. 50**

**What will be the HCF of 56, 216, 28 ?**

**1. 28**

**2. 2**

**3. 8**

**4. 4**

**Ans.** Given- Correct Option - 4

Given numbers = 56, 216, 28

Concept Used-

The greatest number which divides a given set of numbers is called the HCF of that given set of numbers.

Calculation-

$$56 = 7 \times 2^3$$

$$216 = 2^3 \times 3^3$$

$$28 = 2^2 \times 7$$

$$\therefore \text{HCF of } 56, 216, 28 = 2^2 = 4$$

**Que. 51** If '+' stands for 'division'; '×' stands for 'addition'; '-' stands for 'multiplication'; '÷' stands for 'subtraction', which of the following equations is correct?

**1.  $5 - 3 + 2 \times 4 \div 8 = 2$**

**2.  $5 \times 3 + 2 - 4 \times 8 = 19$**

**3.  $5 \div 3 \times 2 - 4 + 8 = 8$**

**4.  $5 + 3 \times 2 \div 4 - 8 = 4$**

**Ans.** Correct Option - 2

Changing operators as given instruction:-

Let's check each option,

$$1) 5 - 3 + 2 \times 4 \div 8 = 2$$

changing signs as per the table, equation will become:-  $5 \times 3 \div 2 + 4 - 8 = 2$

$$= 5 \times 1.5 + 4 - 8$$

$$= 7.5 + 4 - 8$$

$$= 11.5 - 8$$

$$= 3.5 \neq 2$$

$$2) 5 \times 3 + 2 - 4 \times 8 = 19$$

changing signs as per the table, equation will become:-  $5 + 3 \div 2 \times 4 + 8 = 19$

$$= 5 + 1.5 \times 4 + 8$$

$$= 5 + 6 + 8$$

$$= 19 = 19$$

$$3) 5 \div 3 \times 2 - 4 + 8 = 8$$

changing signs as per the table, equation will become:-  $5 - 3 + 2 \times 4 \div 8 = 8$

$$= 5 - 3 + 2 \times 0.5$$

$$= 5 - 3 + 1$$

$$= 6 - 3$$

$$= 3 \neq 8$$

$$4) 5 + 3 \times 2 \div 4 - 8 = 4$$

changing signs as per the table, equation will become:-  $5 \div 3 + 2 - 4 \times 8 = 4$

$$= 1.67 + 2 - 32$$

$$= 3.67 - 32$$

$$= -28.33 \neq 4$$

Hence, option 2 is giving us the correct equation after changing signs.

### Que. 52

Which among the following is a scheme that is aimed at the development of girl child in the country?1.

**Vidya Lakshmi Scheme**

**2. Pradhan Mantri Shishu Vikas Yojana**

**3. Pradhan Mantri Sukanya Samriddhi Yojana**

**4. Pradhan Mantri Valika Suraksha Yojana**

**Ans.** Correct Option - 3

Pradhan Mantri Sukanya Samriddhi Scheme is aimed at the security of girl child in the country. It was launched on 22 January 2015.

The parents of the girl child can open the account before she attains the age of 10 years and deposit money till the child becomes 14 years old.

After the age of 21 years, the amount can be withdrawn by the girl child.

**Que. 53**

**Find the number of zeroes in  $10 \times 20 \times 30 \times \dots \times 1000$ .**

- 1. 100**
- 2. 124**
- 3. 120**
- 4. 150**

**Ans.** Given: Correct Option - 2

$$10 \times 20 \times 30 \times \dots \times 1000$$

Concept used:

Take 10 as common from each term.

Number of trailing zeroes in  $n!$  = Divide  $n$  by 5 and add all the quotients till it reaches less than 5.

Calculations:

$$10 \times 20 \times 30 \times \dots \times 1000$$

$$\Rightarrow (10 \times 1) \times (10 \times 2) \times (10 \times 3) \times (10 \times 4) \dots \times (10 \times 100)$$

$$\Rightarrow 10^{100} \times (1 \times 2 \times 3 \times \dots \times 100)$$

$$\Rightarrow 10^{100} \times (100!)$$

$$\text{Number of zeroes} = 100 + \{(100)/5 + (20)/5\}$$

$$\Rightarrow 100 + 20 + 4$$

$$\Rightarrow 124$$

$\therefore$  The number of trailing zeroes in  $10 \times 20 \times 30 \times \dots \times 1000$  is 124.

**Que. 54 Which of the following interchanges of signs would make the given equation correct?**

$$5 + 6 \div 3 - 12 \times 2 = 17$$

- 1.  $\div$  and  $\times$**
- 2.  $+$  and  $\times$**
- 3.  $+$  and  $\div$**
- 4.  $+$  and  $-$**

**Ans.** Correct Option - 1 Given

equation:  $5 + 6 \div 3 - 12 \times 2 = 17$  Let's

check each option,

1) Interchanging  $\div$  and  $\times$

$$\text{Equation will become } 5 + 6 \times 3 - 12 \div 2$$

$$= 5 + 6 \times 3 - 6$$

$$= 5 + 18 - 6$$

$$= 23 - 6$$

$$= 17 = 17$$



2) Interchanging + and  $\times$

$$\begin{aligned} \text{Equation will become } & 5 \times 6 \div 3 - 12 + 2 \\ & = 5 \times 2 - 12 + 2 \\ & = 10 - 12 + 2 \\ & = 12 - 12 \\ & = 0 \neq 17 \end{aligned}$$

3) Interchanging + and  $\div$

$$\begin{aligned} \text{Equation will become } & 5 \div 6 + 3 - 12 \times 2 \\ & = 0.833 + 3 - 12 \times 2 \\ & = 0.833 + 3 - 24 \\ & = 3.833 - 24 \\ & = -20.167 \neq 17 \end{aligned}$$

4) Interchanging + and -

$$\begin{aligned} \text{Equation will become } & 5 - 6 \div 3 + 12 \times 2 \\ & = 5 - 2 + 12 \times 2 \\ & = 5 - 2 + 24 \\ & = 29 - 2 \\ & = 27 \neq 17 \end{aligned}$$

Hence, option 1 is the correct answer.

**Que. 55**

**In which among the following areas the Sabrimala Temple is located?**

- 1. Periyar Tiger Reserve**
- 2. Kanha National Park**
- 3. Anamalai Tiger reserve**
- 4. None of the Above**

**Ans.** Correct Option - 1

Sabrimala Temple is located inside the Peiyar Tiger Reserve.

It is located in Pathanamthitta Distt. of Kerala.

The temple is dedicated to Lord Ayyappan who is a celibate.

Lord Ayyappan is also known as Darma Sastha.

It is believed that Lord Ayyappan is the Son of Lord Shiva and Mohini (The Female Incarnation of Lord Vishnu).

Kanha National park is located in Madhya Pradesh.

Anamalai Tiger Reserve is located in Tamil nadu

**Que. 56** Bhushan buys an article at Rs. 1500 and sell it to Amit at Rs. 2000, find the profit percentage of Bhushan?

1. 33.33%
2. 25%
3. 50%
4. 40%

**Ans.** Correct Option - 1 Given:

CP = Rs. 1500

SP = Rs. 2000

Concept:

Profit percentage =  $[(SP - CP)/CP] \times 100$

Calculation:

Profit% =  $(SP - CP)/CP \times 100$

=  $[(2000 - 1500)/1500] \times 100$

=  $(500/1500) \times 100$

= 33.33%

∴ The profit percentage of Bhushan is 33.33%.

**Que. 57** In a certain code language, "TAP" is written as "39" and "LAP" is written as "31". How is "MAT" written in that code language?

1. 36
2. 38
3. 42
4. 30

**Ans.** Correct Option - 1

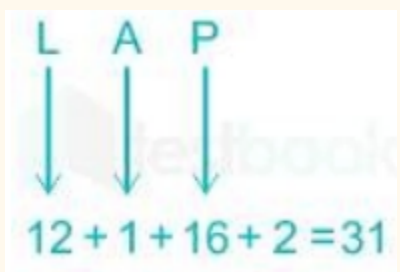

Similarly,



M A T  
↓ ↓ ↓  
13 + 1 + 20 + 2 = 36

Hence, '36' is the correct answer.

**Que. 58**

**Who among the following was the first Tirthankara of Jainism?**

1. Rishabhanatha
2. Mahavira
3. Bahubali
4. Mallinatha

**Ans.** Correct Option - 1

Lord Rishabhanatha, also known as Rishabdeva was the first Tirthankar of Jainism.

Bahubali was the son of Lord Rishabdeva.

Mahavira was the 24th Tirthankara of Jainism.

Mallinatha is believed to be a woman of shwetamber sect while Digambara sect believes that all the Tirthankaras were males.

**Que. 59** The adjacent angles of the rhombus are in the ratio of 4 : 5. Find the difference between the larger and smaller angle.

1.  $10^\circ$
2.  $20^\circ$
3.  $15^\circ$
4.  $25^\circ$

**Ans.** Given : Correct Option - 2

The ratio of the adjacent angle of the rhombus = 4 : 5

Concept used :

The sum of the adjacent angles of the rhombus is  $180^\circ$

Calculation :

Let the smaller and larger angle be  $4x$  and  $5x$  respectively.

$$\Rightarrow 4x + 5x = 180^\circ$$

$$\Rightarrow 9x = 180^\circ$$

$$\Rightarrow x = 20^\circ$$

Difference between the larger and smaller angle =  $5x - 4x$

$$= x = 20^\circ$$

$\therefore$  The difference between the larger and smaller angle is  $20^\circ$ .

**Que. 60** In a row Sindhu is 15<sup>th</sup> from front end and Madhu is 10<sup>th</sup> from back end. If they interchange their positions there are 5 persons between Sindhu and Madhu.

**Total number of persons in the row?**

1. 28
2. 29
3. 30
4. 31

**Ans.** Correct Option - 3

Sindhu is 15<sup>th</sup> from front end and Madhu is 10<sup>th</sup> from back end.

On combining the statements, we get,

(Front end is taken on the top and back end is taken on the bottom)

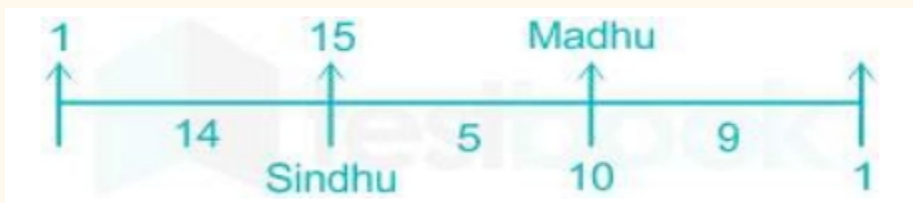

Total number of persons in the queue are  $14 + 5 + 9 + 2 = 30$

Therefore, 30 is the correct answer.

**Que. 61**

**Which of the following is the current Chief Minister of Himachal Pradesh?**

1. Jai Ram Thakur
2. Raj Singh Tomar
3. Sanchit Kumar Manoranjan
4. Jeetaram Majhi

**Ans.** Correct Option - 1

The correct answer is Jai Ram Thakur.

Jai Ram Thakur has been sworn in as the 14th Chief Minister of Himachal Pradesh along with 11 other ministers at a ceremony in Shimla.

**Que. 62** The sum of two numbers is 60 whereas HCF and LCM of the numbers are 12 and 72 respectively. Find the sum of reciprocal of these numbers.

1.  $\frac{5}{6}$
2.  $\frac{5}{72}$
3.  $\frac{6}{5}$
4.  $\frac{72}{5}$

**Ans.** Given: Correct Option - 2

Sum of two numbers = 60

HCF of the given numbers = 12

LCM of the given numbers = 72

Calculations:

Let the two numbers be  $12x$  and  $12y$ .

According to questions,

$$12x + 12y = 60$$

$$\Rightarrow x + y = 5 \text{-----(1)}$$

$$\text{LCM} = 12 \cdot xy = 72$$

$$\Rightarrow xy = 6 \text{-----(2)}$$

From (1) and (2),

$$\Rightarrow x = 3, y = 2$$

$$\left(\frac{1}{12x}\right) + \left(\frac{1}{12y}\right)$$

$$\Rightarrow \left(\frac{1}{36}\right) + \left(\frac{1}{24}\right)$$

$$\Rightarrow \frac{5}{72}$$

$\therefore$  The sum of reciprocal of the given numbers is  $\frac{5}{72}$ .

**Que. 63** Read the given statements and conclusions carefully. Assuming that the information given in the statements is true, even if it appears to be at variance with commonly known facts, decide which of the given conclusions logically follow(s) from the statements.

**Statements:**

1. Some bananas are mangoes.
2. Some mangoes are cats.

**Conclusions:**

- I. All cats are bananas.
  - II. Some cats are mangoes.
1. Neither conclusion I nor II follows.
  2. Both conclusions I and II follow.
  3. Only conclusion II follows.
  4. Only conclusion I follows.

**Ans.** Correct Option - 3

The least possible Venn diagram for the given statement is :



- I. All cats are bananas → False (It is possible but not definite)
  - II. Some cats are mangoes → True ( Some mangoes are cats)
- Hence, only conclusion II follows.

**Que. 64 BCCI has announced the schedule for IPL 2020 to be held in UAE. The season kickstartedinwhichofthe following cities?**

- 1. Abu Dhabi
- 2. Dubai
- 3. Sharjah
- 4. Al Ain

**Ans.** Correct Option - 1

The correct answer is Abu Dhabi.

BCCI has announced the schedule for IPL 2020 to be held in UAE.

The season will kickstart on 19 September 2020 in Abu Dhabi with a clash between defending champions Mumbai Indians and Chennai Super Kings.

Dubai will host the second game where Delhi Capitals will face Kings XI Punjab on September 20.

Dubai will host 24 games, 20 matches will be played in Abu Dhabi while the remaining 12 in Sharjah.

**Que. 65 Find "?" in the given expression**

$$12\% \text{ of } 1200 + ? = 18\% \text{ of } 5400$$

- 1. 654
- 2. 676
- 3. 828
- 4. 538

**Ans.** Correct Option - 3

Calculation:

Our given equation is  $12\% \text{ of } 1200 + ? = 18\% \text{ of } 5400$

$$\Rightarrow 12/100 \times 1200 + ? = 18/100 \times 5400$$

$$\Rightarrow 12 \times 12 + ? = 18 \times 54$$

$$\Rightarrow 144 + ? = 972$$

$$\Rightarrow ? = 972 - 144$$

$$\Rightarrow ? = 828$$

$\therefore$  The value of the given expression is 828.

**Que. 66 Select the related word from the given alternatives.**

**Brain : Neurology :: ? : Cardiology**

1. Liver
2. Ears
3. Heart
4. Eyes

**Ans.** Correct Option - 3

The above relationship is about the part : term related to it.

Neurology is related to brain.

Similarly,

Cardiology is related with Heart.

Hence, Heart is the correct answer.

**Que. 67 How many languages have been mentioned in the Eighth Schedule of the Indian Constitution?**

1. 28
2. 24
3. 18
4. 22

**Ans.** Correct Option - 4

The correct answer is 22.

22 languages have been mentioned in the Eighth Schedule of the Indian Constitution. These languages are- Assamese, Bengali, Bodo, Dogri, Gujarati, Hindi, Kannada, Kashmiri, Konkani, Maithili, Malayalam, Manipuri, Marathi, Nepali, Odia, Punjabi, Sanskrit, Santali, Sindhi, Tamil, Telugu, and Urdu.

**Que. 68** A metallic solid cuboid of sides 44 cm, 32 cm and 36 cm melted and converted into some number of spheres of radius 12 cm. How many such sphere can be made with the metal ( $\pi = 22/7$ )?

1. 5
2. 6
3. 7
4. 8

**Ans.** Given: Correct Option - 3

The sides of the cuboid are 44 cm, 32 cm, and 36 cm

The radius of the sphere is 12 cm

Concept Used:

The volume of a cuboid of sides l, b and h =  $l \times b \times h$

The volume of the sphere of radius r =  $(4/3)\pi r^3$

Calculation:

The volume of the metallic cuboid is  $(44 \times 32 \times 36)$  cm<sup>3</sup>

The volume of the sphere is  $(4/3) \times \pi \times 12^3$

Let, the total number of such sphere is n

Accordingly,

$$44 \times 32 \times 36 = n \times (4/3) \times \pi \times 12^3$$

$$\Rightarrow 44 \times 32 \times 36 = n \times (4/3) \times (22/7) \times 12 \times 12 \times 12$$

$$\Rightarrow n = 44 \times 32 \times 36 \times (3/4) \times (7/22) \times (1/12) \times (1/12) \times (1/12)$$

$$\Rightarrow n = 7$$

$\therefore$  Such 7 spheres can be made by given metallic cuboid.

**Que. 68** Mohan is standing facing East. He turns  $90^\circ$  in an anticlockwise direction. He then turns  $45^\circ$  in the clockwise direction. Which direction is he facing now?

1. South-West
2. North-West
3. North-East
4. South-East

**Ans.**

Correct Option - 3

Given:

Mohan is standing facing East.

He turns  $90^\circ$  in the anticlockwise direction.

Mohan now turns toward the North direction.



Then he turns  $45^\circ$  in the clockwise direction.  
Now he is facing North-East.  
Hence, Mohan is facing North-East direction.

**Que. 70 The first complete census in India was held in the year .**

1. 1873
2. 1891
3. 1881
4. 1885

**Ans.** Correct Option - 3

The correct answer is option 3, i.e. 1881.

Census was conducted non-synchronously between 1865 and 1872 in different parts of the country. This effort culminating in 1872 has been popularly labeled as the first Census of India.

However, the first synchronous Census in India was carried out in 1881. An unbroken chain of censuses since then gives the Indian Census a unique historical legacy unparalleled in the world. Census 2011 is the 15th Census in this continuous series from 1872 and the 7th since Independence.

**Que. 71 In  $\Delta ABC$ , O is the circumcentre of the triangle and  $\angle BOC = 60^\circ$ , then what will be the value of  $\angle BAC$ ?**

1.  $90^\circ$
2.  $30^\circ$
3.  $60^\circ$
4.  $45^\circ$

**Ans.** Correct Option - 2 Given:

O is circumcentre

$\angle BOC = 60^\circ$

Formula used:

The angle subtended at the center is double the angle subtended at the circle

Calculation:

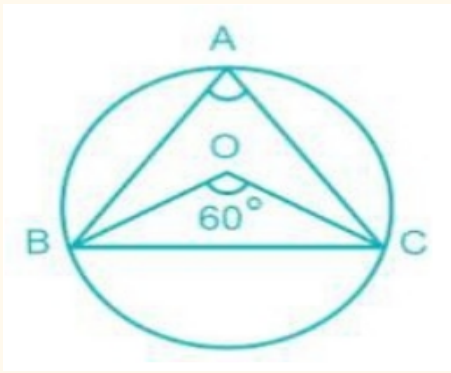

$$\angle BOC = 2 \times \angle BAC$$

$$\Rightarrow 60^\circ = 2 \times \angle BAC$$

$$\Rightarrow \angle BAC = 30^\circ$$

$$\therefore \angle BAC \text{ is } 30^\circ$$

**Que. 72 Direction:** In the given question a statement is followed by two conclusions numbered I and II. You have to assume everything in the statement to be true, then consider the two conclusions together and decide which of them logically follows beyond a reasonable doubt from the information given in the statement. **Statement:**

**All roses are red**

**All red are color**

**Few red are yellow**

**Conclusion:**

**I. Some roses are color**

**II. Some color are yellow**

**1. Both Conclusions follow**

**2. Only Conclusion II follows**

**3. Neither Conclusion I nor Conclusion II follows**

**4. Only Conclusion I follows**

**Ans.**

Correct Option - 1

Statement:

All roses are red

All red are color

Few red are yellow

The possible Venn diagram of the given statement are:

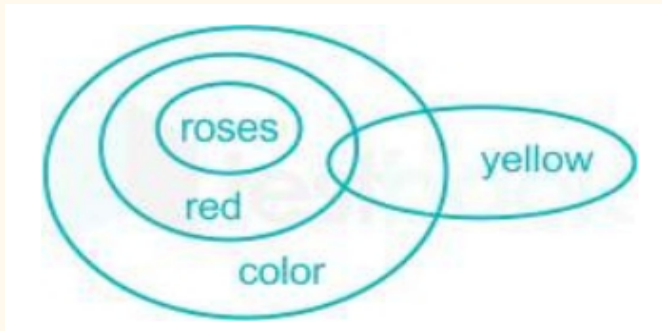

Conclusion:

- I. Some roses are color. (True, as all roses are red and all red are color.)
- II. Some color are yellow. (True, as few red are yellow and all red are color.)

**Que. 73 Which among the following Acts was also known as the Black Act?**

1. Rowlatt Act
2. Pitt's Act
3. Indian Councils Act
4. Vernacular Press Act

**Ans.** Correct Option - 1

Rowlatt Act was also known as the Black Act.

It is the anarchical and revolutionary crimes act.

It was introduced by the British Government in 1919.

It was named after its president, British judge Sir Sidney Rowlatt.

**Que. 74 A Ans. of 100L contains 75 percent water and rest liquid sugar. How much liquid sugar must be added to make 50 percent sugar Ans.?**

1. 30 L
2. 20 L
3. 25 L
4. 50 L

**Ans.** Given: Correct Option - 4

Amount of sugar and water in the Ans. = 25% and 75%

The total amount of Ans. = 100 L

New percentage of sugar in the mixture = 50%

Calculation:

Amount of sugar in the initial Ans. =  $25\% \times 100 \text{ L} = 25 \text{ L}$

Amount of water in the initial Ans. =  $75\% \times 100 \text{ L} = 75 \text{ L}$

Let x litre of sugar Ans. is added.

Hence,

$$(25 + x)/(100 + x) \times 100 = 50$$

(42)

$$\Rightarrow (25 + x)/(100 + x) = 1/2$$

$$\Rightarrow 50 + 2x = 100 + x$$

$$\Rightarrow x = 50 \text{ lt}$$

∴ The amount of sugar added into the mixture to get a 50% sugar Ans. is 50 L liquid sugar.

**Que. 75** Select the option that will correctly fit in the blank space in the given figure series.

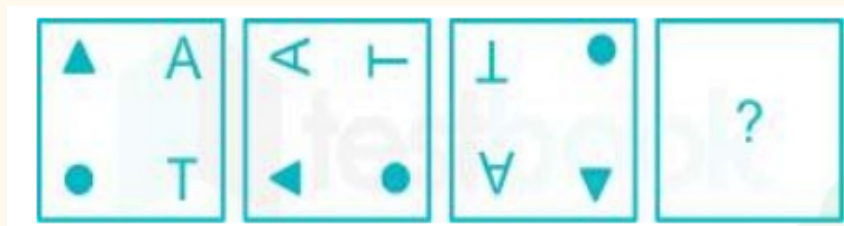

**Ans.** Correct Option - 4

The pattern followed here is:

The elements inside the box is moving 90° anticlockwise in each step.

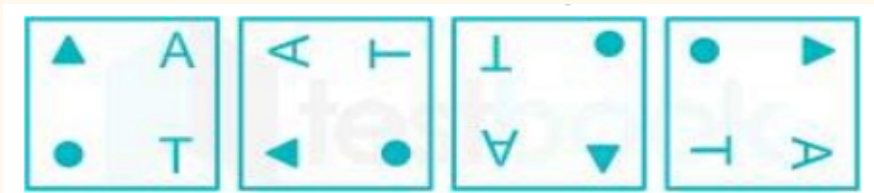

There is only one image that satisfies the rotation in the correct manner.  
Hence, option 4 is the correct answer.

**Que. 76 What is pH of Lemon Juice?**

1. 3.8
2. 5.5
3. 6.6
4. 2.5

**Ans.** Correct Option - 4

pH of some common aqueous Ans.s

Ans.	pH
1M HCl	0.0
Gastric juice	1.0
Lemon juice	2-3
Vinegar	3.0
Tomato juice	4.1
Pure water, sugar	7.0

**Que. 77 If the angles of triangle ABC are  $2x^\circ$ ,  $(3x - 12)^\circ$ , and  $(5x - 18)^\circ$ , then find the largest angle?**

1.  $98^\circ$
2.  $87^\circ$
3.  $80^\circ$
4.  $107^\circ$

**Ans.** Given: Correct Option - 2

$2x^\circ$ ,  $(3x - 12)^\circ$ , and  $(5x - 18)^\circ$  are angles of  $\Delta ABC$ .

Concept used:

Sum of angles of triangle are  $180^\circ$ .

Calculation:

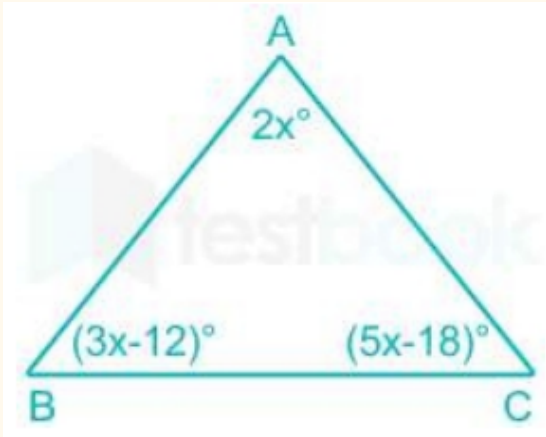

In  $\Delta ABC$ ,

$$\angle A + \angle B + \angle C = 180^\circ$$

$$\Rightarrow 2x^\circ + (3x - 12)^\circ + (5x - 18)^\circ = 180^\circ$$

$$\Rightarrow 10x - 30 = 180^\circ$$

$$\Rightarrow 10x = 210^\circ$$

$$\Rightarrow x = 21$$

Now,

$$\text{Largest angle} = (5x - 18)^\circ$$

$$= 5 \times 21 - 18$$

$$= 105 - 18$$

$$= 87^\circ$$

$\therefore$  The largest angle of  $\Delta ABC$  is  $87^\circ$ .

**Que. 78 Select the related number from the given alternatives.**

**21 : 11 :: 19 : ?**

**1. 10**

**2. 25**

**3. 22**

**4. 41**

**Ans.**

Correct Option - 1

The logic is:

$$11 \times 2 = 22 - 1 = 21$$

Similarly,

$$10 \times 2 = 20 - 1 = 19$$

Hence the correct answer is 10.

**Que. 79** In which year did the Bhopal Gas Tragedy take place?

1. 1985
2. 1984
3. 1988
4. 1983

**Ans.** Correct Option - 2

The correct answer is 1984.

Considered to be the world's worst industrial disaster, the Bhopal gas tragedy took place on 2-3 December 1984 at the Union Carbide India Limited plant in Bhopal, Madhya Pradesh.

It was a gas leak incident in which a highly toxic gas called methyl isocyanate leaked from the pesticide plant and spread to the small towns near the plant. The death toll is estimated to be somewhere between 3,787 to 16000.

**Que. 80** If 30% students failed in History, 45% failed in Politics and 25% failed in both the subjects then how many students passed in both the subjects?

1. 60%
2. 45%
3. 50%
4. 40%

**Ans.** Correct Option - 3

Percentage of students failed in both the subjects = 25%

Percentage of students failed in History = 30%

Percentage of students failed in History only =  $30\% - 25\% = 5\%$

Percentage of students failed in Politics = 45%

Percentage of students failed in Politics only =  $45\% - 25\% = 20\%$

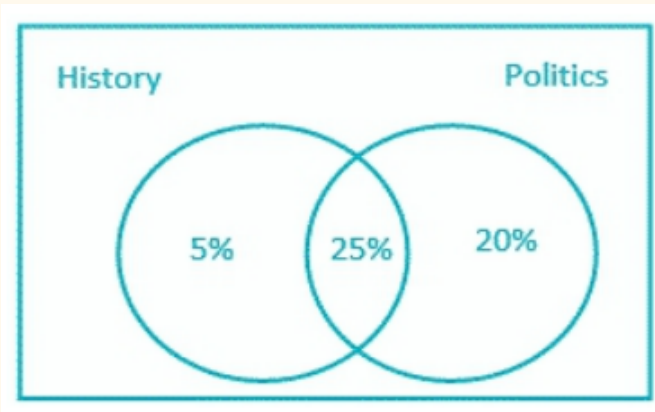

Now,

Percentage of students passed in both the subjects =  $100 - (5\% + 25\% + 20\%) = 50\%$

**Que. 81 Select the related letters from the given alternatives.**

**73 : 21 :: 48 : ?**

- 1. 12**
- 2. 32**
- 3. 51**
- 4. 20**

**Ans.** Correct Option - 2

The pattern followed here is:

73 is written as  $7 \times 3 = 21$

Similarly,

48 is written as  $4 \times 8 = 32$

Hence, 32 is the answer

**Que. 82 Chlorine gas is a major component of which of the following?**

- 1. Water**
- 2. Tear gas**
- 3. Liquefied Petroleum Gas**
- 4. Gobar gas**

**Ans.** Correct Option - 2

Chlorine gas is a major component of tear gas.

Tear gas comprises substances that irritate the eyes and its mucous membranes and cause tears and stinging sensation.

The major components of tear gas are o-chlorobenzylidenemalononitrile, or CS and  $\omega$ -chloroacetophenone, or CN.

Liquefied Petroleum Gas or LPG consists of butane or propane.

Gobar gas is also known as biogas. It is produced by breaking down organic matter in the absence of oxygen.

**Que. 83 If the operating cost of 6 burners for 6 hours in 8 days is Rs. 450 then find the number of burners if used for 5 hours for 10 day with operating cost of Rs.1250.**

- 1. 16**
- 2. 14**
- 3. 12**
- 4. 10**



**Ans.** Given: Correct Option - 1

6 burners are used for 6 hours for 8 days with an operating cost 450 Rs.

Concept used:

$$M_1 D_1 H_1 = M_2 D_2 H_2$$
$$W_1 \quad \quad W_2$$

Where  $M_1$  denotes the number of burners here.

$D_1$  denotes the number of Days and  $H_1$  the number of hours.

$W_1$  denotes the work in terms of rupees.

Calculation:

We have,

$$6 \times 6 \times 8 = x \times 5 \times 10$$

$$450 \quad \quad 1250$$

$$\Rightarrow x = 16$$

$\therefore$  The number of burners = 16.

**Que. 84** Four letter clusters have been given, out of which three are alike in some manner, while one is different. Select the odd letter cluster.

1. ACBD
2. PRQS
3. MONP
4. BCDE

**Ans.** Correct Option - 4

According to the English Alphabet series with positional value:

The pattern followed here is:

$$A + 2 = C \text{ and } B + 2 = D$$

$$P + 2 = R \text{ and } Q + 2 = S$$

$$M + 2 = O \text{ and } N + 2 = P$$

$$B + 1 = C \text{ and } D + 1 = E$$

All are having an addition of 2 except the last one having an addition of 1.

Hence, BCDE is the odd one.

**Que. 85** Which among the following gases is also known as 'Laughing Gas'?

1. Sulphur dioxide
2. Nitrous oxide
3. Carbon dioxide
4. Carbon monoxide

**Ans.** Correct Option - 2

Nitrous oxide is also known as "Laughing Gas".

The chemical formula of Nitrous oxide is  $N_2O$ .

It is a colorless, non-flammable gas at room temperature, with a faint metallic smell and taste.

It is a potent oxidizer similar to molecular oxygen at elevated temperatures.

It has important medical uses for its anesthetic and pain-reducing effects, especially in surgery and dentistry.

The name "Laughing Gas" is coined by Humphry Davy.

**Que. 86** When a number is divided by 7 it gives 3 as remainder. Find the total possible numbers between 1 to 100.

1. 10

2. 14

3. 18

4. 19

**Ans.** Given: Correct Option - 2

When a number is divided by 7 it gives 3 as the remainder.

Formula used:

$l = a + (n - 1) \times d$  (where  $l$ ,  $a$ ,  $n$  and  $d$  are last term, first term, number of terms and common difference respectively)

Calculations:

Required number =  $7x + 3$

Putting  $x = 0, 1, 2, \dots, 13$ , we get 3, 10, 17, .....94.

The required series is 3, 10, 17, .....94

$\Rightarrow a = 3, d = 7$  and  $l = 94$

$l = a + (n - 1) \times d$

$\Rightarrow 94 = 3 + (n - 1) \times 7$

$\Rightarrow n = 14$

$\therefore$  The total possible numbers satisfying the given conditions are 14

**Que. 87** Four numbers have been given, out of which three are alike in some manner, while one is different. Select the odd one.

1. 510

2. 612

3. 48

4. 31

**Ans.** Correct Option - 4

The pattern followed here is:

$$510 = 5 \times 2 = 10$$

$$612 = 6 \times 2 = 12$$

$$48 = 4 \times 2 = 8$$

$$31 \neq 3 \times 2$$

Hence, 31 is the odd one.

**Que. 88 Which is NOT an example of one-sided symbiotic relationship? 1. Cattle egrets and cattle**

**2. A hermit crab and an empty seashells**

**3. A spider on a tree**

**4. Tapeworm in host's stomach**

**Ans.** Correct Option - 4

The correct answer is Tapeworm in the host's stomach.

Tapeworm in the host's stomach is NOT an example of a one-sided symbiotic relationship (Commensalism).

Tapeworm in the host's stomach is an example of Parasitism.

Symbiosis is a close relationship between two species in which at least one species benefits. For the otherspecies, the relationship may be positive, negative, or neutral.

**Que. 89 If  $\sin A = 4/5$ , then find the value of  $(1 + \tan A)/(1 + \cot A)$ ?**

**1.  $7/3$**

**2.  $3/4$**

**3.  $4/7$**

**4.  $4/3$**

**Ans.** Given:

Correct Option - 4

$$\sin A = 4/5$$

Concept used:

$$\sin A = \text{Perpendicular} / \text{Hypotenuse}$$

Calculation:

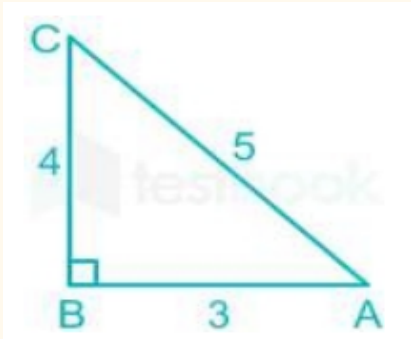

$$\sin A = \frac{4}{5}$$

$$BC = \sqrt{5^2 - 4^2} = \sqrt{25 - 16} = \sqrt{9} = 3 \quad [\text{Using Pythagorean triplets}]$$

Now,

$$\tan A = \frac{BC}{AB}$$

$$\Rightarrow \tan A = \frac{4}{3}$$

$$\cot A = \frac{AB}{BC}$$

$$\Rightarrow \cot A = \frac{3}{4}$$

$$\therefore \frac{(1 + \tan A)}{(1 + \cot A)}$$

$$\Rightarrow \frac{(1 + \frac{4}{3})}{(1 + \frac{3}{4})}$$

$$\Rightarrow \frac{(\frac{7}{3})}{(\frac{7}{4})}$$

$$\Rightarrow \frac{4}{3}$$

$\therefore$  The value of  $\frac{(1 + \tan A)}{(1 + \cot A)}$  is  $\frac{4}{3}$ .

**Que. 90 Directions:** In each of the following questions, the statement is given followed by two conclusions numbered I and II. You have to consider the statement to be true, even if it seems to be at variance from commonly known facts. You are to decide which of the given conclusions can be drawn definitely from the given statement.

**Statements:** During the lockdown, people started doing work from home. **Conclusions:**

I. People don't want to go to the office and like to stay at home.

II. Home gives a good environment to work and increases the productivity of the company.

1. Only I follows

2. only II follows

3. both I and II follow

4. neither I nor II follows

**Ans.** Correct Option - 4

Given:

**Statements:** During the lockdown, people started doing work from home. **Conclusions:**

I. People don't want to go to the office and like to stay at home. (False, there is no mention in the statement that people like to work at home and don't want to go to the office.)

II. Home gives a good environment to work and increases the productivity of the company.  
(False, maybe, home can give a good environment but whether it can increase the productivity of the company or not, is not discussed in the statement.)

Hence, neither I nor II follows

**Que. 91 Satya Nadella, is CEO of which of the following companies?**

1. Google
2. Microsoft
3. IBM
4. Apple

**Ans.** Correct Option - 2

The correct answer is option 2 i.e Microsoft

Microsoft

Microsoft is an American multinational company founded by Bill Gates and Paul Allen on April 4, 1975.

It develops, manufactures, licenses, supports, and sells computers, consumer electronics, and related services.

The products of Microsoft are Microsoft Windows, Operating system, Microsoft suite, Internet Explorer and Edge.

The CEO of Microsoft is Satya Nadella.

**Que. 92 What is the full form of MICR?**

1. Magnetic Ink Credit Recognition
2. Magnetic Ink Card Recognition
3. Magnetic Ink Character Recognition
4. Magnetic Ink Code Recognition

**Ans.** Correct Option - 3

The correct answer is Magnetic Ink Character Recognition.

MICR is used by the banking industry to ease the processing and clearance of cheques and other documents.

Numbers and characters found on the bottom of checks are printed using the Magnetic Ink. When a document that contains this ink needs to be read, it passes through a machine, which magnetizes the ink and then translates the magnetic information into characters.

**Que. 93 What is the SI unit of amount of substance?**

1. kg
2. g
3. mol
4. ton

**Ans.** Concept: Correct Option - 3

The quantity of matter contained in the body is known as Mass.

While weight is the force of gravity acting on the body.

The mass has only the magnitude but the weight has both magnitude and direction.

The SI unit of mass is the kilogram (kg) and the CGS unit is gram (g) .

The amount of substance is a physical quantity which gives a measure of the size of a group of entities like electrons, molecules, atoms, etc.

The SI unit of the amount of substance is mole (mol).

1 mol =  $6.022 \times 10^{23}$  particles

**Que. 94 Who was the first to propose Atomic Theory?**

1. J.J. Thomson
2. Rutherford
3. John Dalton
4. Neils Bohr

**Ans.** Correct Option - 3

The correct answer is option 3, i.e. John Dalton.

John Dalton was the First to propose Atomic Theory

**Que. 95 Which instrument is used for viewing the sun?**

1. Stroboscope
2. Telescope
3. Helioscope
4. Sun meter

**Ans.** Concept: Correct Option - 3

Helioscope was first used by Benedetto Castelli in 1578

Since observing sun directly can damage eyesight and its difficult to observe anything directly in Helioscope Sunlight is projected on a white sheet of paper with a help of telescope-like equipment and then any changes like eclipse can be observed easily by observing the sheet

Explanation:

A helioscope is an instrument used for observing the sun and sunspots.

The helioscope was first used by Benedetto Castelli and refined by Galileo Galilei.

**Que. 96 Tyre Park is located in which of the following states?**

- 1. West Bengal**
- 2. Madhya Pradesh**
- 3. Arunachal Pradesh**
- 4. Maharashtra**

**Ans.** Correct Option - 1

The correct answer is West Bengal.

West Bengal will soon feature "India's first" 'Tyre Park', where artworks made from scrap and defective parts will be on display, a state minister said.

Asserting that it is a unique concept, and not found anywhere in the country, the official said the idea behind the park is that waste can be converted into art.

**Que. 97 Which of the following places has India's first garbage cafe?**

- 1. Chattisgarh**
- 2. Jharkhand**
- 3. Kerala**
- 4. Kanpur**

**Ans.** Correct Option - 1

The correct answer is Chattisgarh.

The country's first garbage cafe has been launched here in Chhattisgarh.

Under this, the Municipal Corporation will provide food to the poor and homeless in lieu of plastic waste.

The cafe, situated in Ambikapur, which bagged the title of the second cleanest city in India, through the initiative, will provide impetus to Prime Minister Narendra Modi's 'plastic-free' India resolve.

**Que. 98 Who was the founder of Khalsa Panth?**

- 1. Guru Nanak Dev**
- 2. Guru Arjun Dev**
- 3. Guru Teg Bahadur**
- 4. Guru Gobind Singh**

**Ans.** Correct Option - 4

The correct answer is Guru Gobind Singh.

Khalsa tradition was initiated in 1699 by the Tenth Guru of Sikhism, Guru Gobind Singh. Its formation was a key event in the history of Sikhism.

The founding of Khalsa is celebrated by Sikhs during the festival of Vaisakhi.

**Que. 99 The United Nations Charter was signed by 51 original members of the United Nations in 1945 at \_\_\_\_\_.**

1. Hague Conference
2. London Conference
3. San Francisco Conference
4. Berlin Conference

**Ans.** Correct Option - 3

The correct answer is the San Francisco Conference.

The United Nations Charter was signed by 51 original members of the United Nations in 1945 at the SanFrancis conference 850 delegates from 51 nations deliberated, discussed, and finalized the charter which initially led into 4 sections.

It was passed unanimously on 26th June 1945.

**Que. 100 Who among the following is a current non-permanent member of the UN Security Council?**

1. Pakistan
2. Australia
3. India
4. All of these

**Ans.** Correct Option - 3

The correct answer is India.

India is a current non-permanent member of the UN Security Council.

The United Nations Security Council is one of the six main organs of the UN, and it is primarily responsible for maintaining international peace and security.

It consists of 15 members -five permanent members and 10 non-permanent members. The five permanent members are the US, UK, Russia, China and France.

Every year, five non-permanent members are elected for a tenure of two years. To be elected as a non-permanent member of the council, each member-country requires a two-third majority of the entire assembly.



India was the sole candidate for a non-permanent seat from the Asia-Pacific category for the 2021-22 term.

India got 184 out of the 192 valid votes polled and got a seat of non-permanent member of UNSecurityCouncil.

Previously, India had been elected as a non-permanent member of the Council for the years 1950-1951, 1967-1968, 1972-1973, 1977-1978, 1984-1985, 1991-1992 and 2011-2012.

The subsidiary bodies of the council are known as committees: Counter-TerrorismCommittee, Non- Proliferation Committee, United Nations Military Staff Committee and Sanctions Committee. The council uses sanctions to put pressure on a country to comply with its objectives, without using force.