

Engineering Services (Main)  
Examination - 2025

वियोज्य **DETACHABLE**

## CIVIL ENGINEERING

### Paper II

Time Allowed : Three Hours

Maximum Marks : 300

#### QUESTION PAPER SPECIFIC INSTRUCTIONS

Please read each of the following instructions carefully before attempting questions :

There are **EIGHT** questions divided in **TWO** sections.

Candidate has to attempt **FIVE** questions in all.

Questions No. **1** and **5** are **compulsory** and out of the remaining, **THREE** are to be attempted choosing at least **ONE** question from each section.

The number of marks carried by a question/part is indicated against it.

Wherever any assumptions are made for answering a question, they must be clearly indicated.

Diagrams/Figures, wherever required, shall be drawn in the space provided for answering the question itself.

Unless otherwise mentioned, symbols and notations have their usual standard meanings.

Attempts of questions shall be counted in sequential order. Unless struck off, attempt of a question shall be counted even if attempted partly.

Any page or portion of the page left blank in the Question-cum-Answer Booklet must be clearly struck off.

Answers must be written in **ENGLISH** only.

## SECTION 'A'

- 1.(a) A 30 cm diameter well completely penetrates a confined aquifer of permeability 60 m/day. Under steady state of pumping, the drawdown at the well was observed to be 4.5 m and the discharge was 2100 lpm for a radius of influence of 450 m.

If someone says “double the diameter of the well to 60 cm to get double discharge”, will it be correct ?

Compute the discharge for 60 cm diameter well and the percentage increase in the discharge. All other data remains the same. 12

- 1.(b) Describe briefly (1-2 sentences each) with sketch the following hydroelectric power plants :

- (i) Run-of-River plant
- (ii) Valley Dam plant
- (iii) Diversion Canal plant
- (iv) High head diversion plant 12

- 1.(c) Consider a  $50^\circ$  triangular channel having a flow rate  $Q = 16 \text{ m}^3/\text{s}$  and  $n = 0.018$ . Compute

- (i) the critical depth
- (ii) critical velocity, and
- (iii) critical slope

Take  $\alpha = 1.0$  and  $g = 9.81 \text{ m/s}^2$

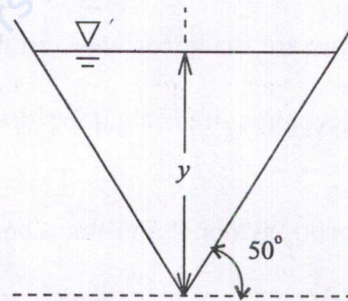

12

- 1.(d) A water sample was analysed in the laboratory and the following were reported :

$\text{HCO}_3^- = 300 \text{ mg/l}$ ;  $\text{Na}^+ = 115 \text{ mg/l}$ ;  $\text{SO}_4^{2-} = 240 \text{ mg/l}$ ;  $\text{Mg}^{+2} = 36.6 \text{ mg/l}$ ;  
 $\text{Cl}^- = 71 \text{ mg/l}$ ;  $\text{Ca}^{+2} = 100 \text{ mg/l}$ .

Find the % error in cation-anion balance. Also draw a bar diagram to indicate cation-anion balance. Comment on the Result of cation-anion balance error %.

12

1.(e) Data pertaining to a conventional ASP is given below :

Population of town	= 10 lakhs
Wastewater contribution	= 100 lpcd
BOD in settled sludge	= 180 mg/l
Effluent BOD required	= 30 mg/l
F/M ratio	= 0.2
MLSS concentration	= 2800 mg/l
SVI	= 100

Find the volume of aerator, Hydraulic Retention time (HRT), Volumetric loading and Return Sludge Ratio. Also comment if the parameters match with design conditions.

12

2.(a)(i) In a water treatment plant which treats 10 MLD of water, it is proposed to design a circular PST and RSF. Using the data given below, find

(A) Surface area, DT (Detention Time) of the PST and diameter

(B) Horizontal velocity

(C) Surface area of RSF

(D) No. of filter units

PST surface loading	= 50 m <sup>3</sup> /m <sup>2</sup> /day
Depth of PST	= 2.5 m
Rate of filtration	= 5000 l/m <sup>2</sup> /hr
Quantity of backwash water	= 15%
Time for backwashing	= 1 hr

12

2.(a)(ii) Explain the mechanisms responsible for removal of colloidal solids by coagulation.

8

2.(b) Determine the area required for a proposed landfill for a town with population of 5 lakhs. The per capita waste generation is about 0.5 kg. It is proposed that the landfill life to be 30 years with maximum height of 20 m. Density of compacted waste is 450 kg/m<sup>3</sup>. Assume ratio of solid waste to soil cover as 4 : 1.

20

2.(c) A 4.0 m wide rectangular channel has a flow of 4.80 m<sup>3</sup>/s with a velocity of 0.8 m/s. After a heavy rainfall event in the upstream catchment, a sluice gate on the upstream is suddenly raised. This causes a surge to travel downstream and a quick increase in depth by 50%. Calculate the absolute velocity of the resulting surge and the new flow rate. Given  $g = 9.81 \text{ m/s}^2$ .

20

3.(a) A dam discharges  $254.7 \text{ m}^3/\text{s}$  of water over the spillway. The flow then passes over a level concrete apron ( $n = 0.013$ ). The velocity of water at the bottom of the spillway is  $12.8 \text{ m/s}$  and the width of the apron is  $54.86 \text{ m}$ . The flow conditions produce a hydraulic jump, the depth in channel below the apron being  $3.05 \text{ m}$ .

- (i) If the jump has to be contained in the apron, how long should the apron be built? Take  $g = 9.81 \text{ m/s}^2$ ;  $\rho = 1000 \text{ kg/m}^3$ . 15
- (ii) How much energy is lost from the foot of the spillway to the downstream side of jump? 5

3.(b)(i) A Pelton wheel has to be designed for the following specifications :

Power to be developed	= 6000 kW
Net head available	= 300 m
Speed	= 550 RPM
Ratio of jet diameter to wheel diameter	= 1/10
Hydraulic efficiency	= 0.85
Velocity coefficient $C_v$	= 0.98
Speed Ratio $\phi$	= 0.46
$\rho$	= $1000 \text{ kg/m}^3$
$g$	= $9.81 \text{ m/s}^2$

- Determine (A) the required discharge,  
 (B) diameter of the wheel,  
 (C) diameter of each jet, and  
 (D) the number of jets. 10

3.(b)(ii) With the help of sketches, explain in one or two sentences the difference between the following cross-drainage works :

- (A) syphon aqueduct and canal syphon  
 (B) aqueduct and superpassage 10

3.(c)(i) An industry consumes  $10,000 \text{ lit.}$  of fuel per day for generation of steam. Based on quality of the fuel, the emission data indicates the following average emissions for  $1 \text{ ML}$  of fuel consumed per year.

$$\text{SPM} = 3 \text{ t/yr}; \text{SO}_2 = 75 \text{ t/yr}; \text{NO}_x = 12 \text{ t/yr}; \text{HC} = 0.6 \text{ t/yr}; \text{CO} = 0.75 \text{ t/yr}.$$

Determine the height of the chimney required for the industry. 10

- 3.(c)(ii) Explaining the major causes for noise pollution, discuss methods used for control of noise pollution in industries. 10
- 4.(a) Using the data given below, estimate
- Volume of fresh sludge produced
  - Unit weight of raw sludge
  - Volume of digested sludge
- |  |            |    |
|--|------------|----|
| Wastewater discharge                           | = 2 MLD    |    |
| Influent suspended solids                      | = 200 mg/l |    |
| Suspended solids removal in PST                | = 60%      |    |
| Specific gravity of solids                     | = 1 : 2    |    |
| Moisture content of digested sludge            | = 90%      |    |
| % conversion of fresh sludge to liquid and gas | = 50%      |    |
| Moisture content of fresh sludge               | = 96%      | 20 |
- 4.(b) A rectangular pier in a river is 1.22 m wide by 3.66 m long, and the average depth of water is 2.74 m. A model is built to a scale of 1 : 16. A velocity of flow of 0.076 m/s is maintained in the model, and the force acting on the model is 4.0 N.
- What are the values of velocity in and force on the prototype ?
  - If a standing wave in the model is 0.049 m high, what is the height of wave at the nose of the pier ?
  - What is the coefficient of drag resistance ?
- Take density of water  $\rho = 1000 \text{ kg/m}^3$ . 20
- 4.(c)(i) What are the various components of diversion headworks ? Describe each in one or two sentences. 10
- 4.(c)(ii) With help of a flow chart, explain various components of an Ecosystem and their functions. 10

### SECTION 'B'

- 5.(a) A circular loaded area with radius 5 m is subjected to a load of  $500 \text{ kN/m}^2$ . Calculate and compare the variation of vertical stress below the centre of the circular area using Boussinesq's theory and Westergaard's theory for the depth from ground level to 10 m below the ground surface. Assume Poisson's ratio as 0.30. 12

5.(b) At a site the data related to a normally consolidated clay layer is as follows :

Thickness of the clay layer	=	3.0 m
Initial void ratio	=	0.85
Compression index	=	0.27
Average effective pressure on the clay layer	=	130 kN/m <sup>2</sup>

Increment of pressure due to construction of foundation with load of superstructure is 300 kN/m<sup>2</sup>.

The secondary compression index  $C_{\alpha} = 0.02$ . What is the total consolidation settlement of the clay layer five years after the completion of primary consolidation settlement? The time of completion of primary settlement is 2 years. 12

5.(c) An expressway passing through a rolling terrain has a horizontal curve of radius equal to the ruling minimum radius. Design the following geometric elements of this expressway for ruling design speed of 100 kmph, assuming any missing data suitably :

- (i) Ruling minimum radius
- (ii) Super elevation
- (iii) Extra widening
- (iv) Length of transition curve
- (v) SSD, ISD and set-back distance
- (vi) The minimum set-back distance from the center line of the two lane expressway on the inner side of the curve to provide a clear vision assuming the length of circular curve greater than the sight distance. 12

5.(d) Find out the steepest gradient on a straight track using the following data for a train having 25 wagons :

Weight of each wagon	=	20 tonnes
Rolling resistance of wagon	=	2.5 kg/tonne
Speed of the train	=	60 kmph
Weight of locomotive with tender	=	120 tonnes
Tractive effort of locomotive	=	45 tonnes
Rolling resistance of locomotive	=	3.5 kg/tonne

12

5.(e)(i) Distinguish clearly between mistake and error. Also differentiate between systematic and accidental errors. How the most probable values of a single observation and the mean of a number of observations are computed? 6

- 5.(e)(ii) A distance of 1500 m was measured by a 30 m chain. Later, it was detected that the chain was 8 cm too long. Thereafter, another 1000 m was measured and it was detected that the chain was 12 cm too long. If the chain was correct initially, determine the exact length that was measured. 6

- 6.(a)(i) The following are the bearings taken on a closed compass traverse :

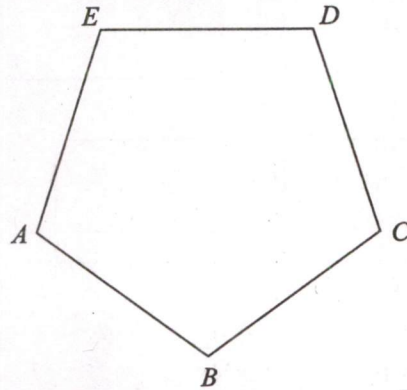

<i>Line</i>	<i>Fore Bearing</i>	<i>Back Bearing</i>
AB	82°30'	260°40'
BC	122°20'	303°40'
CD	172°50'	352°30'
DE	232°10'	51°30'
EA	312°20'	132°10'

Compute the interior angles and correct them for observational errors. If the observed bearing of the line BC is correct, adjust the bearings of the remaining sides. 10

- 6.(a)(ii) Define the following terms used in aerial survey :

- (I) Fiducial marks
- (II) Isocentre
- (III) Relief Displacement
- (IV) Tilt and Tip
- (V) Principal point

10

- 6.(b) Write descriptive notes on :

20

- 6.(b)(i) Environmental impacts associated with airport projects

5

- 6.(b)(ii) Parking configurations for aircrafts

5

- 6.(b)(iii) Cross wind component

5

- 6.(b)(iv) Typical layout of an artificial harbour indicating the components and their functions

5

- 6.(c) Determine the safe gross inclined load for a square footing as shown in the diagram.

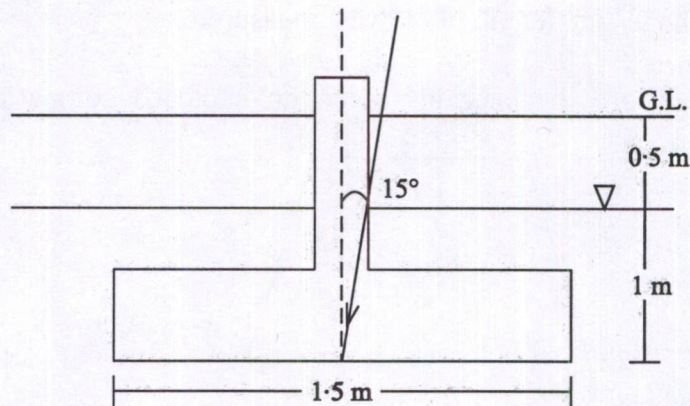

The base of the foundation is 1.5 m below ground level and depth of water table is 0.5 m below ground level.

The properties of the soil are as follows :

Cohesion	=	0
Angle of shearing resistance	=	30°
Bulk density	=	16.5 kN/m <sup>3</sup>
Saturated density	=	19.5 kN/m <sup>3</sup>

The values of non-dimensional bearing capacity factors are :  
 $N_c = 37.16$ ,  $N_q = 22.46$  and  $N_\gamma = 19.13$ .

20

- 7.(a) A mat foundation is to be laid at a depth of 2 m below ground surface in a 20 m thick layer of normally consolidated clay underlain by dense sand. The mat foundation is supported by a group of 16 piles of length 12 m and diameter 400 mm arranged in a square pattern. The gross load to be carried by the pile group is 3000 kN. The piles are spaced at 1.2 m c/c. The water table is at ground surface. The geotechnical properties of the foundation soil are as follows :

Water content = 30%, Specific gravity = 2.65, Liquid limit = 40%

Determine the probable consolidation settlement of the pile group. While estimating the settlement divide the sublayers into three zones suitably.

20

- 7.(b) A retaining wall of 5 m height has to retain a stratified backfills. The properties of different layers of backfills are shown in following table :

<i>Properties</i>	<i>Top layer</i>	<i>Middle layer</i>	<i>Bottom layer</i>
Thickness (m)	2	1	2
Density (kN/m <sup>3</sup> )	18.5	17.2	18.8
Types of soil	Sandy silt	Loose sand	Dense sand
Cohesion (kN/m <sup>2</sup> )	10	0	0
Angle of shearing resistance (degree)	20°	30°	38°

Determine the magnitude of total active pressure on the wall and its point of application. 20

- 7.(c)(i) Briefly describe the Track Management System (TMS). What are the main advantages of TMS ? 10

- 7.(c)(ii) What is the role of ground water in the success of tunnelling ? Explain the bearing of lithology and geological structures in this context. 10

- 8.(a) A CC pavement slab of thickness 20 cm is constructed over a granular sub-base having modulus of reaction 15 kg/cm<sup>2</sup>. The maximum temperature difference between the top and bottom of the slab during summer day and night is found to be 18°C. The spacing between the transverse contraction joint is 4.5 m and that between longitudinal joint is 3.5 m. The design wheel load is 5100 kg, radius of contact area is 15 cm, E value of CC is  $3 \times 10^5$  kg/cm<sup>2</sup>, Poisson's ratio is 0.15 and coefficient of thermal expansion of CC is  $10 \times 10^{-6}$  per °C and friction coefficient is 1.5. Using the edge and corner load stress charts given by IRC and the chart for the warping stress coefficient (given below), find the worst combination of stresses at the edge. 10

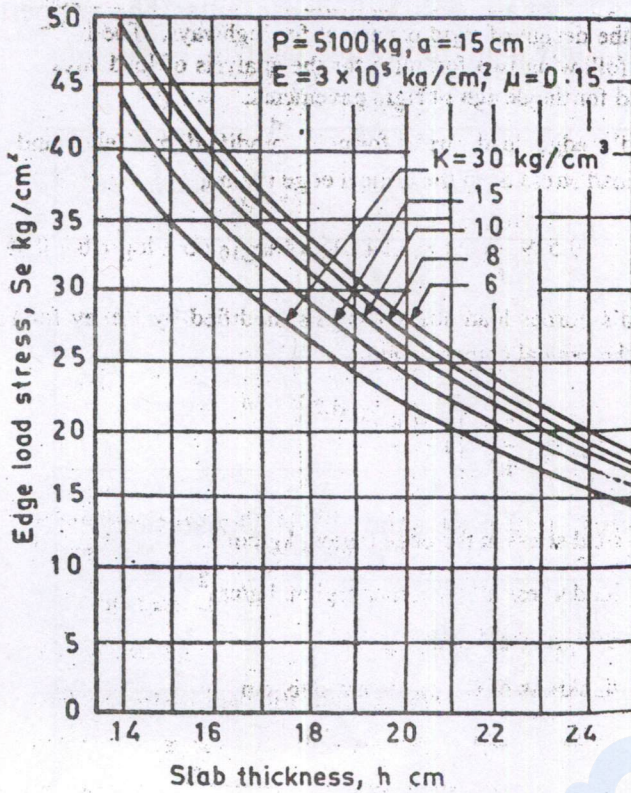

C-1 - Edge Load Stress Chart (IRC)

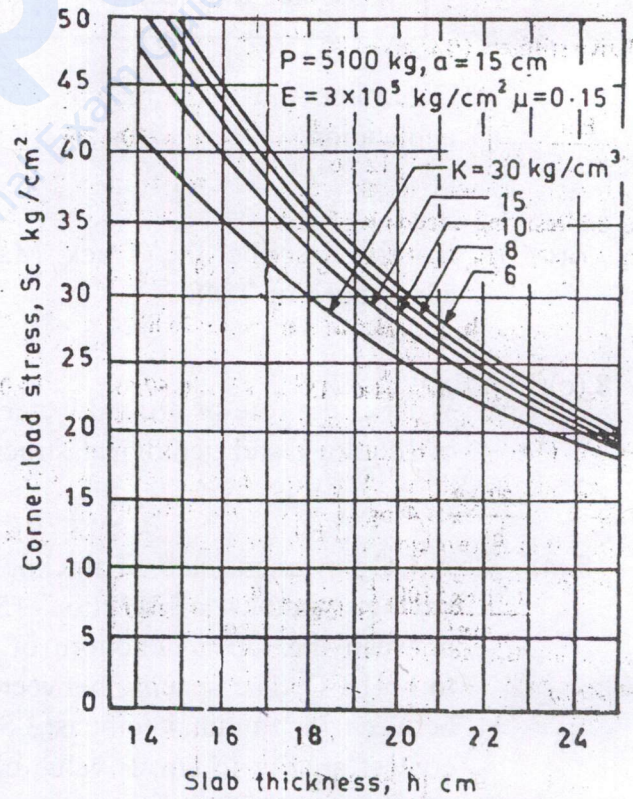

C-2 - Corner Load Stress Chart (IRC)

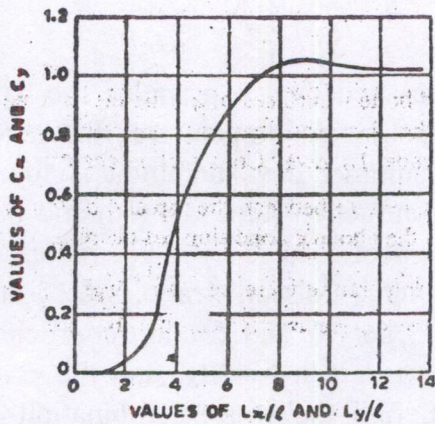

C-3 - Warping Stress Coefficient



**prepp**  
Your Personal Exam Guide