

Engineering Services (Main)
Examination - 2025

NESP-O-ELEE

ELECTRICAL ENGINEERING

PAPER—I

Time Allowed : Three Hours

Maximum Marks : 300

QUESTION PAPER SPECIFIC INSTRUCTIONS

Please read each of the following instructions carefully before attempting questions

There are **EIGHT** questions divided in **TWO** Sections.

Candidate has to attempt **FIVE** questions in all.

Question Nos. **1** and **5** are compulsory and out of the remaining, **THREE** are to be attempted choosing at least **ONE** question from each Section.

The number of marks carried by a question/part is indicated against it.

Wherever any assumptions are made for answering a question, they must be clearly indicated.

Diagrams/Figures, wherever required, shall be drawn in the space provided for answering the question itself.

Unless otherwise mentioned, symbols and notations have their usual standard meanings.

Attempts of questions shall be counted in sequential order. Unless struck off, attempt of a question shall be counted even if attempted partly.

Any page or portion of the page left blank in the Question-cum-Answer Booklet must be clearly struck off.

Answers must be written in **ENGLISH** only.

SECTION—A

1. (a) (i) If A is an $n \times n$ diagonalizable matrix and $A^2 = A$, then show that each eigenvalue of A is 0 or 1.
- (ii) Show that all the eigenvalues of a Hermitian matrix are real. 6+6=12
- (b) The magnetic field strength in a material is 9×10^5 A/m and its magnetic susceptibility is 0.75×10^{-5} .
- (i) Find the flux density and the magnetization in the material.
- (ii) Also find its relative permeability. 12

- (c) For the circuit given in the figure below, find the current through 4Ω resistor and the total active power delivered by the source. The source voltage $v_s(t) = 50 \cos 2\sqrt{2}t + 10 \cos \frac{1}{\sqrt{2}}t$ volts :

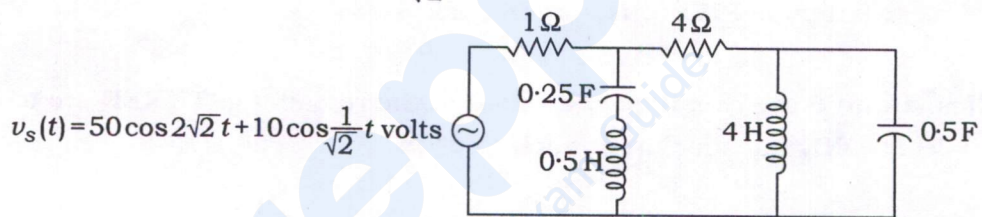

12

- (d) Consider the circuit shown in the figure below. Assuming that the diodes are ideal, sketch the following waveforms :
- (i) Two cycles of V_i (input) and V_o (output)
- (ii) Transfer characteristics of the circuit, i.e., V_o versus V_i

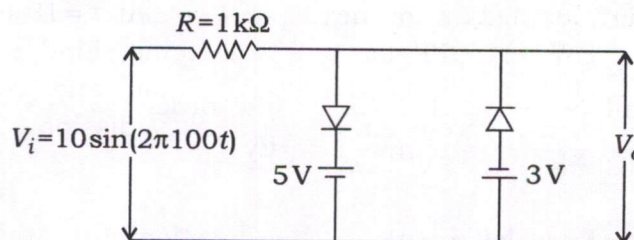

12

- (e) Draw the circuit diagram and explain the process of measurement of low resistance values using Kelvin's double bridge. Derive the expression and mention two conditions which ensure that the unknown resistance can be easily measured in terms of the standard resistance. 12

2. (a) (i) What are Lissajous patterns? Explain. Also elaborate what patterns appear on the cathode ray oscilloscope screen, when voltages of different frequencies and phase differences are applied in the horizontal and vertical plates of the scope. Take two examples for each of the above two cases. Explain how the unknown signal frequency is measured accurately with the help of observing the patterns. 12

- (ii) Explain the principle of operation of a piezoelectric transducer. Write its advantages, disadvantages and some applications. 8

- (b) (i) Write a program in C language to print the following full pyramid of numbers :

```

      1
     2 3 2
    3 4 5 4 3
   4 5 6 7 6 5 4
  5 6 7 8 9 8 7 6 5
  
```

10

- (ii) Minimize the four-variable logic function using K-map

$$f(A, B, C, D) = \sum m(0, 1, 2, 3, 5, 7, 8, 9, 11, 14)$$

10

- (c) A cardiac pacemaker is represented by the circuit given in the figure below. The battery internal resistance R_b is $10\text{ m}\Omega$, whereas the heart equivalent resistance is $1\text{ k}\Omega$. The switch 1 (SW1) is at position a initially for a long time when switch 2 (SW2) is OFF. Then SW1 is moved to position b at $t=0$ and SW2 is ON simultaneously for next $t=10\text{ ms}$. At $t=10\text{ ms}$, SW1 moves to position a and SW2 is OFF for another 10 ms . Find the voltages of the capacitors C_1 and C_2 at $t=0, 10\text{ ms}$ and 20 ms , and sketch the capacitor voltages up to 20 ms . Also calculate the energy dissipated in R_L during the interval 0 to 10 ms when SW2 was ON :

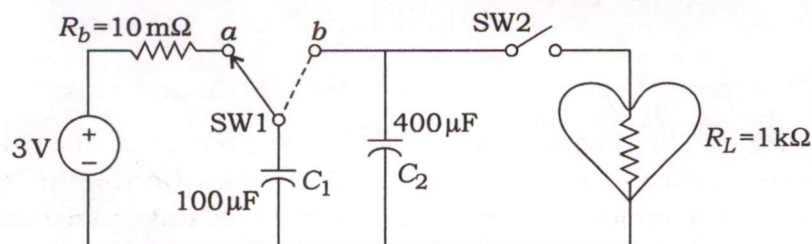

20

3. (a) (i) Find the singular solution of the partial differential equation

$$6yz - 6pxy - 3qy^2 + pq = 0$$

10

- (ii) Derive the formula by Newton-Raphson method to find next approximation of the root of the equation $f(x) = 0$, if x_0 is an initial approximation. Also perform three iterations to find a root of the equation $x^4 - x - 10 = 0$ which is near to $x = 2$, correct to three decimal places.

4+6=10

- (b) (i) Prove that the susceptibility of a perfectly superconducting material is -1 and its relative permeability is zero.

8

- (ii) Find the critical current and critical current density at temperature 4.2 K for a superconducting wire made of lead with a diameter of 2 mm. The critical temperature for lead is 7.2 K and its critical field is $H_0 = 6.5 \times 10^4$ A/m.

12

- (c) Consider the circuit shown in the figure below :

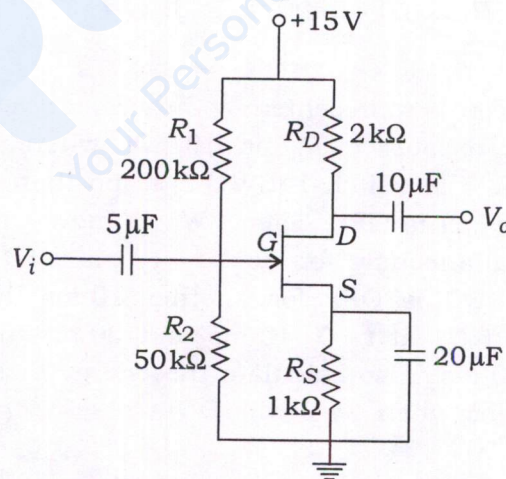

- (i) Determine Q -point of the circuit by assuming maximum drain current $I_{DSS} = 8$ mA and pinch-off voltage $V_p = -4$ V.
- (ii) Plot the transfer characteristics and DC load line, and indicate the Q -point.

20

4. (a) (i) In a factory, there are following two loads :

Lighting and heating load : 100 kW

Induction motor load : 1000 HP at 0.7 lagging power factor and 85% efficiency

The overall load power factor of the factory has to be raised to 0.95 lagging. A 3-phase synchronous motor is installed for the above purpose. The motor is rated at 300 HP with 100% efficiency. Find the kVA rating of the synchronous motor. Also find the power factor of the synchronous motor. Given 1 HP (horsepower) = 746 watts.

12

- (ii) Two single-phase ideal voltage sources are connected by a line of impedance of $(0.7 + j2.4)$ ohms as shown in the figure below. Given $V_1 = 500\angle 16.26^\circ$ volts and $V_2 = 585\angle 0^\circ$ volts. Find the complex power for each source and determine whether they are delivering or receiving real and reactive power. Also find the real and reactive power losses in the line :

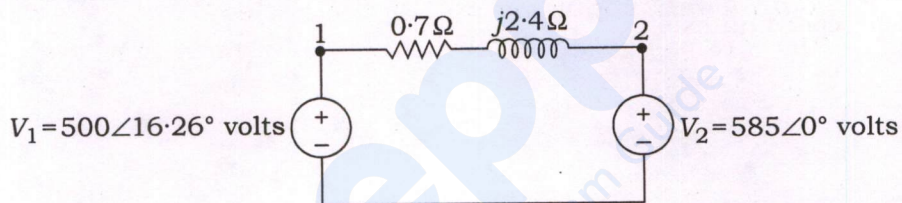

8

- (b) A priority encoder truth table is given below :

Inputs				Outputs		
I_0	I_1	I_2	I_3	x	y	z
1	x	x	x	0	0	1
0	1	x	x	0	1	1
0	0	1	x	1	0	1
0	0	0	1	1	1	1
0	0	0	0	x	x	0

Obtain the minimized Boolean expressions for x , y and z outputs. Design a combinational circuit for the minimized Boolean expressions of x , y and z . Consider that x is don't care.

20

- (c) (i) A uniform volume charge density of $0.8 \mu\text{C}/\text{m}^3$ is present throughout the spherical shell extending from $r = 3 \text{ cm}$ to $r = 5 \text{ cm}$. If the volume charge density is zero elsewhere, find the total charge present throughout the shell. If the half of the total charge is located in the region where the radius varies as $3 \text{ cm} < r < r_1$, find the value of r_1 in cm. 10

- (ii) A current filament on the z -axis carries a current of 7 mA in the a_z direction and current sheets of $0.5 a_z \text{ A/m}$ and $-0.2 a_z \text{ A/m}$ are located at $\rho = 1 \text{ cm}$ and $\rho = 0.5 \text{ cm}$ respectively. What is the value of H at $\rho = 4 \text{ cm}$? What value of current sheet should be located at $\rho = 4 \text{ cm}$ so that $H = 0$ for all $\rho > 4 \text{ cm}$?

Given, H : magnetic field intensity; ρ : radius variable of cylindrical coordinates. 10

SECTION—B

5. (a) For the circuit shown in the figure below, the two magnetically coupled coils have mutual inductance $M = 4 \text{ mH}$. The self-inductances are $L_1 = 80 \text{ mH}$ and $L_2 = 8.2 \text{ mH}$ respectively. The source voltage is $v_s(t) = 100 \sin 5000t$ volts with a source resistance of 1Ω and inductance of 1 mH . Find the power delivered by the source and the corresponding source power factor when the connected load with the second coil is a capacitor C of $5 \mu\text{F}$ as shown in the figure :

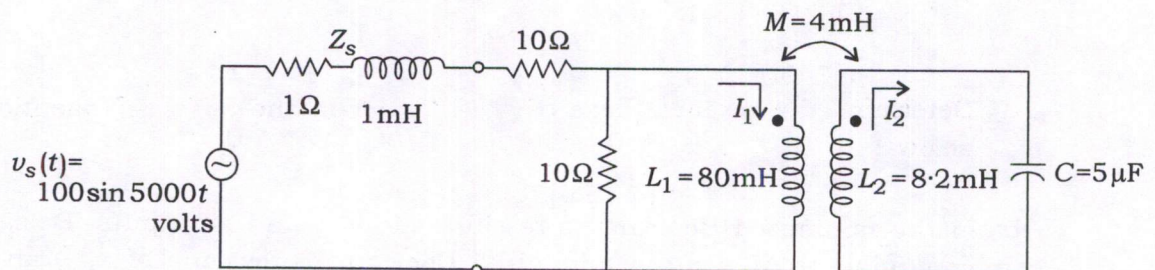

12

- (b) Given, $\mu = 3 \times 10^{-5}$ H/m, $\epsilon = 1.2 \times 10^{-10}$ F/m and $\sigma = 0$ everywhere. If $H = 2 \cos(10^{10}t - \beta x) \bar{a}_z$ A/m, use Maxwell's equations to obtain the expressions for B , D , E and β .

Given, μ : Permeability

ϵ : Permittivity

B : Flux density

H : Magnetic field intensity

E : Electric field intensity

D : Electric flux density

β : Phase constant

12

- (c) Identify the names of the following electronic devices, mark their terminals and plot their transfer characteristics :

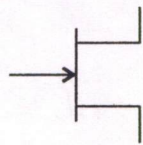

(i)

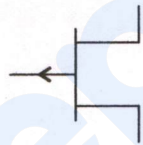

(ii)

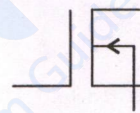

(iii)

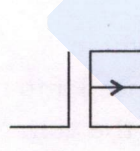

(iv)

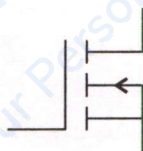

(v)

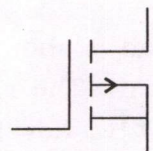

(vi)

12

- (d) If the probability of a bad reaction from certain injection is 0.001, determine the chance that out of 2000 persons, more than two will get a bad reaction. 12

- (e) (i) Determine the possible base of the number in the operation mentioned below :

$$23 + 44 + 14 + 32 = 223$$

- (ii) Find the number of divisors and sum of divisors of 4900.

6+6=12

6. (a) (i) Explain the principle on which a Q -meter works. Describe briefly the direct connection, series connection and parallel connection of using the Q -meter. Also mention for which types of loads, these connections are used. 12

- (ii) A power transformer was tested to determine losses and efficiency. The input power was measured as 3650 watts and the delivered output power was 3385 watts, with each reading in doubt by ± 10 watts. Calculate (1) the percentage uncertainty in losses of the transformer and (2) the percentage uncertainty in the efficiency of the transformer, as determined by the difference in input and output power readings. 8

- (b) (i) An electric field in x - y plane is given by $f(x, y) = 3x^2y - y^3$. Find the stream function $g(x, y)$ such that the complex potential $w = f + ig$ is an analytic function. 10

- (ii) Find the mass of the surface of the cone $z = 2 + \sqrt{x^2 + y^2}$, $2 \leq z \leq 7$ in the first octant, if the density $\rho(x, y, z)$ at any point of the surface is proportional to its distance from x - y plane. 10

- (c) A balanced load is shown in the figure below, where $R = 30 \Omega$, $C = 159.15 \mu\text{F}$ and $L = 95.5 \text{ mH}$. The r.m.s. value of the balanced input supply voltage is 415 V (L-L), 50 Hz. Now find (i) the magnitude of the voltage V_{ab} , (ii) the phase of V_{ab} with respect to V_{AB} and (iii) the total power supplied to the load and corresponding power factor calculated from source side :

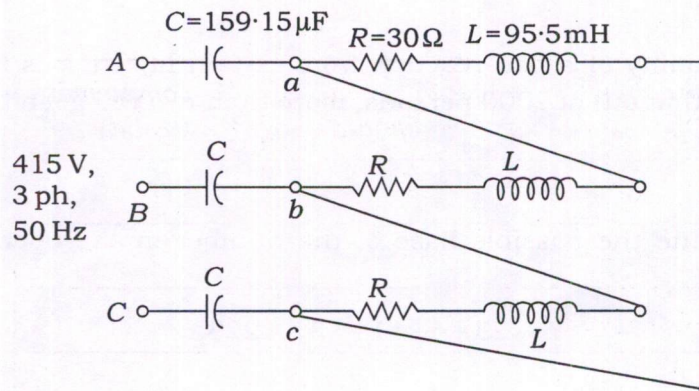

20

7. (a) Consider the silicon transistor circuit shown in the figure below. The data pertaining to transistors are as follows :

(i) $\beta = 100$, (ii) maximum drain current $I_{DSS} = 6 \text{ mA}$, (iii) pinch-off voltage $V_p = -2 \text{ V}$

Determine the voltage V_D .

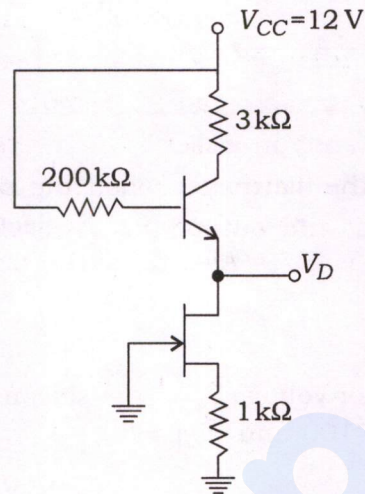

20

- (b) A conducting wire has resistivity of $1.57 \times 10^{-8} \Omega\text{-m}$ at room temperature. There are 5.85×10^{28} number of conducting electrons per m^3 for the material at room temperature. For an electric field of 1.1 V/cm along the wire, calculate the (i) drift velocity, (ii) relaxation time, (iii) mobility and (iv) mean free path for the conducting electrons in the material.

(Assume charge of electron = $1.609 \times 10^{-19} \text{ C}$, mass of electron = $9.11 \times 10^{-31} \text{ kg}$, velocity of electrons $v = 3 \times 10^8 \text{ m/s}$ and isotropic scattering)

20

- (c) (i) Differentiate between isolated I/O and memory-mapped I/O with their advantages and disadvantages.
- (ii) Represent the following numbers and arithmetic operations given in the table :

8

Numbers / Operations	8-bit signed magnitude	1's complement (8-bit)	2's complement (8-bit)
+68			
-83			
(+68) + (-83)			
(-68) + (+83)			

12

8. (a)

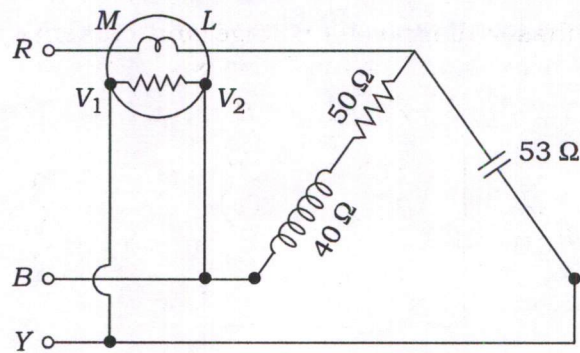

Find the reading of the wattmeter when the network shown is connected to a symmetrical 440 V, 3-phase supply. Neglect all losses in the instrument. The phase sequence is RYB. Also draw the phasor diagram of the network. 20

(b) Determine the collector voltage V_C of the silicon transistor circuit shown in the figure below, if (i) $\beta = 100$ and (ii) $\beta = 50$:

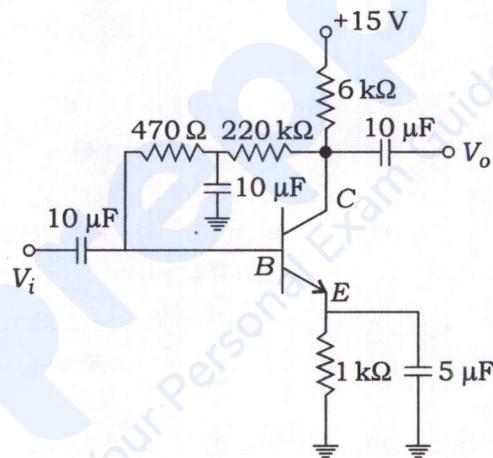

20

(c) Voltmeters are connected across the resistance $R = 1 \Omega$ and load impedance Z_L and a wattmeter is connected at the input side of the circuit as shown in the figure below. The source voltage is 230 V, 50 Hz and the voltmeters read $V_R = 10 \text{ V}$, $V_L = 225 \text{ V}$.

(i) Find the wattmeter reading, source current and input power factor with the same supply voltage and frequency.

(ii) Find the voltmeter and wattmeter readings when the supply frequency is changed to 60 Hz at same supply voltage of 230 V.

(iii) Draw the phasor diagram of voltage and currents for (i) above.

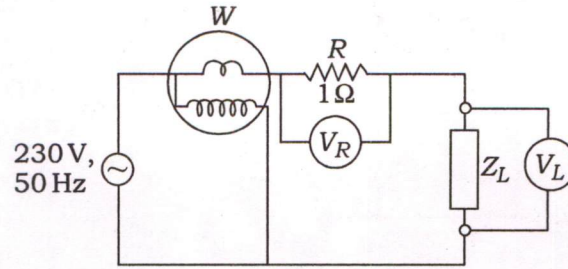

20

prepp
Your Personal Exam Guide