

**MECHANICAL ENGINEERING**  
**Paper II**

Time Allowed : Three Hours

Maximum Marks : 300

**QUESTION PAPER SPECIFIC INSTRUCTIONS**

Please read each of the following instructions carefully before attempting questions :

There are **EIGHT** questions divided in **TWO** Sections.

Candidate has to attempt **FIVE** questions in all.

Questions No. 1 and 5 are **compulsory** and out of the remaining, any **THREE** are to be attempted choosing at least **ONE** question from each section.

The number of marks carried by a question/part is indicated against it.

Wherever any assumptions are made for answering a question, they must be clearly indicated.

Diagrams/Figures, wherever required, shall be drawn in the space provided for answering the question itself.

Unless otherwise mentioned, symbols and notations have their usual standard meanings.

Attempts of questions shall be counted in sequential order. Unless struck off, attempt of a question shall be counted even if attempted partly.

Any page or portion of the page left blank in the Question-cum-Answer (QCA) Booklet must be clearly struck off.

Answers must be written in **ENGLISH** only.

## SECTION 'A'

- 1.(a) A steel tube ( $E = 200 \text{ GPa}$ ) with a 32 mm outer diameter and a 4 mm thickness is placed in a vise that is adjusted so that its jaws just touch the ends of the tube without exerting any pressure on them. The two forces as shown in figure are then applied to the tube. After these forces are applied the vise is adjusted to decrease the distance between its jaws by 0.2 mm. Determine

- (i) the forces exerted by the vise on the tube at  $A$  and  $D$
- (ii) the change in length of the portion  $BC$  of the tube

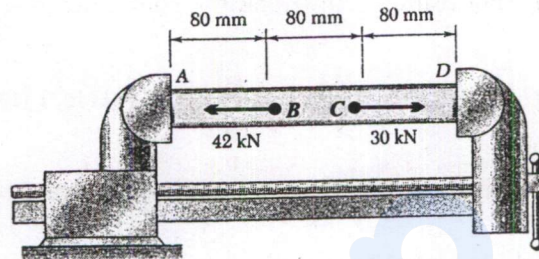

12

- 1.(b) The compound beam shown in figure below is pin connected at  $B$ . Determine the components of reaction at its supports. Neglect its weight and thickness.

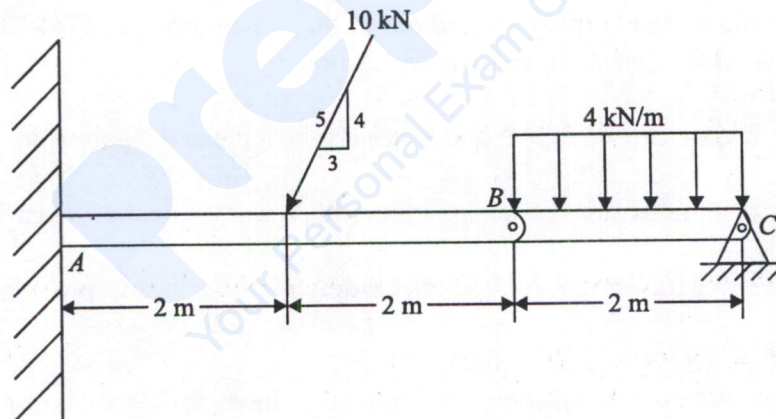

12

- 1.(c) A compound cylinder is formed by shrinking one tube of 100 mm internal diameter and 25 mm wall thickness on to another tube of 100 mm external diameter and 25 mm wall thickness. Both the tubes are made of steel (with  $E = 210 \text{ GPa}$ ) and the shrinkage allowance based on radius is 0.02 mm. Determine the pressure set up at the junction due to shrinkage.

12

- 1.(d) A pair of  $20^\circ$  full depth involute spur gears are in mesh. The larger gear has 48 teeth whereas the pinion has 12 teeth. The module is 10 mm. Determine

- (i) the reduction in addendum of the gear to avoid interference, and
- (ii) Contact ratio

12

- 1.(e) A rotating solid shaft of diameter  $d$  is under bending moment  $M$  and Torque  $T$  without any axial load. Determine the equivalent bending moment,  $M_e$ , using Maximum Normal Stress Theory (MNST) and Distorsion Energy Theory (DE) and the equivalent twisting moment,  $T_e$ , using Maximum Shear Stress Theory (MSST). Effects due to fatigue and stress concentration are to be neglected. 12

- 2.(a) A cart  $A$  shown in figure having a mass of 200 kg is held on an incline so as to just touch the undeformed spring whose constant  $K$  is 50 N/mm. If body  $A$  is released very slowly, what distance down the incline must  $A$  move to reach an equilibrium configuration? If body  $A$  is released suddenly, what is its speed when it reaches the aforementioned equilibrium configuration for a slow release?

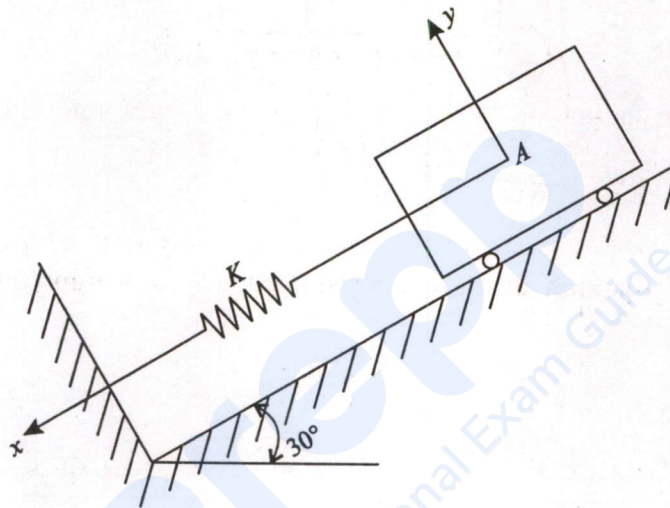

20

- 2.(b) The torque produced by an engine is given by the expression

$$T = (5000 + 1500 \sin 3\theta) \text{ N-m}$$

where  $\theta$  (theta) is the angle turned by the crank measured from some datum. The mean engine speed is 300 rpm and the flywheel and other rotating parts attached to the shaft have a mass of 450 kg with radius of gyration 500 mm. Determine

- (i) the power of the engine
- (ii) percentage fluctuation of speed when the resisting torque is constant
- (iii) percentage fluctuation of speed when the resisting torque is  $(5000 + 600 \sin \theta)$

20

2.(c) The following data refers to a pair of spur gears with  $20^\circ$  full depth involute teeth :

Number of teeth on pinion	=	24
Number of teeth on gear	=	56
Speed of pinion	=	1200 rpm
Module	=	3 mm
Face width	=	30 mm

Both gears are made of steel with an ultimate tensile strength of  $600 \text{ N/mm}^2$ . Using the velocity factor to account for the dynamic load and assuming service factor as 1.5, determine

- beam strength, and
- rated power that the gears can transmit without bending failure, if the factor of safety is 1.5.

Take Lewis form factor for 24 teeth equal to 0.337, and velocity factor,  $C_v = \frac{3}{3+v}$ , where  $v$  is the pitch line velocity in m/s. 20

3.(a) Find the value of  $a$  and draw the bending moment diagram for the beam shown in figure below.

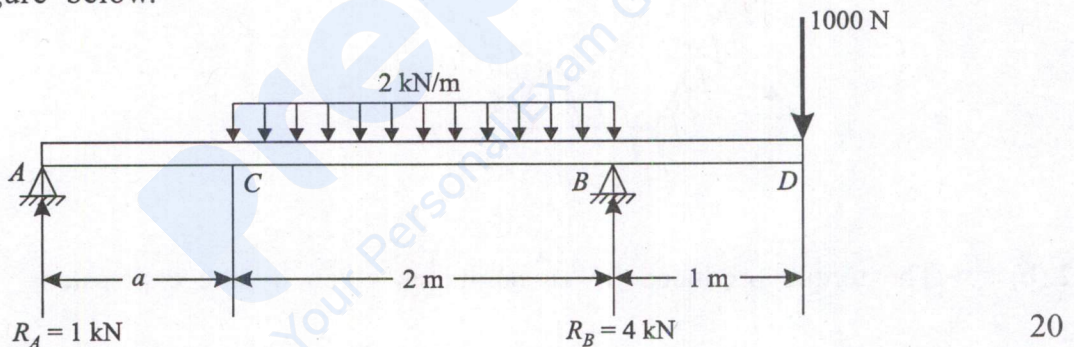

3.(b)(i) A torsional pendulum has a natural frequency of 200 cycles/min when vibrating in a vacuum. The mass moment of inertia of the disc is  $0.2 \text{ kg-m}^2$ . It is then immersed in oil and its natural frequency is found to be 180 cycles/min. Determine the damping constant.

If the disc, when placed in oil, is given an initial angular displacement of  $2^\circ$ , find its displacement at the end of first cycle. 10

3.(b)(ii) The natural frequency of vibration of a person is found to be 5.2 Hz while standing on a horizontal floor. Assuming damping to be negligible, determine

- the equivalent stiffness of his body in the vertical direction if the mass of the person is 70 kg.
- the amplitude of vertical displacement of the person if the floor is subjected to a vertical harmonic vibration of frequency 5.3 Hz and amplitude 0.1 m due to an unbalanced rotating machine operating on the floor. 10

- 3.(c) A welded connection of steel plates as shown in figure is subjected to an eccentric force of 10 kN. Assuming static conditions, determine the throat dimension of the welds if the permissible shear stress is limited to 95 MPa.

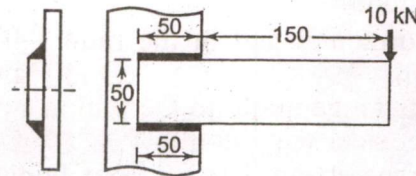

20

- 4.(a) Find the position of the centroid of a *T*-section shown in figure below. The flange is 100×15 mm and the web is 135×15 mm. A cantilever of length 3000 mm and of section shown, with flange at the top, carries a load  $W$  at the free end. What is the maximum value of  $W$ , if the stress in the section is not to exceed 50 N/mm<sup>2</sup>.

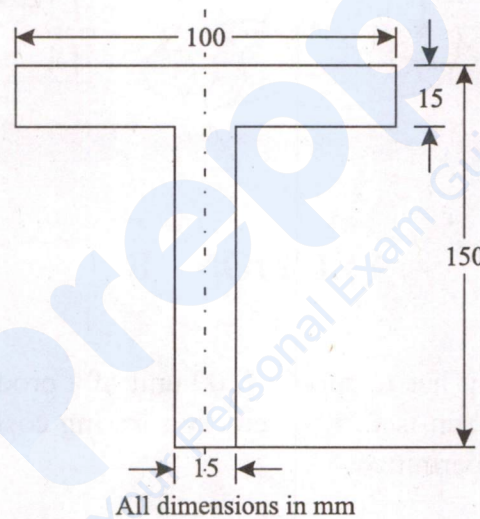

20

- 4.(b)(i) What is the controlling force of a governor? Draw a typical controlling force diagram for spring controlled governors and explain how it helps in establishing the stability or instability of a governor. 8
- 4.(b)(ii) In case of a Porter governor each arm is 250 mm long and the arms are pivoted on the governor axis. The weight of the sleeve is 300 N and the weight of each ball is 50 N. The radii of rotation of the balls corresponding to minimum and maximum speeds are 130 mm and 170 mm respectively. Determine the range of speed of the governor neglecting friction. If the friction at the sleeve is taken equivalent to 25 N of load at the sleeve, determine how the speed range is modified. 12

- 4.(c) The horizontal shaft  $ABCD$  is mounted in bearings at  $B$  and  $D$  as shown in figure. A belt passes around the 250 mm diameter pulley fixed to the shaft at  $A$  and a gear pinion of 150 mm pitch diameter is mounted on the shaft at  $C$ . Shaft diameters and axial disposition of the components are as sketched. The belt strand tensions are horizontal and in the ratio  $\frac{F_1}{F_2} = 4$ , while the vertical reaction on the pinion,  $P$ , acts tangentially to the pinion's pitch circle. Ascertain the shaft's safety factor when transferring 20 kW from belt to pinion at a steady 450 rpm, taking the yield strength of the ductile shaft material to be 500 MPa. Fatigue and stress concentrations are to be neglected. All dimensions are in mm. Use Maximum Shear Stress Theory.

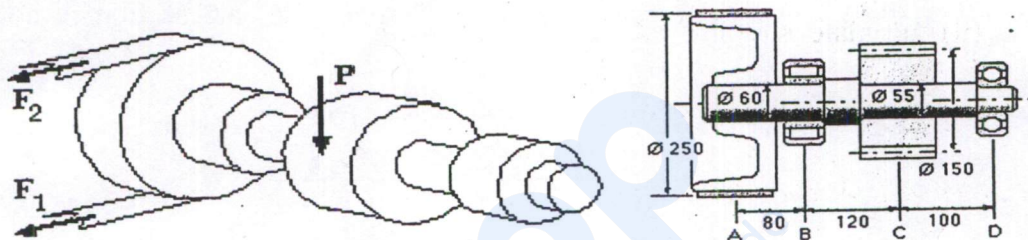

20

### SECTION 'B'

- 5.(a) A manufacturing unit has to supply 4200 unit of a product per year to the customer. The set-up cost per run is ₹75. Inventory carrying cost is ₹1.5 per unit per annum. Shortages are not permitted.

Determine the following :

- (i) Economic order quantity
- (ii) Optimum number of order per annum
- (iii) Average annual inventory cost (minimum)
- (iv) Optimum period of supply per optimum order

12

5.(b) A round specimen of wrought iron of diameter 12.5 mm and gauge length of 100 mm was tested in tension upto fracture. Following observations were obtained :

Load upto yield point	= 29.5 kN
Maximum load	= 44 kN
Load at time of fracture	= 37 kN
Diameter at neck	= 9.2 mm
Total extention of specimen	= 28.5 mm

Calculate

- (i) yield strength
- (ii) ultimate strength
- (iii) actual breaking stress
- (iv) percentage elongation
- (v) modulus of resilience at yield point stress

Take Young's modulus  $E = 200 \text{ kN/mm}^2$

2×4+4=12

5.(c) Two systems are represented by its system matrix as given below. Determine the characteristic equation, its roots and establish the stability of each of the system.

$$(i) A = \begin{bmatrix} -1 & 0 & 0 \\ 0 & -2 & 0 \\ 0 & 0 & -3 \end{bmatrix} \quad (ii) \begin{bmatrix} 0 & 1 & 0 \\ 0 & 0 & 1 \\ 1 & -3 & 3 \end{bmatrix}$$

6×2=12

5.(d) A machine component performs a harmonic motion and a vibrometer having a natural frequency of 5 rad/sec and damping ratio = 0.3 is attached to this machine component. If the difference between the maximum and the minimum recorded values is 6 mm, find the amplitude of motion of the vibrating component, when its frequency is 30 rad/sec.

12

5.(e) Determine the inverse of the following transformation matrix :

$$T = \begin{bmatrix} 0.527 & -0.574 & 0.628 & 2 \\ 0.369 & 0.819 & 0.439 & 5 \\ -0.766 & 0 & 0.643 & 3 \\ 0 & 0 & 0 & 1 \end{bmatrix}$$

12

- 6.(a) In an organisation, manufacturing of a component is composed of 7 activities whose time estimates are listed in the table below. Activities are identified by their beginning (*i*) and ending (*j*) node numbers.

Activity ( <i>i</i> - <i>j</i> )	Estimated duration (weeks)		
	Optimistic	Most likely	Pessimistic
1 - 2	2	2	8
1 - 3	2	5	8
1 - 4	3	3	9
2 - 5	2	2	2
3 - 5	3	6	15
4 - 6	3	6	9
5 - 6	4	7	16

- (i) Draw the network diagram of activities.
- (ii) Find the expected duration and variance for each activity. What is the expected project length.
- (iii) Determine the critical path.
- (iv) Calculate the variance and standard deviation of the project length.
- (v) The earliest and latest expected completion time of each event.  $4 \times 5 = 20$

- 6.(b) In a machining operation, under orthogonal cutting condition with a cutting tool of rake angle  $12^\circ$ , the following data were observed :

Vertical component of cutting force	= 1600 N
Horizontal component of cutting force	= 1250 N
Chip thickness ratio	= 0.25
Cutting speed	= 200 m/min

Calculate the following :

- (i) Friction force along the rake face
- (ii) Normal force on the rake face
- (iii) Resultant cutting force
- (iv) Shear force along the shear plane
- (v) Normal force on the shear plane
- (vi) Work done in shear
- (vii) Work done in friction

$$3 \times 6 + 2 = 20$$

6.(c) Generate the forward kinematic model of the 3 DOF (RRP) Spherical Manipulator Arm, shown in the figure, by

- (i) generating and drawing the frames using DH rules
- (ii) generating the DH parameters table from the assigned frame
- (iii) generating the individual transformation matrices,  ${}^0T_1$ ,  ${}^1T_2$  and  ${}^2T_3$
- (iv) generating the overall transformation matrix  ${}^0T_3$

Note :  $\{0\}$ <sup>th</sup> frame will be at the base of the manipulator.

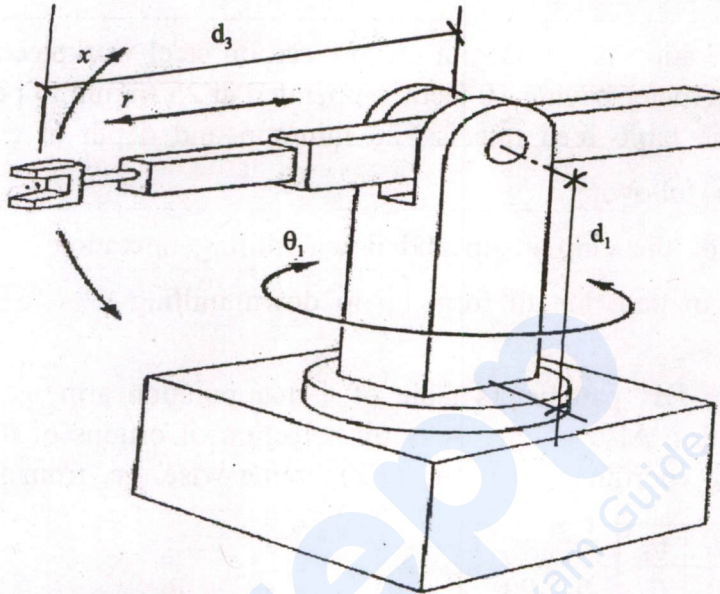

The homogeneous transformation matrix  ${}^{i-1}T_i$  is given as

$${}^{i-1}T_i = \begin{bmatrix} C\theta_i & -S\theta_i C\alpha_i & S\theta_i S\alpha_i & a_i C\theta_i \\ S\theta_i & C\theta_i C\alpha_i & -C\theta_i S\alpha_i & a_i S\theta_i \\ 0 & S\alpha_i & C\alpha_i & d_i \\ 0 & 0 & 0 & 1 \end{bmatrix} \quad 5 \times 4 = 20$$

7.(a) Explain the meaning of Miller indices in a unit crystal cell. Determine the Miller indices of directions  $A$ ,  $B$  and  $C$  in figure below.

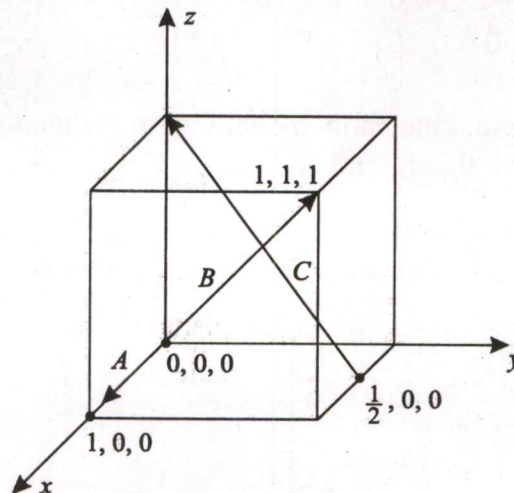

- 7.(b)(i) A shaper machine is used to machine a medium carbon steel workpiece of 225 mm in length and 125 mm in width. The shaper machine is operated at 125 cutting strokes per minute, feed of 0.5 mm per stroke and a depth of cut of 5 mm. The forward stroke is completed in  $220^\circ$ .

Calculate the percentage of time when the tool is not contacting the workpiece also calculate the total machining time for machining the component.

Assume that approach distance = 30 mm.

10

- 7.(b)(ii) A milling operation is carried out on low carbon steel workpiece. A milling cutter of 125 mm diameter having 10 teeth is operated at 25 m/min to perform the milling operation. The table feed rate is 120 mm/min and depth of cut is 5 mm.

Calculate the following :

(A) Length of the chip in up and down milling operation

(B) Change in path length from up to down milling

10

- 7.(c)(i) For the given DH parameters table of a manipulation arm; generate the frames as per DH rules. Also give reasons for selection of origins of the frames and the corresponding coordinate axes (X, Y, Z), frame wise, i.e. from frame {0} to {3}.

	$d_i$	$\theta_i$	$a_i$	$\alpha_i$
${}^0T_1$	0	$\theta_1$	0	$90^\circ$
${}^1T_2$	0	$\theta_2$	$L_2$	0
${}^2T_3$	0	$\theta_3$	$L_3$	0

10

- 7.(c)(ii) The overall transformation matrix of a 3 DOF manipulator arm is given below :

$${}^0T_3 = \begin{bmatrix} \cos\theta_1 & 0 & -\sin\theta_1 & -d_3 \sin\theta_1 \\ \sin\theta_1 & 0 & \cos\theta_1 & d_3 \cos\theta_1 \\ 0 & -1 & 0 & d_2 \\ 0 & 0 & 0 & 1 \end{bmatrix}$$

(A) Use inverse kinematic modelling to generate the expressions for the joint parameters  $\theta_1$ ,  $d_2$  and  $d_3$ .

(B) Determine all possible values of  $\theta_1$ ,  $d_2$  and  $d_3$  for the above manipulator from the following overall transformation matrix

$$\begin{bmatrix} 0.866 & 0 & -0.5 & -5 \\ 0.5 & 0 & 0.866 & 8.66 \\ 0 & -1 & 0 & 15 \\ 0 & 0 & 0 & 1 \end{bmatrix}$$

5×2=10

- 8.(a)(i) Explain the 'laws of corrosion'. Give examples of two metals following the law in each case. Oxidation loss on copper surface is 0.05 mm in 15 hours. How much will be the loss in 225 hours? 10
- 8.(a)(ii) What are the different 'top-down' and 'bottom-up' methods for the synthesis of nano structured materials. With a sketch briefly explain the mechanical high energy ball milling for the synthesis of nano materials. 10
- 8.(b) Calculate the power required to draw hot-drawn steel wire from 15 mm to 12.5 mm in diameter at 120 m/min. The coefficient of friction between the die and wire is 0.15 and die angle is  $5^\circ$ . Average flow stress for hot-drawn steel is  $30 \text{ kgf/mm}^2$ . Also calculate the maximum reduction possible. Assume that back pull = 0. 20
- 8.(c) A 3 element rectangular rosette is used at a certain point on a steel machine part as shown in the figure. Determine the principal strains and principal stresses using analytical expressions, if the measured strains are  $\epsilon_0 = -220 \mu\text{m/m}$ ,  $\epsilon_{45^\circ} = 120 \mu\text{m/m}$  and  $\epsilon_{90^\circ} = 220 \mu\text{m/m}$  assuming  $E = 200 \text{ GPa}$  and  $\nu = 0.3$ .

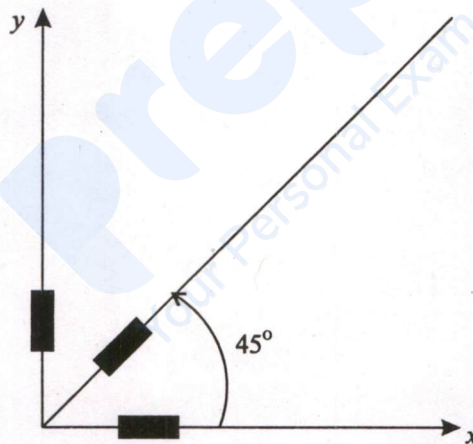

20

**prepp**  
Your Personal Exam Guide