

## NEET (UG)-2024 Q4 Question Paper

<b>Time Allowed</b> :3 hours 20 minutes	<b>Maximum Marks</b> :720	<b>Total Questions</b> :200
---	---------------------------	-----------------------------

### General Instructions

**Read the following instructions very carefully and strictly follow them:**

1. The test is of 3 hours 20 minutes duration, and the Test Booklet contains 200 multiple-choice questions (four options with a single correct answer) from Physics, Chemistry, and Biology (Botany and Zoology). The questions in each subject are divided into two Sections (A and B):
2. Section-A shall consist of 35 questions in each subject (Questions Nos-1 to 35, 51 to 85, 101 to 135, and 151 to 185). All questions are compulsory.
3. Section-B shall consist of 15 questions in each subject (Questions Nos-36 to 50, 86 to 100, 136 to 150, and 186 to 200). In Section B, a candidate needs to attempt any 10 questions out of 15 in each subject.
4. Each question carries 4 marks. For each correct response, the candidate will get 4 marks. For each incorrect response, 1 mark will be deducted from the total score. The maximum marks are 720.
5. Use a Blue/Black Ball Point Pen only for writing particulars on this page/markings responses on the Answer Sheet.
6. Rough work is to be done in the space provided for this purpose in the Test Booklet only.
7. On completion of the test, the candidate must hand over the Answer Sheet (ORIGINAL and OFFICE copy) to the Invigilator before leaving the Room/Hall. The candidates are allowed to take away this Test Booklet with them.

## Physics

### Section A

1. A thin spherical shell is charged by some source. The potential difference between the two points  $C$  and  $P$  (in V) shown in the figure is: (Take  $\frac{1}{4\pi\epsilon_0} = 9 \times 10^9$  SI units)

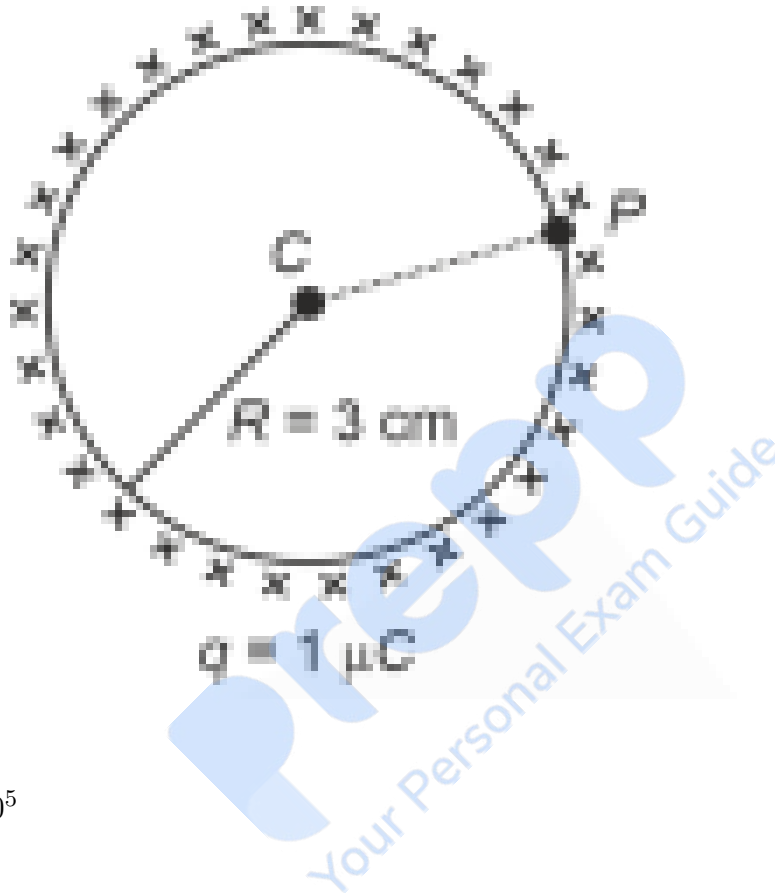

- (1)  $3 \times 10^5$
- (2)  $1 \times 10^5$
- (3)  $0.5 \times 10^5$
- (4) Zero

---

2. The output  $Y$  of the given logic gate is similar to the output of a/an:

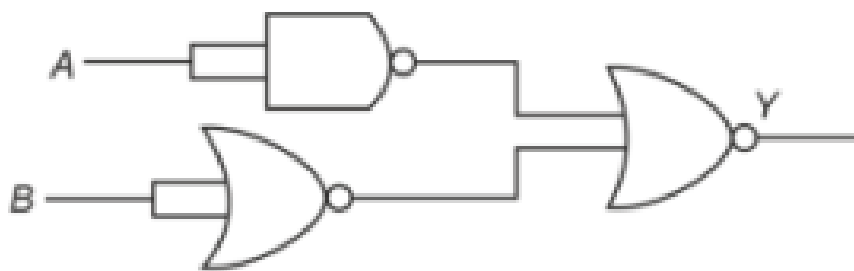

- (1) NAND gate  
 (2) NOR gate  
 (3) OR gate  
 (4) AND gate

**3. If the monochromatic source in Young's double-slit experiment is replaced by white light, then:**

- (1) Interference pattern will disappear  
 (2) There will be a central dark fringe surrounded by a few colored fringes  
 (3) There will be a central bright white fringe surrounded by a few colored fringes  
 (4) All bright fringes will be of equal width

**4. In a vernier caliper,  $(N + 1)$  divisions of the vernier scale coincide with  $N$  divisions of the main scale. If 1 MSD represents 0.1 mm, the vernier constant (in cm) is:**

- (1)  $\frac{1}{10N}$   
 (2)  $\frac{1}{100(N+1)}$   
 (3)  $100N$   
 (4)  $10(N + 1)$

**5. The maximum elongation of a steel wire of 1 m length if the elastic limit of steel and its Young's modulus, respectively, are  $8 \times 10^8 \text{ N/m}^2$  and  $2 \times 10^{11} \text{ N/m}^2$ , is:**

- (1) 4 mm

- (2) 0.4 mm
  - (3) 40 mm
  - (4) 8 mm
- 

**6. The moment of inertia of a thin rod about an axis passing through its mid point and perpendicular to the rod is  $2400 \text{ g cm}^2$ . The length of the 400 g rod is nearly:**

- (1) 8.5 cm
  - (2) 17.5 cm
  - (3) 20.7 cm
  - (4) 72.0 cm
- 

**7. A tightly wound 100-turn coil of radius 10 cm carries a current of 7 A. The magnetic field at the center of the coil is:**

(Take permeability of free space as  $4\pi * 10^{-7}$  SI units)

- (1) 44 mT
  - (2) 4.4 T
  - (3) 4.4 mT
  - (4) 44 T
- 

**8. At any instant of time  $t$ , the displacement of any particle is given by  $2t^{-1}$  (SI unit) under the influence of force of 5 N. The value of instantaneous power is (in SI unit):**

- (1) 10
  - (2) 5
  - (3) 7
  - (4) 6
- 

**9. Two bodies A and B of same mass undergo completely inelastic one dimensional**

**collision. The body A moves with velocity  $v_1$  while body B is at rest before collision. The velocity of the system after collision is  $v_2$ . The ratio  $v_1 : v_2$  is**

- (1) 1 : 2
  - (2) 2 : 1
  - (3) 4 : 1
  - (4) 1 : 4
- 

**10. A horizontal force 10 N is applied to a block A as shown in figure. The mass of blocks A and B are 2 kg and 3 kg respectively. The blocks slide over a frictionless surface. The force exerted by block A on block B is :**

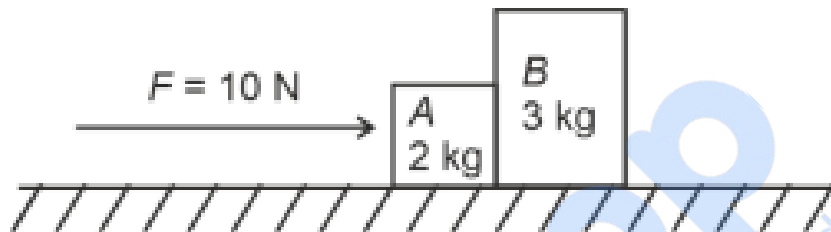

- (1) 0
  - (2) 4 N
  - (3) 6 N
  - (4) 10 N
- 

**11. The mass of a planet is  $\frac{1}{10}$  that of the earth and its radius is  $\frac{1}{2}$  that of the earth. The acceleration due to gravity on the planet is:**

- (1)  $19.6\text{ m/s}^2$
  - (2)  $9.8\text{ m/s}^2$
  - (3)  $4.9\text{ m/s}^2$
  - (4)  $3.92\text{ m/s}^2$
- 

**12. Consider the following statements A and B and choose the correct option:**

- **A:** For a solar-cell, the I-V characteristics lies in the IV quadrant of the given graph.
- **B:** In a reverse biased pn junction diode, the current measured in  $\mu A$ , is due to majority charge carriers.

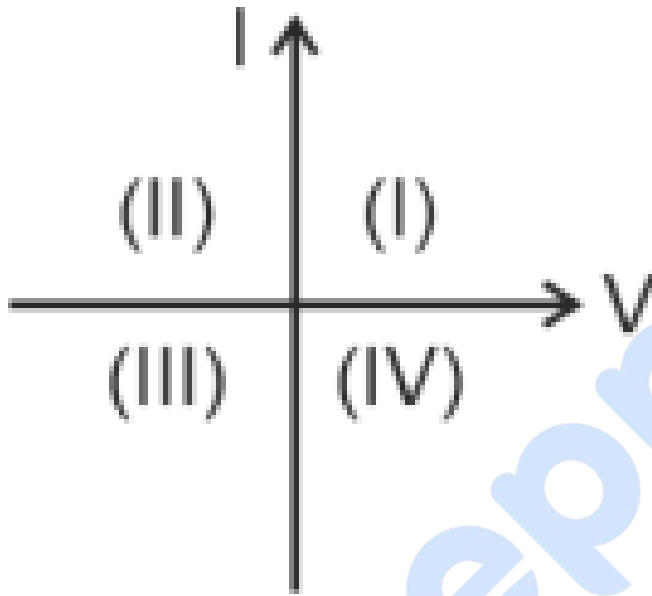

- (1) A is correct but B is incorrect.
- (2) A is incorrect but B is correct.
- (3) Both A and B are correct.
- (4) Both A and B are incorrect.

---

**13. A light ray enters through a right angled prism at point P with the angle of incidence 30 degree as shown in figure. It travels through the prism parallel to its base BC and emerges along the face AC. The refractive index of the prism is:**

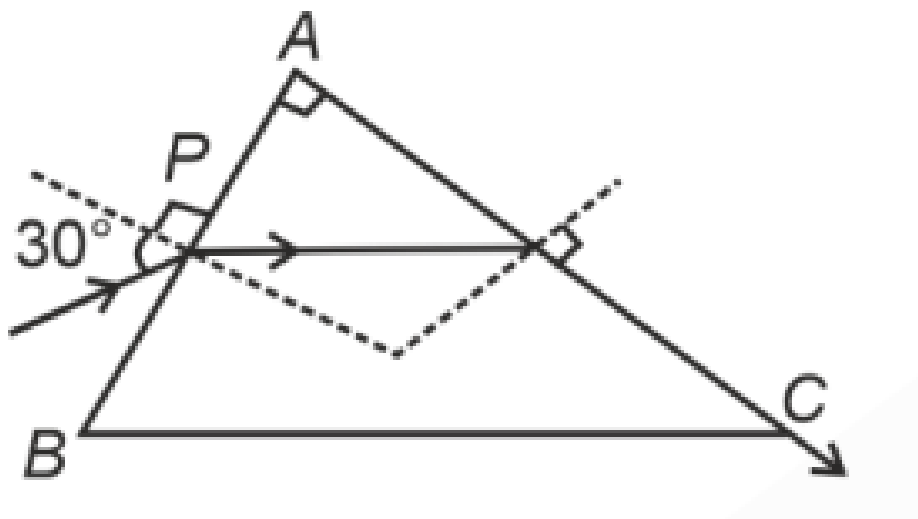

- (1)  $\frac{\sqrt{5}}{4}$
- (2)  $\frac{\sqrt{5}}{2}$
- (3)  $\frac{\sqrt{3}}{4}$
- (4)  $\frac{\sqrt{3}}{2}$

**14. Given below are two statements:**

**Statement I:** Atoms are electrically neutral as they contain an equal number of positive and negative charges.

**Statement II:** Atoms of each element are stable and emit their characteristic spectrum.

In the light of the above statements, choose the **most appropriate** answer from the options given below.

- (1) Both Statement I and Statement II are correct
- (2) Both Statement I and Statement II are incorrect
- (3) Statement I is correct but Statement II is incorrect
- (4) Statement I is incorrect but Statement II is correct

**15. A thin flat circular disc of radius 4.5 cm is placed gently over the surface of water. If surface tension of water is  $0.07 \text{ N m}^{-1}$ , then the excess force required to take it away from the surface is**

- (1) 19.8 mN
- (2) 198 N
- (3) 1.98 mN
- (4) 99 N

**16. In the given diagram, a strong bar magnet is moved through a loop. The direction of induced current is:**

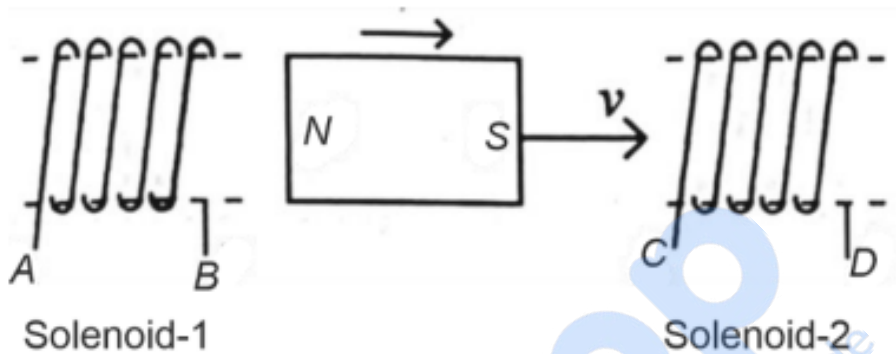

- (1) AB and DC
- (2) BA and CD
- (3) AB and CD
- (4) BA and DC

**17. A particle moving with uniform speed in a circular path has:**

- (1) Constant velocity
- (2) Constant acceleration
- (3) Constant velocity but varying acceleration
- (4) Varying velocity and varying acceleration

**18. Match List I with List II.**

<b>List I</b> (Spectral Lines of Hydrogen for transitions from)	<b>List II</b> (Wavelengths (nm))
A. $n_2 = 3$ to $n_1 = 2$	I. 410.2
B. $n_2 = 4$ to $n_1 = 2$	II. 434.1
C. $n_2 = 5$ to $n_1 = 2$	III. 656.3
D. $n_2 = 6$ to $n_1 = 2$	IV. 486.1

- (1) A-II, B-I, C-IV, D-III  
 (2) A-III, B-IV, C-II, D-I  
 (3) A-IV, B-III, C-I, D-II  
 (4) A-I, B-II, C-III, D-IV

**19. The quantities which have the same dimensions as those of solid angle are:**

- (1) Strain and angle  
 (2) Stress and angle  
 (3) Strain and arc  
 (4) Angular speed and stress

**20. An unpolarized light beam strikes a glass surface at Brewster's angle. Then**

- (1) The reflected light will be partially polarized.  
 (2) The refracted light will be completely polarized.  
 (3) Both the reflected and refracted light will be partially polarized.  
 (4) The reflected light will be completely polarized.

**21. Given below are two statements: one is labelled as Assertion A and the other is labelled as Reason R.**

**Assertion A:** The potential (V) at any axial point, at 2 m distance (r) from the centre of the dipole of dipole moment vector  $\vec{P}$  of magnitude,  $4 \times 10^{-6}$  C m, is  $\pm 9 \times 10^3$  V.

(Take  $\frac{1}{4\pi\epsilon_0} = 9 \times 10^9$  SI units)

**Reason R:**  $V = \pm \frac{2P}{4\pi\epsilon_0 r^2}$ , where  $r$  is the distance of any axial point, situated at 2 m from the centre of the dipole.

In the light of the above statements, choose the correct answer from the options given below:

- (1) Both A and R are true and R is the correct explanation of A.
- (2) Both A and R are true and R is NOT the correct explanation of A.
- (3) A is true but R is false.
- (4) A is false but R is true.

**22. A wheel of a bullock cart is rolling on a level road as shown in the figure below. If its linear speed is  $v$  in the direction shown, which one of the following options is correct (P and Q are any highest and lowest points on the wheel, respectively)?**

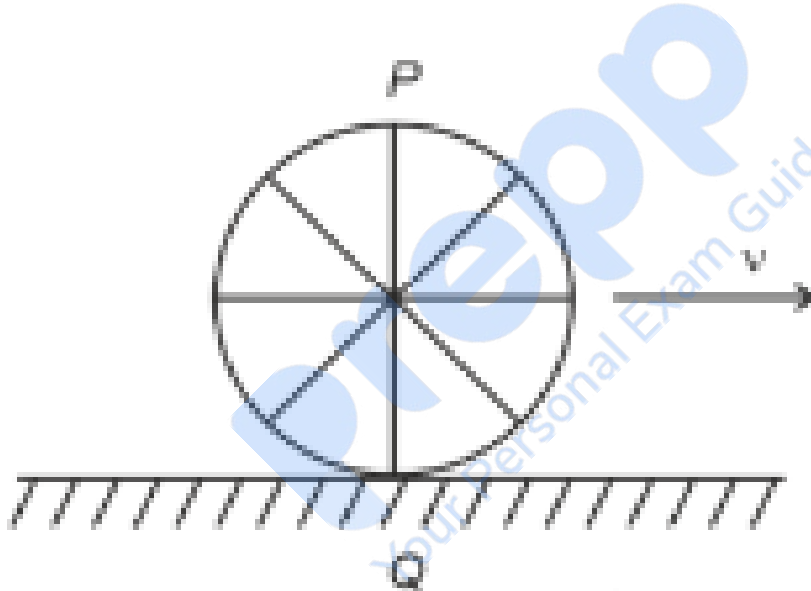

- (A) Point  $P$  moves faster than point  $Q$
- (B) Both the points  $P$  and  $Q$  move with equal speed
- (C) Point  $P$  has zero speed
- (D) Point  $P$  moves slower than point  $Q$

**23. If  $x = 5 \sin(\pi t + \frac{\pi}{3})$  represents the motion of a particle, find the amplitude and time period of the motion.**

- (1) 5 cm, 2 s
- (2) 5 m, 2 s
- (3) 5 cm, 1 s
- (4) 5 m, 1 s

---

24. A logic circuit provides the output  $Y$  as per the truth table given below. Identify the circuit.

Input $A$	Input $B$	Output $Y$
0	0	0
0	1	1
1	0	1
1	1	0

- (A)  $A\bar{B} + \bar{A}$
- (B)  $A\bar{B} + \bar{A}$
- (C)  $\bar{B}$
- (D)  $B$

---

25. If  $c$  is the velocity of light in free space, the correct statements about photons are:

- A:** The energy of a photon is  $E = h\nu$ .
- B:** The velocity of a photon is  $c$ .
- C:** The momentum of a photon,  $p = \frac{h\nu}{c}$ .
- D:** In a photon-electron collision, both total energy and total momentum are conserved.
- E:** Photon possesses positive charge.

- (A) A and B only
  - (B) A, B, C and D only
  - (C) A, C and D only
  - (D) A, B, D and E only
- 

26. A bob is whirled in a horizontal plane by means of a string with an initial speed of  $\omega$  rpm. The tension in the string is  $T$ . If speed becomes  $2\omega$  while keeping the same radius, the tension in the string becomes:

- (1)  $T$
  - (2)  $4T$
  - (3)  $\frac{T}{4}$
  - (4)  $\sqrt{2}T$
- 

27. The terminal voltage of the battery, whose emf is 10 V and internal resistance  $1\ \Omega$ , when connected through an external resistance of  $4\ \Omega$  as shown in the figure is:

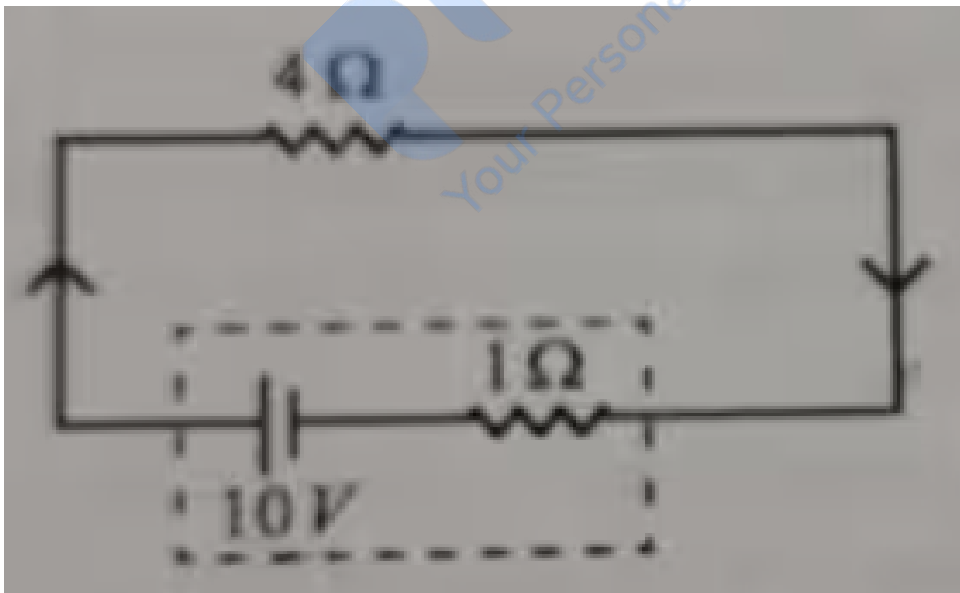

- (1) 4V

- (2) 6 V
- (3) 8 V
- (4) 10 V

**28. In a uniform magnetic field of  $0.049\text{ T}$ , a magnetic dipole is placed with a dipole moment of  $5\text{ A}\cdot\text{m}^2$ . Calculate the torque acting on it if the angle between the dipole moment and magnetic field is  $30^\circ$ .**

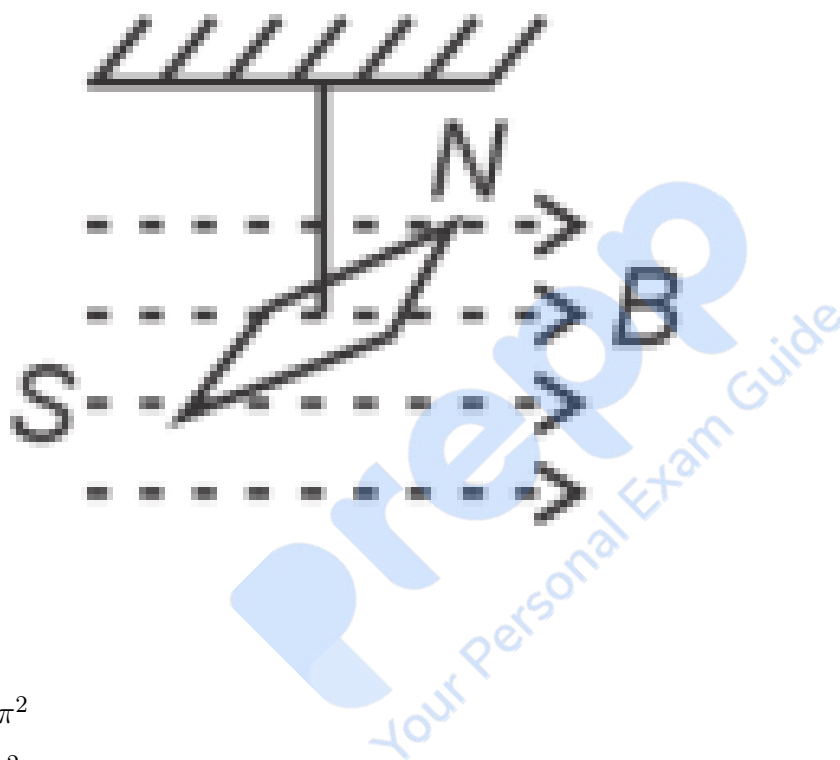

- (1)  $5\pi^2$
- (2)  $128\pi^2$
- (3)  $50\pi^2$
- (4)  $1280\pi^2$

**29. A wire of length  $l$  and resistance  $100\ \Omega$  is divided into 10 equal parts. The first 5 parts are connected in series while the next 5 parts are connected in parallel. The two combinations are again connected in series. The resistance of this final combination is:**

- (1)  $26\ \Omega$
- (2)  $52\ \Omega$

(3)  $55 \Omega$ (4)  $60 \Omega$ 

30. Match List-I with List-II:

List-I (Material)	List-II (Susceptibility $\chi$ )
A. Diamagnetic	$\chi = 0$
B. Ferromagnetic	$\chi \ll 1$
C. Paramagnetic	$0 < \chi \ll 1$
D. Non-magnetic	$0 < \chi < \epsilon$

(1) A-II, B-III, C-IV, D-I

(2) A-II, B-I, C-III, D-IV

(3) A-III, B-II, C-I, D-IV

(4) A-IV, B-III, C-II, D-I

31. In the nuclear emission stated above, the mass number and atomic number of the resulting nucleus will be:

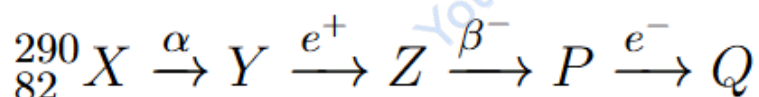

(1) 280, 81

(2) 286, 80

(3) 288, 82

(4) 286, 81

32. The graph which shows the variation of  $\frac{1}{\lambda^2}$  with stopping potential  $V$  for a photoelectric experiment is:

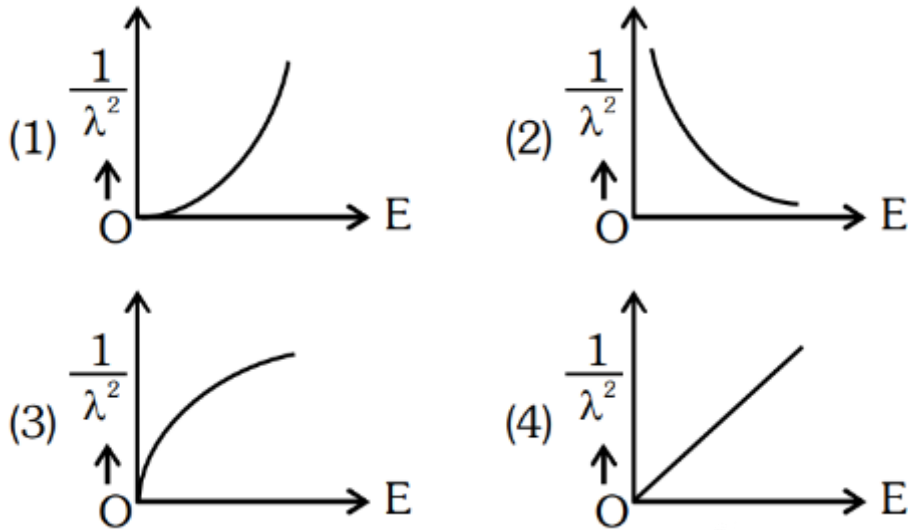

33. In an ideal transformer, the turns ratio is  $\frac{N_p}{N_s} = \frac{1}{2}$ . The ratio  $V_s : V_p$  is equal to (the symbols carry their usual meaning) :

- (1) 1 : 2
- (2) 2 : 1
- (3) 1 : 1
- (4) 1 : 4

34. A thermodynamic system is taken through the cycle  $abcd$ , where  $ab$  is isochoric,  $bc$  is isobaric,  $cd$  is isothermal, and  $da$  is adiabatic. What is the work done during the complete cycle?

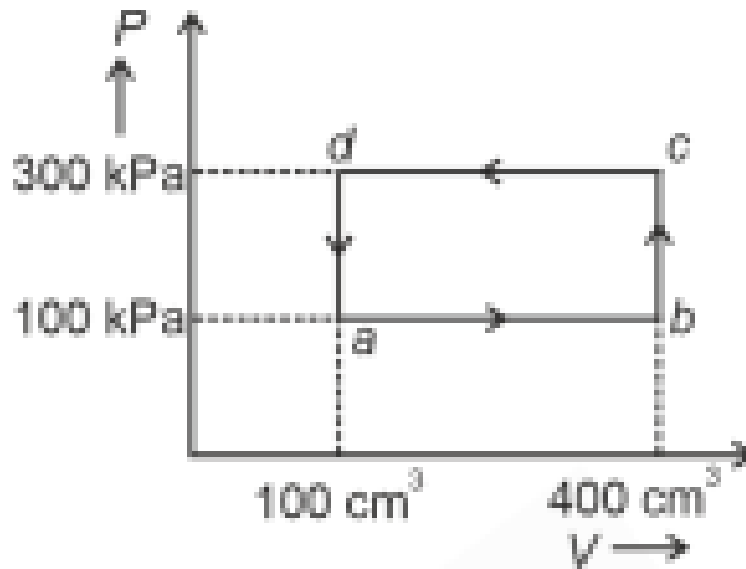

- (1) Zero  
 (2) 30 J  
 (3) -90 J  
 (4) -60 J

35. In the following circuit, the equivalent capacitance between points  $A$  and  $B$  is:

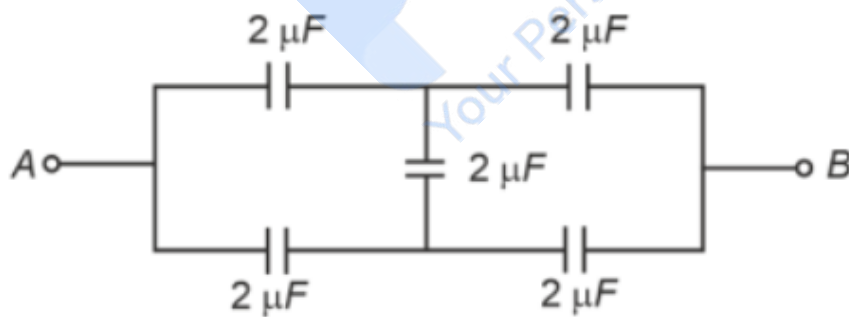

- (1)  $2 \mu\text{F}$   
 (2)  $1 \mu\text{F}$   
 (3)  $0.5 \mu\text{F}$   
 (4)  $4 \mu\text{F}$

---

**36. If the plates of a parallel plate capacitor connected to a battery are moved close to each other, the**

- A. the charge stored in it, increases.**
- B. the energy stored in it, decreases.**
- C. its capacitance increases.**
- D. the ratio of charge to its potential remains the same.**
- E. the product of charge and voltage increases.**

**Choose the most appropriate answer from the options given below:**

- (1) A, B and E only
- (2) A, C and E only
- (3) B, D and E only
- (4) A, B and C only

---

**37. A  $10\ \mu\text{F}$  capacitor is connected to a 210 V, 50 Hz AC supply. What is the peak current in the circuit?**

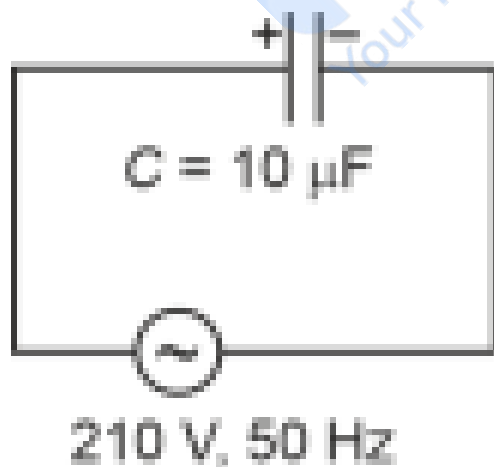

- (1) 0.58 A

- (2) 0.93 A  
 (3) 1.20 A  
 (4) 0.35 A

38. A force defined by  $F = \alpha t^2 + \beta t$  acts on a particle. What is the dimension of the ratio  $\frac{\alpha t}{\beta}$ ?

- (1)  $\frac{\beta}{\alpha}$   
 (2)  $\frac{\alpha t}{\beta}$   
 (3)  $\alpha\beta t$   
 (4)  $\frac{\alpha\beta}{t}$

39. The following graph represents the  $T - V$  curves of a thermodynamic process for three different pressures  $P_1, P_2, P_3$ . Arrange the pressures in increasing order.

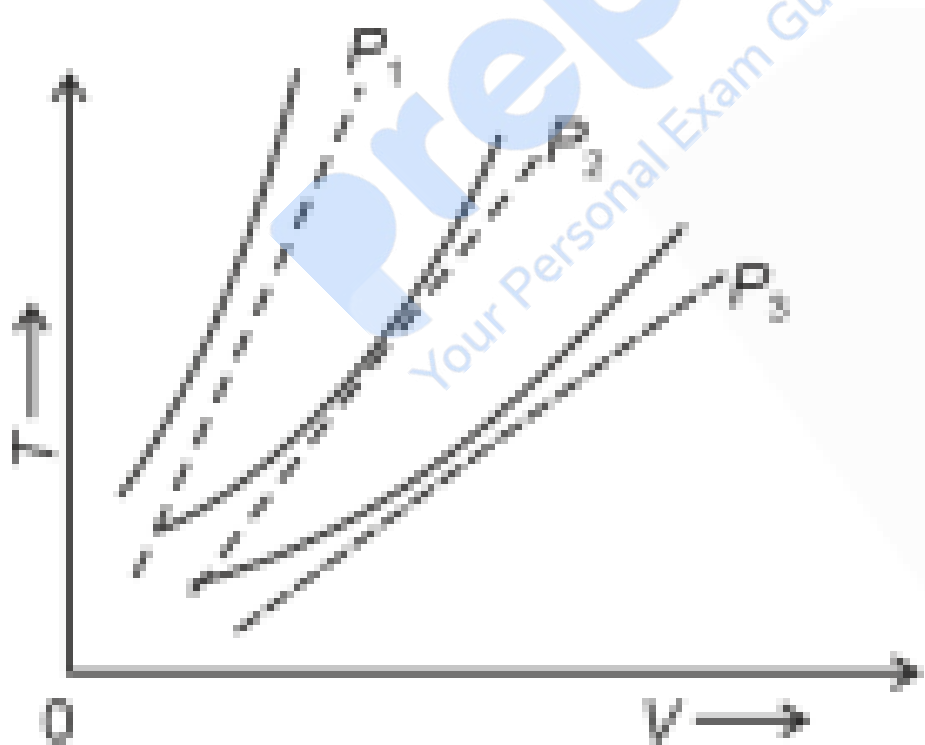

- (1)  $P_3 > P_2 > P_1$

- (2)  $P_1 > P_3 > P_2$
  - (3)  $P_2 > P_1 > P_3$
  - (4)  $P_1 > P_2 > P_3$
- 

**40. An iron bar of length  $L$  has magnetic moment  $M$ . It is bent at the middle of its length such that the two arms make an angle  $60^\circ$  with each other. The magnetic moment of this new magnet is :**

- (1)  $M$
  - (2)  $\frac{M}{2}$
  - (3)  $2M$
  - (4)  $\frac{M}{\sqrt{3}}$
- 

**41. A parallel plate capacitor is charged by connecting it to a battery through a resistor. If  $I$  is the current in the circuit, then in the gap between the plates:**

- (1) There is no current
  - (2) Displacement current of magnitude equal to  $I$  flows in the same direction as  $I$
  - (3) Displacement current of magnitude equal to  $I$  flows in a direction opposite to that of  $I$
  - (4) Displacement current of magnitude greater than  $I$  flows but can be in any direction
- 

**42. A metallic bar of Young's modulus,  $0.5 \times 10^{11} \text{ N/m}^2$ , and coefficient of linear thermal expansion  $10^{-5} \text{ }^\circ\text{C}^{-1}$ , length 1 m and area of cross-section  $10^{-3} \text{ m}^2$ , is heated from  $0 \text{ }^\circ\text{C}$  to  $100 \text{ }^\circ\text{C}$  without expansion or bending. The compressive force developed in it is:**

- (1)  $5 \times 10^3 \text{ N}$
  - (2)  $50 \times 10^3 \text{ N}$
  - (3)  $100 \times 10^3 \text{ N}$
  - (4)  $2 \times 10^3 \text{ N}$
-

**Prepp**  
Your Personal Exam Guide

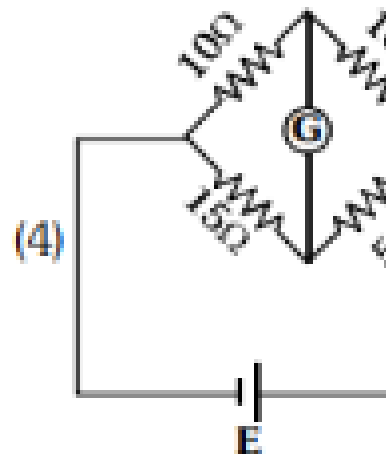
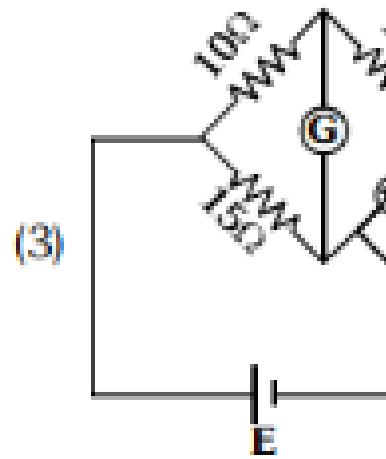
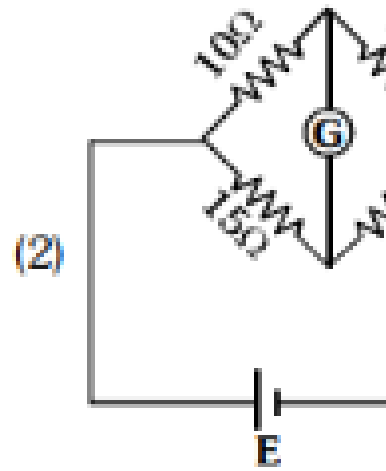
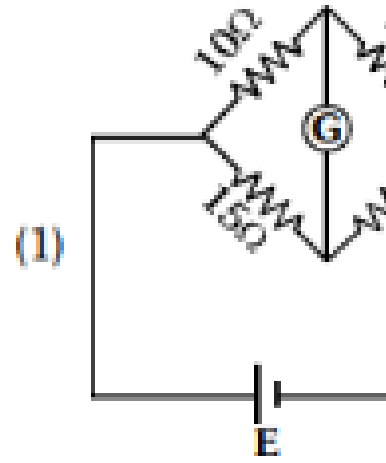



44. The velocity  $v$  – time  $t$  plot of the motion of a body is shown below:

The acceleration  $a$  – time  $t$  graph that best suits this motion is:

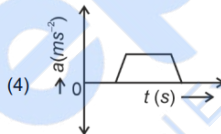
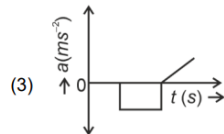
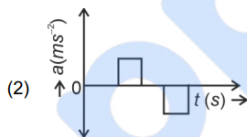
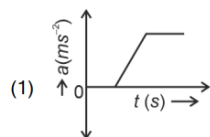

45. A small telescope has an objective of focal length 140 cm and an eye piece of focal length 5.0 cm. The magnifying power of the telescope for viewing a distant object is:

- (1) 34
- (2) 28
- (3) 17
- (4) 32

46. The minimum energy required to launch a satellite of mass  $m$  from the surface of Earth of mass  $M$  and radius  $R$  in a circular orbit at an altitude of  $2R$  from the surface of the Earth is:

- (1)  $\frac{5GmM}{6R}$

- (2)  $\frac{2GmM}{3R}$   
(3)  $\frac{GmM}{2R}$   
(4)  $\frac{GmM}{3R}$
- 

**47. If the mass of the bob in a simple pendulum is increased to thrice its original mass and its length is made half its original length, then the new time period of oscillation is  $\frac{x}{2}$  times its original time period. Then the value of  $x$  is:**

- (1)  $\sqrt{3}$   
(2)  $\sqrt{2}$   
(3)  $2\sqrt{3}$   
(4) 4
- 

**48. A sheet is placed on a horizontal surface in front of a strong magnetic pole. A force is needed to:**

- (A) Hold the sheet there if it is magnetic.  
(B) Hold the sheet there if it is non-magnetic.  
(C) Move the sheet away from the pole with uniform velocity if it is conducting.  
(D) Move the sheet away from the pole with uniform velocity if it is both, non-conducting and non-polar.

Choose the correct statement(s) from the options given below:

- (1) B and D only  
(2) A and C only  
(3) A, C and D only  
(4) C only
- 

**49. Two heaters A and B have power ratings of 1 kW and 2 kW, respectively. Those two are first connected in series and then in parallel to a fixed power source. The ratio of power outputs for these two cases is:**

- (1) 1 : 1  
 (2) 2 : 9  
 (3) 1 : 2  
 (4) 2 : 3

**50. The property which is not of an electromagnetic wave travelling in free space is that:**

- (1) They are transverse in nature  
 (2) The energy density in electric field is equal to energy density in magnetic field  
 (3) They travel with a speed equal to  $\frac{1}{\sqrt{\mu_0\epsilon_0}}$   
 (4) They originate from charges moving with uniform speed

**51. Among Group 16 elements, which one does NOT show -2 oxidation state?**

- (1) O  
 (2) Se  
 (3) Te  
 (4) Po

**52. Match List I with List II.**

List I (Molecule)	List II (Number and types of bonds)
A. Ethane	I. One $\sigma$ -bond and two $\pi$ -bonds
B. Ethene	II. Two $\pi$ -bonds
C. Carbon molecule, $C_2$	III. One $\sigma$ -bond
D. Ethyne	IV. One $\sigma$ -bond and one $\pi$ -bond

(1) A-I, B-IV, C-II,

D-III

- (2) A-IV, B-III, C-I, D-I  
 (3) A-III, B-IV, C-II, D-I  
 (4) A-III, B-IV, C-I, D-II

---

**53. Fehling's solution 'A' is:**

- (1) aqueous copper sulphate
  - (2) alkaline copper sulphate
  - (3) alkaline solution of sodium potassium tartrate (Rochelle's salt)
  - (4) aqueous sodium citrate
- 

**54. Match List I with List II.**

List I (Conversion)	List II (Faraday Required)
A. 1 mol of $\text{H}_2\text{O}$ to $\text{O}_2$	3F
B. 1 mol of $\text{MnO}_4^-$ to $\text{Mn}^{2+}$	2F
C. 1.5 mol of Ca from molten $\text{CaCl}_2$	1F
D. 1 mol of $\text{FeO}$ to $\text{Fe}_2\text{O}_3$	5F

Choose the correct answer from the options given below:

- (1) A-II, B-IV, C-I, D-III
  - (2) A-III, B-IV, C-I, D-II
  - (3) A-II, B-III, C-I, D-IV
  - (4) A-III, B-IV, C-II, D-I
- 

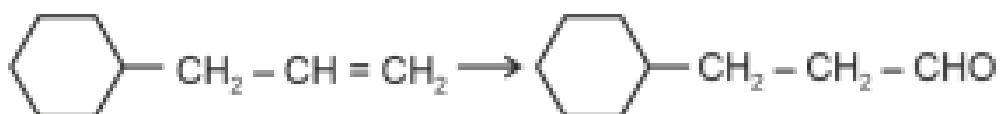
**55. Identify the correct reagents that would bring about the following transformation.**

- (1) (i)  $\text{H}_2\text{O}/\text{H}^+$ , (ii)  $\text{CrO}_3$
  - (2) (i)  $\text{BH}_3$ , (ii)  $\text{H}_2\text{O}_2/\text{OH}^-$ , (iii) PCC
  - (3) (i)  $\text{BH}_3$ , (ii)  $\text{H}_2\text{O}_2/\text{OH}^-$ , (iii) alk.  $\text{KMnO}_4$ , (iv)  $\text{H}_3\text{O}^+$
  - (4) (i)  $\text{H}_2\text{O}/\text{H}^+$ , (ii) PCC
-

56. Intramolecular hydrogen bonding is present in:

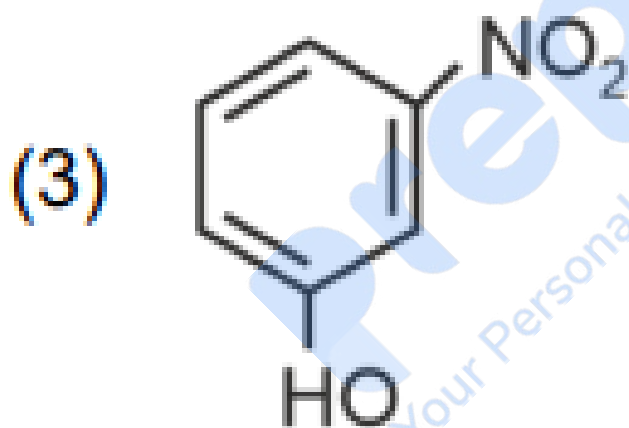
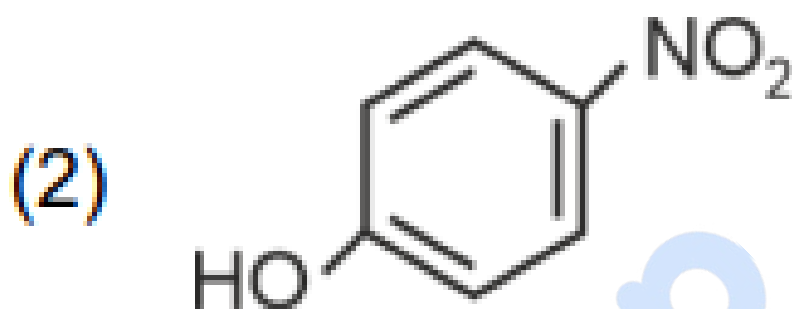
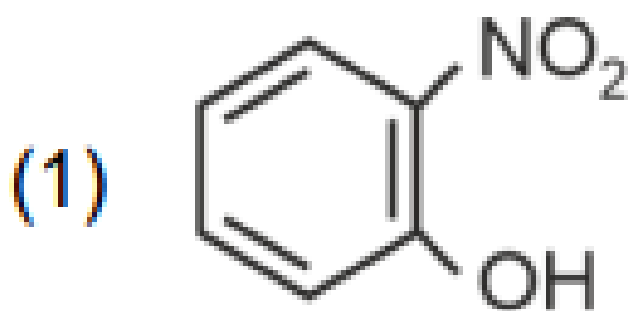

---

57. Activation energy of any chemical reaction can be calculated if one knows the value of:

- (1) rate constant at standard temperature
- (2) probability of collision

- (3) orientation of reactant molecules during collision  
 (4) rate constant at two different temperatures

58. Match List I with List II:

List I (Complex)	List II (Type of isomerism)
A. $[\text{Co}(\text{NH}_3)_5(\text{NO}_2)]\text{Cl}_2$	Solvate isomerism
B. $[\text{Co}(\text{NH}_3)_5(\text{SO}_4)]\text{Br}$	Linkage isomerism
C. $[\text{Co}(\text{NH}_3)_6][\text{Cr}(\text{CN})_6]$	Ionization isomerism
D. $[\text{Co}(\text{H}_2\text{O})_6]\text{Cl}_3$	Coordination isomerism

- (1) A-II, B-III, C-IV, D-I  
 (2) A-I, B-III, C-IV, D-II  
 (3) A-I, B-IV, C-III, D-II  
 (4) A-II, B-IV, C-III, D-I

59. 1 gram of sodium hydroxide was treated with 25 mL of 0.75 M HCl solution, the mass of sodium hydroxide left unreacted is equal to:

- (1) 750 mg  
 (2) 250 mg  
 (3) Zero mg  
 (4) 200 mg

60. Arrange the following elements in increasing order of electronegativity: N, O, F, C, Si

- (1)  $\text{Si} < \text{C} < \text{N} < \text{O} < \text{F}$   
 (2)  $\text{Si} < \text{C} < \text{O} < \text{N} < \text{F}$   
 (3)  $\text{O} < \text{F} < \text{N} < \text{C} < \text{Si}$   
 (4)  $\text{F} < \text{O} < \text{N} < \text{C} < \text{Si}$

**61. Match List I with List II.**

List I (Process)	List II (Conditions)
A. Isothermal process	I. No heat exchange
B. Isochoric process	II. Carried out at constant temperature
C. Isobaric process	III. Carried out at constant volume
D. Adiabatic process	IV. Carried out at constant pressure

- (1) A-IV, B-III, C-II, D-I  
 (2) A-IV, B-II, C-III, D-I  
 (3) A-I, B-II, C-III, D-IV  
 (4) A-II, B-III, C-IV, D-I

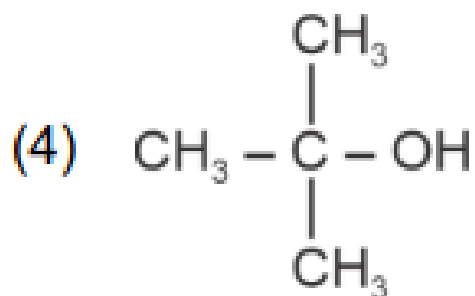
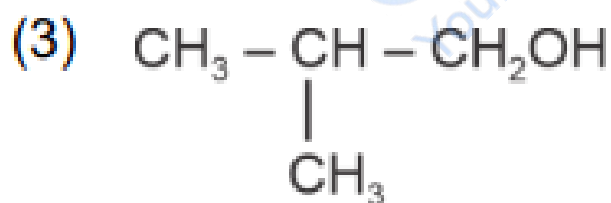
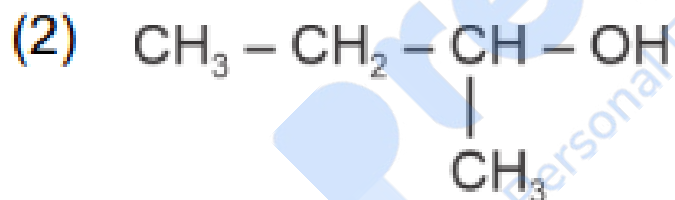
**62. Which one of the following alcohols reacts instantaneously with Lucas reagent?**

---

63. The energy of an electron in the ground state ( $n = 1$ ) for  $\text{He}^+$  ion is  $-x$  J, then that for an electron in  $n = 2$  state for  $\text{Be}^{3+}$  ion in J is:

- (1)  $-x$   
(2)  $-\frac{x}{9}$   
(3)  $-4x$   
(4)  $-\frac{4x}{9}$
- 

64. The compound that will undergo  $\text{S}_{\text{N}}1$  reaction with the fastest rate is:

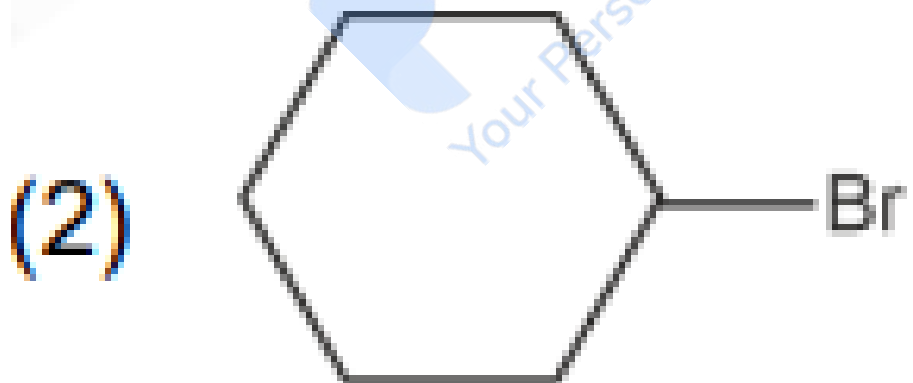

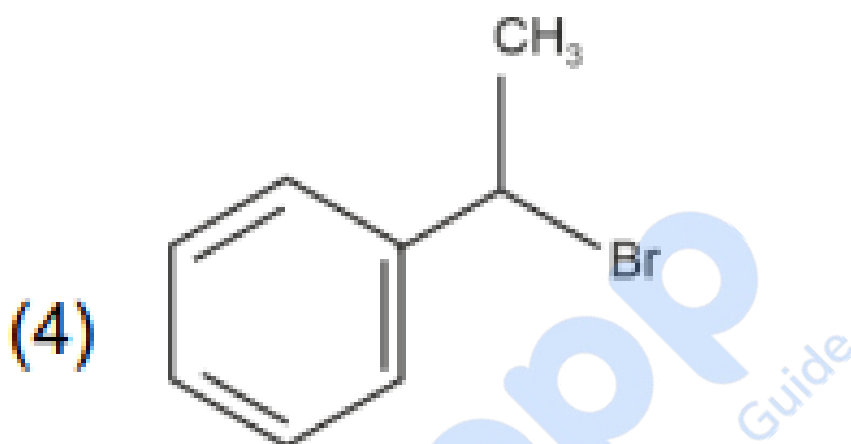
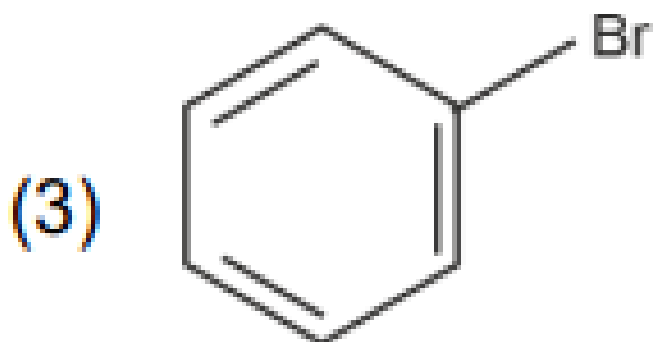

---

65. The Henry's law constant ( $K_H$ ) values of three gases (A, B, C) in water are 145,  $2 \times 10^{-5}$ , and 35 kbar, respectively. The solubility of these gases in water follow the order:

- (1)  $B > A > C$   
(2)  $B > C > A$   
(3)  $A > C > B$   
(4)  $A > B > C$

---

66. Which plot of  $\ln k$  vs  $\frac{1}{T}$  is consistent with the Arrhenius equation?

(1)

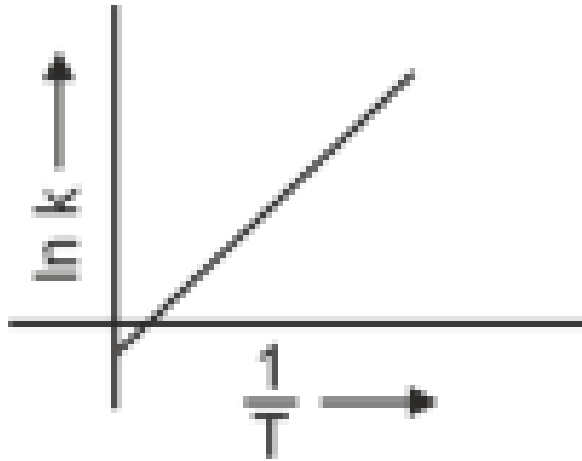

(2)

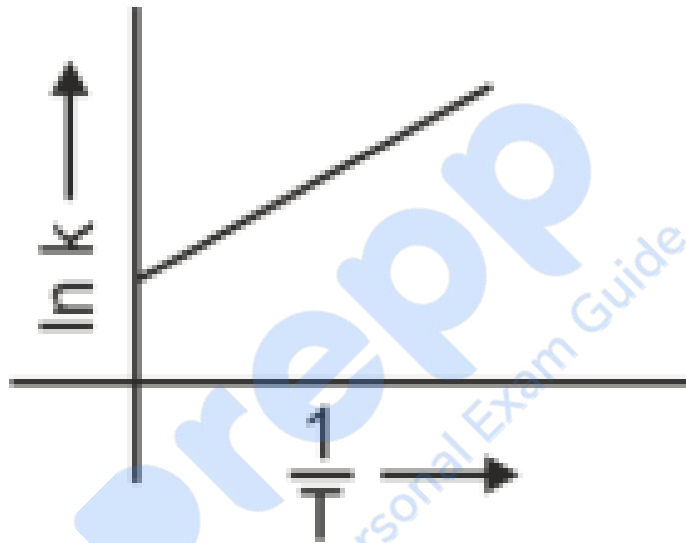

(3)

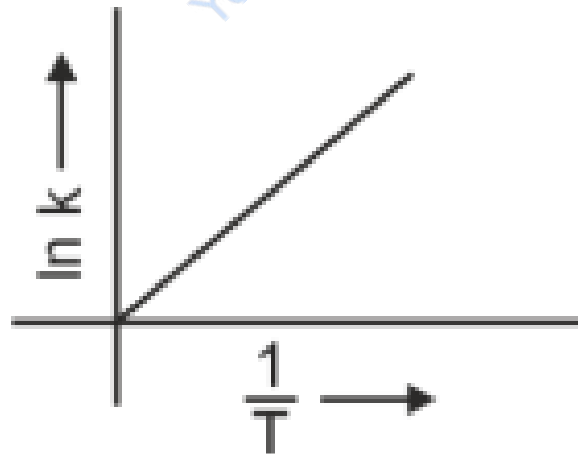

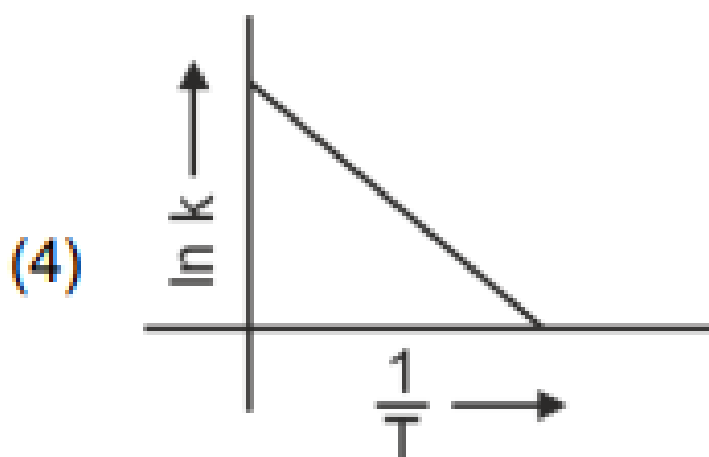

67. In which of the following equilibria,  $K_p$  and  $K_c$  are NOT equal?

- (1)  $\text{PCl}_5(g) \rightleftharpoons \text{PCl}_3(g) + \text{Cl}_2(g)$
- (2)  $\text{H}_2(g) + \text{I}_2(g) \rightleftharpoons 2\text{HI}(g)$
- (3)  $\text{CO}(g) + \text{H}_2\text{O}(g) \rightleftharpoons \text{CO}_2(g) + \text{H}_2(g)$
- (4)  $2\text{BrCl}(g) \rightleftharpoons \text{Br}_2(g) + \text{Cl}_2(g)$

68. Given below are two statements: **Statement I:** The boiling point of three isomeric pentanes follows the order



**Statement II:** When branching increases, the molecule attains a shape of sphere. This results in smaller surface area for contact, due to which the intermolecular forces between the spherical molecules are weak, thereby lowering the boiling point.

In light of the above statements, choose the most appropriate answer from the options given below:

- (1) Both Statement I and Statement II are correct
- (2) Both Statement I and Statement II are incorrect
- (3) Statement I is correct but Statement II is incorrect
- (4) Statement I is incorrect but Statement II is correct

---

**69. The reagents with which glucose does not react to give the corresponding tests/products are:**

- A. Tollen's reagent
- B. Schiff's reagent
- C. HCN
- D.  $\text{NH}_2\text{OH}$
- E.  $\text{NaHSO}_3$

Choose the correct options from the given below:

- (1) B and C
- (2) A and D
- (3) B and D
- (4) E and D

---

**70. In which of the following processes entropy increases?**

- (A) A liquid evaporates to vapour
- (B) Temperature of a crystalline solid lowered from 130 K to 0 K.
- (C)  $2\text{NaHCO}_3(s) \rightarrow \text{Na}_2\text{CO}_3(s) + \text{CO}_2(g) + \text{H}_2\text{O}(g)$
- (D)  $\text{Cl}_2(g) \rightarrow 2\text{Cl}(g)$

Choose the correct answer from the options given below:

- (1) A and C
- (2) A, B and D
- (3) A, C and D
- (4) C and D

---

**71. Match List I with List II.**

List I (Reaction)	List II (Reagents/Condition)
A. $C_6H_6 \rightarrow 2C_6H_5$	I. Cl/Anhyd. $AlCl_3$
B. $C_6H_5OH \rightarrow C_6H_5COOH$	II. $CrO_3$
C. $C_6H_5CH_3 \rightarrow C_6H_5COOH$	III. $KMnO_4/KOH, \Delta$
D. $C_6H_5CH_3 \rightarrow C_6H_4(CH_3)$	IV. $O_3, Zn-H_2O$

Choose the correct answer from the options given below:

- (1) A-IV, B-I, C-III, D-II
- (2) A-III, B-I, C-II, D-IV
- (3) A-IV, B-I, C-II, D-III
- (4) A-I, B-IV, C-II, D-III

**72. Given below are two statements: Statement I:** The boiling point of hydrides of Group 16 elements follows the order



**Statement II:** On the basis of molecular mass,  $H_2O$  is expected to have lower boiling point than the other members of the group but due to the presence of extensive H-bonding in  $H_2O$ , it has higher boiling point.

In light of the above statements, choose the correct answer from the options given below:

- (1) Both Statement I and Statement II are TRUE
- (2) Both Statement I and Statement II are false
- (3) Statement I is correct but Statement II is FALSE
- (4) Statement I is incorrect but Statement II is TRUE

**73. For the reaction  $2A \rightleftharpoons B + C$ ,  $K_c = 4 \times 10^{-3}$ . At a given time, the composition of reaction mixture is:**

$$[A] = [B] = [C] = 2 \times 10^{-3} M$$

Then, which of the following is correct?

- (1) Reaction is at equilibrium.
- (2) Reaction has a tendency to go in forward direction.
- (3) Reaction has a tendency to go in backward direction.
- (4) Reaction has gone to completion in forward direction.

**74. Match List I with List II.**

List I (Quantum Number)	List II (Information Provided)
$m$	Shape of orbital
$m_s$	Orientation of spin of electron
$l$	Size of orbital
$n$	Orientation of orbital

- (1) A-I, B-III, C-II, D-IV
- (2) A-III, B-IV, C-I, D-II
- (3) A-III, B-IV, C-II, D-I
- (4) A-II, B-I, C-IV, D-III

**75. A compound with a molecular formula of  $C_6H_{14}$  has two tertiary carbons. Its IUPAC name is:**

- (1) n-hexane
- (2) 2-methylpentane
- (3) 2,3-dimethylbutane
- (4) 2,2-dimethylbutane

**76. On heating, some solid substances change from solid to vapor state without passing through liquid state. The technique used for the purification of such solid substances based on the above principle is known as:**

- (1) Crystallization
- (2) Sublimation

- (3) Distillation  
(4) Chromatography

77. The most stable carbocation among the following is:

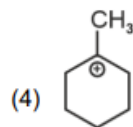
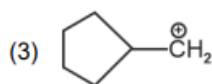
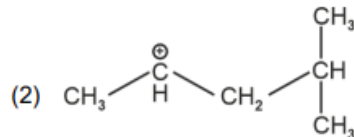
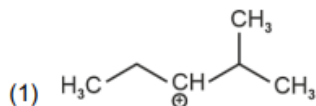

78. Given below are two statements: **Statement I:** Aniline does not undergo Friedel-Crafts alkylation reaction. **Statement II:** Aniline cannot be prepared through Gabriel synthesis.

In light of the above statements, choose the correct answer from the options given below:

- (1) Both statement I and Statement II are true  
(2) Both Statement I and Statement II are false  
(3) Statement I is correct but Statement II is false  
(4) Statement I is incorrect but Statement II is true

79. Which reaction is NOT a redox reaction?

- (1)  $\text{Zn} + \text{CuSO}_4 \rightarrow \text{ZnSO}_4 + \text{Cu}$   
(2)  $2\text{KClO}_3 \rightarrow 2\text{KCl} + \text{Cl}_2$   
(3)  $\text{H}_2 + \text{Cl}_2 \rightarrow 2\text{HCl}$   
(4)  $\text{BaCl}_2 + \text{Na}_2\text{SO}_4 \rightarrow \text{BaSO}_4 + 2\text{NaCl}$

80. Match List I with List II.

List I (Compound)	List II (Shape/geometry)
A. $\text{NH}_3$	I. Trigonal Pyramidal
B. $\text{Br}_5$	II. Square Planar
C. $\text{XeF}_4$	III. Octahedral
D. $\text{SF}_6$	IV. Square Pyramidal

- (1) A-I, B-IV, C-II, D-III  
 (2) A-II, B-IV, C-III, D-I  
 (3) A-III, B-IV, C-I, D-II  
 (4) A-II, B-III, C-IV, D-I

**81. Arrange the following elements in increasing order of first ionization enthalpy: Li, Be, B, C, N**

- (1)  $Li < Be < B < C < N$   
 (2)  $Li < B < Be < C < N$   
 (3)  $Li < Be < C < B < N$   
 (4)  $Li < Be < N < C < B$

**82. 'Spin only' magnetic moment is same for which of the following ions?**

- A.  $\text{Ti}^{3+}$   
 B.  $\text{Cr}^{2+}$   
 C.  $\text{Mn}^{2+}$   
 D.  $\text{Fe}^{2+}$   
 E.  $\text{Sc}^{3+}$

Choose the most appropriate answer from the options given below.

- (1) B and D only  
 (2) A and E only  
 (3) B and C only

(4) A and D only

---

**83. The  $E^\circ$  value for the  $\text{Mn}^{3+}/\text{Mn}^{2+}$  couple is more positive than that of  $\text{Cr}^{3+}/\text{Cr}^{2+}$  or  $\text{Fe}^{3+}/\text{Fe}^{2+}$  due to change of:**

- (1)  $d^5$  to  $d^4$  configuration
  - (2)  $d^5$  to  $d^2$  configuration
  - (3)  $d^4$  to  $d^5$  configuration
  - (4)  $d^3$  to  $d^5$  configuration
- 

**84. The highest number of helium atoms is in:**

- (1) 4 mol of helium
  - (2) 4 u of helium
  - (3) 3 g of helium
  - (4) 2.271098 L of helium at STP
- 

**85. Given below are two statements:**

**Statement I:** Both  $[\text{Co}(\text{NH}_3)_6]^{3+}$  and  $[\text{CoF}_6]^{3-}$  complexes are octahedral but differ in their magnetic behaviour. **Statement II:**  $[\text{Co}(\text{NH}_3)_6]^{3+}$  is diamagnetic whereas  $[\text{CoF}_6]^{3-}$  is paramagnetic.

In the light of the above statements, choose the correct answer from the options given below:

- (1) Both Statement I and Statement II are correct
  - (2) Both Statement I and Statement II are incorrect
  - (3) Statement I is correct but Statement II is false
  - (4) Statement I is false but Statement II is correct
- 

**86. The pair of lanthanoid ions which are diamagnetic is:**

- (1)  $\text{Ce}^{4+}$  and  $\text{Yb}^{2+}$

- (2)  $\text{Ce}^{3+}$  and  $\text{Eu}^{2+}$   
 (3)  $\text{Gd}^{3+}$  and  $\text{Eu}^{3+}$   
 (4)  $\text{Pm}^{3+}$  and  $\text{Sm}^{3+}$

**87. Given below are certain cations. Using inorganic qualitative analysis, arrange them in increasing group number from 0 to VI.**

- A.  $\text{Al}^{3+}$   
 B.  $\text{Cu}^{2+}$   
 C.  $\text{Ba}^{2+}$   
 D.  $\text{Co}^{2+}$   
 E.  $\text{Mg}^{2+}$

Choose the correct answer from the options given below:

- (1) B, A, D, C, E  
 (2) B, C, A, D, E  
 (3) E, C, D, B, A  
 (4) E, A, B, C, D

**88. Major products A and B formed in the following reaction sequence, are:**

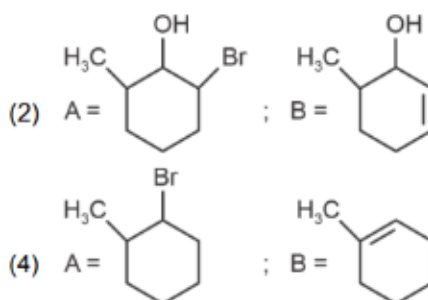
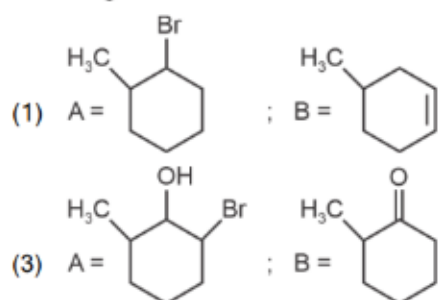
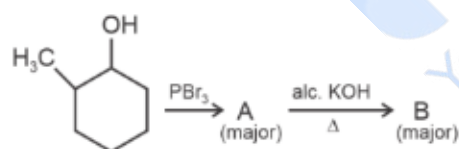

89. The work done during reversible isothermal expansion of one mole of hydrogen gas at 25°C from pressure of 20 atmosphere to 10 atmosphere is: (Given  $R = 2.0 \text{ cal K}^{-1} \text{ mol}^{-1}$ )

- (1) 0 calorie
- (2) -413.14 calories
- (3) 413.14 calories
- (4) 100 calories

90. Identify the major product C formed in the following reaction sequence:

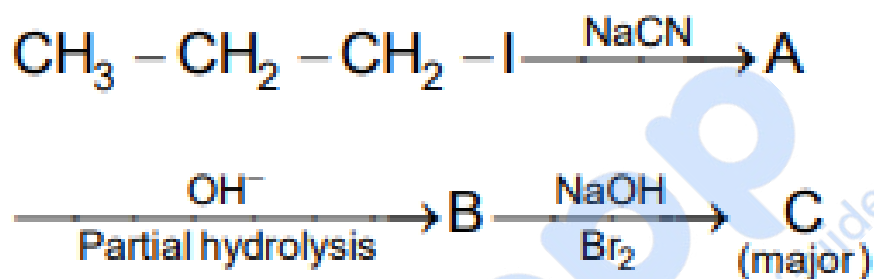

- (1) propylamine
- (2) butylamine
- (3) butanamide
- (4)  $\alpha$ -bromobutanoic acid

91. The products A and B obtained in the following reactions, respectively, are

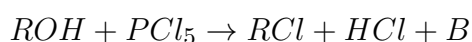
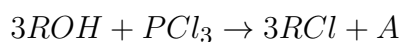

- (1)  $\text{POCl}_3$  and  $\text{H}_3\text{PO}_3$
- (2)  $\text{POCl}_3$  and  $\text{H}_3\text{PO}_4$
- (3)  $\text{H}_3\text{PO}_4$  and  $\text{POCl}_3$

(4)  $\text{H}_3\text{PO}_3$  and  $\text{POCl}_3$

---

**92. Mass in grams of copper deposited by passing 9.6487 A current through a voltmeter containing copper sulphate solution for 100 seconds is (Given: Molar mass of Cu = 63 g  $\text{mol}^{-1}$ , 1 F = 96487 C)**

- (1) 3.15 g
  - (2) 0.315 g
  - (3) 31.5 g
  - (4) 0.0315 g
- 

**93. A compound X contains 32% of A, 20% of B and the remaining percentage of C. Then, the empirical formula of X is: (Given atomic masses of A = 64, B = 40, C = 32 u)**

- (1)  $\text{A}_2\text{BC}_2$
  - (2)  $\text{ABC}_3$
  - (3)  $\text{AB}_2\text{C}_2$
  - (4)  $\text{ABC}_4$
- 

**94. During the preparation of Mohr's salt solution (Ferrous ammonium sulphate), which of the following acid is added to prevent hydrolysis of  $\text{Fe}^{2+}$  ion?**

- (1) dilute hydrochloric acid
  - (2) concentrated sulphuric acid
  - (3) dilute nitric acid
  - (4) dilute sulphuric acid
- 

**95. Identify the correct answer.**

- (1) Three resonance structures can be drawn for ozone.
- (2)  $\text{BF}_3$  has non-zero dipole moment.
- (3) Dipole moment of  $\text{NF}_3$  is greater than that of  $\text{NH}_3$ .

(4) Three canonical forms can be drawn for  $\text{CO}_3^{2-}$  ion.

---

**96. The rate of a reaction quadruples when temperature changes from  $27^\circ\text{C}$  to  $57^\circ\text{C}$ .**

**Calculate the energy of activation.** Given  $R = 8.314 \text{ J K}^{-1} \text{ mol}^{-1}$ ,  $\log 4 = 0.6021$

- (1) 38.04 kJ/mol
  - (2) 380.4 kJ/mol
  - (3) 3.80 kJ/mol
  - (4) 3804 kJ/mol
- 

**97. For the given reaction:**

  
Your Personal Exam Guide

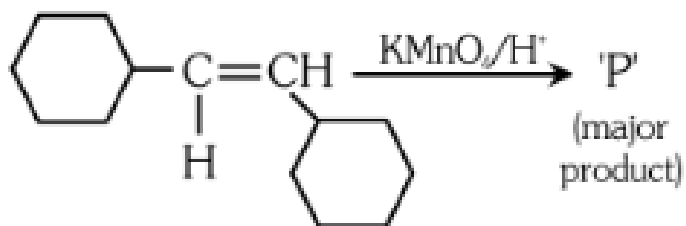

'P' is

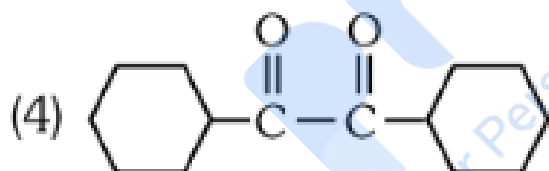
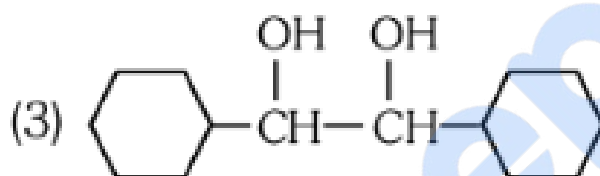

98. The plot of osmotic pressure ( $\Pi$ ) vs concentration ( $\text{mol L}^{-1}$ ) for a solution gives a straight line with slope  $25.73 \text{ L bar mol}^{-1}$ . The temperature at which the osmotic pressure measurement is done is (Use  $R = 0.083 \text{ L bar mol}^{-1}\text{K}^{-1}$ )

- (1)  $37^\circ\text{C}$
- (2)  $310^\circ\text{C}$
- (3)  $25.73^\circ\text{C}$
- (4)  $12.05^\circ\text{C}$

---

**99. Given below are two statements:**

Statement I:  $[Co(NH_3)_6]^{3+}$  is a homoleptic complex whereas  $[Co(NH_3)_4Cl_2]^+$  is a heteroleptic complex.

Statement II: Complex  $[Co(NH_3)_6]^{3+}$  has only one kind of ligands but  $[Co(NH_3)_4Cl_2]^+$  has more than one kind of ligands.

In the light of the above statements, choose the correct answer from the options given below:

- (1) Both Statement I and Statement II are true
- (2) Both Statement I and Statement II are false
- (3) Statement I is true but Statement II is false
- (4) Statement I is false but Statement II is true

---

**100. Consider the following reaction in a sealed vessel at equilibrium with concentrations of**

$$N_2 = 3.0 \times 10^{-3} \text{ M}, O_2 = 4.2 \times 10^{-3} \text{ M and NO} = 2.8 \times 10^{-3} \text{ M.}$$



If  $0.1 \text{ mol L}^{-1}$  of  $NO(g)$  is taken in a closed vessel, what will be degree of dissociation ( $\alpha$ ) of  $NO(g)$  at equilibrium?

- (1) 0.00889
- (2) 0.0889
- (3) 0.8889
- (4) 0.717

---

**BIOLOGY**

**101. Auxin is used by gardeners to prepare weed-free lawns. But no damage is caused to grass as auxin:**

- (1) promotes apical dominance.
  - (2) promotes abscission of mature leaves only.
  - (3) does not affect mature monocotyledonous plants.
  - (4) can help in cell division in grasses, to produce growth.
- 

**102. How many molecules of ATP and NADPH are required for every molecule of CO<sub>2</sub> fixed in the Calvin cycle?**

- (1) 2 molecules of ATP and 3 molecules of NADPH
  - (2) 2 molecules of ATP and 2 molecules of NADPH
  - (3) 3 molecules of ATP and 3 molecules of NADPH
  - (4) 3 molecules of ATP and 2 molecules of NADPH
- 

**103. In the given figure, which component has thin outer walls and highly thickened inner walls?**

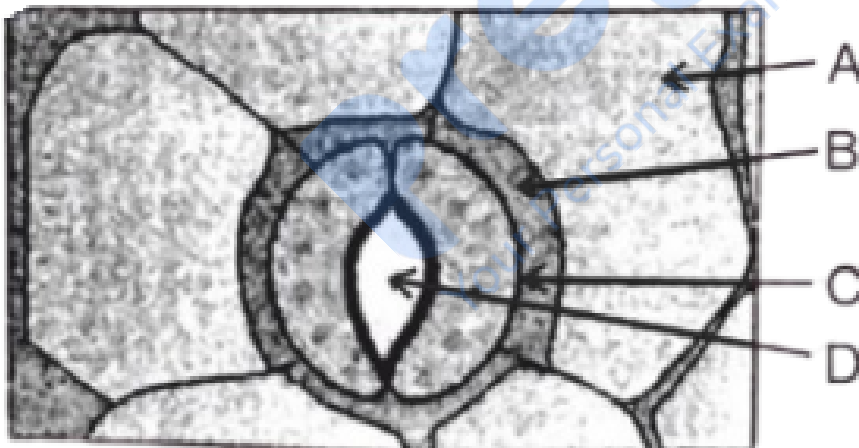

- (1) C
- (2) D
- (3) A
- (4) B

**104. Match List I with List II**

List-I	List-II
A. Nucleolus	I. Site of formation of glycolipid
B. Centriole	II. Organization like the cartwheel
C. Leucoplasts	III. Site for active ribosomal RNA synthesis
D. Golgi apparatus	IV. For storing nutrients

Choose the correct answer from the options given below:

- (1) A-III, B-II, C-IV, D-I
- (2) A-II, B-III, C-I, D-IV
- (3) A-III, B-IV, C-II, D-I
- (4) A-I, B-II, C-III, D-IV

**105. Identify the type of flowers based on the position of calyx, corolla and androecium with respect to the ovary from the given figures (a) and (b)**

- (1) (a) Epigynous; (b) Hypogynous
- (2) (a) Hypogynous; (b) Epigynous

(3) (a) Perigynous; (b) Epigynous

(4) (a) Perigynous; (b) Perigynous

---

**106. Match List I with List II**

List-I	List-II
A. Rhizopus	I. Mushroom
B. Ustilago	II. Smut fungus
C. Puccinia	III. Bread mould
D. Agaricus	IV. Rust fungus

Choose the correct answer from the options given below:

(1) A-III, B-II, C-IV, D-I

(2) A-I, B-III, C-II, D-IV

(3) A-III, B-II, C-I, D-IV

(4) A-IV, B-III, C-II, D-I

---

**107. Which of the following is an example of actinomorphic flower?**

(1) Datura

(2) Cassia

(3) Pisum

(4) Sesbania

---

**108. Identify the set of correct statements:**

A. The flowers of Vallisneria are colourful and produce nectar.

- B. The flowers of water lily are not pollinated by water.
- C. In most of water-pollinated species, the pollen grains are protected from wetting.
- D. Pollen grains of some hydrophytes are long and ribbon-like.
- E. In some hydrophytes, the pollen grains are carried passively inside water.

Choose the correct answer from the options given below:

- (1) C, D and E only
- (2) A, B, C and D only
- (3) A, C, D and E only
- (4) B, C, D and E only

---

**109. A pink flowered Snapdragon plant was crossed with a red flowered Snapdragon plant. What type of phenotype/s is/are expected in the progeny?**

- (1) Only red flowered plants
- (2) Red flowered as well as pink flowered plants
- (3) Only pink flowered plants
- (4) Red, Pink as well as white flowered plants

---

**110. Formation of interfascicular cambium from fully developed parenchyma cells is an example for**

- (1) Differentiation
- (2) Redifferentiation
- (3) Dedifferentiation
- (4) Maturation

---

**111. Match List I with List II**

List-I	List-II
A. Two or more alternative forms of a gene	I. Back cross
B. Cross of F1 progeny with homozygous	II. Ploidy
C. Cross of F1 progeny with any of the parents	III. Allele
D. Number of chromosome sets in plant	IV. Test cross

Choose the correct answer from the options given below:

- (1) A-I, B-II, C-III, D-IV  
 (2) A-II, B-I, C-III, D-IV  
 (3) A-III, B-IV, C-I, D-II  
 (4) A-IV, B-III, C-II, D-I

**112. Which of the following are required for the dark reaction of photosynthesis? A.**

Light

B. Chlorophyll

C. CO<sub>2</sub>

D. ATP

E. NADPH

Choose the correct answer from the options given below:

- (1) A, B and C only  
 (2) B, C and D only  
 (3) C, D and E only  
 (4) D and E only

**113. Given below are two statements:** Statement I: Chromosomes become gradually visible under light microscope during leptotene stage. Statement II: The beginning of diplotene stage is recognized by dissolution of synaptonemal complex.

In the light of the above statements, choose the correct answer from the options given

below:

- (1) Both Statement I and Statement II are true
  - (2) Both Statement I and Statement II are false
  - (3) Statement I is true but Statement II is false
  - (4) Statement I is false but Statement II is true
- 

**114. Spindle fibers attach to kinetochores of chromosomes during**

- (1) Prophase
  - (2) Metaphase
  - (3) Anaphase
  - (4) Telophase
- 

**115. What is the fate of a piece of DNA carrying only the gene of interest which is transferred into an alien organism?**

- A. The piece of DNA would be able to multiply itself independently in the progeny cells of the organism.
- B. It may get integrated into the genome of the recipient.
- C. It may multiply and be inherited along with the host DNA.
- D. The alien piece of DNA is not an integral part of the chromosome.
- E. It shows ability to replicate.

Choose the correct answer from the options given below:

- (1) A and B only
  - (2) D and E only
  - (3) B and C only
  - (4) A and E only
- 

**116. The lactose present in the growth medium of bacteria is transported to the cell by the action of**

- (1) Beta-galactosidase
  - (2) Acetylase
  - (3) Permease
  - (4) Polymerase
- 

**117. Given below are two statements:** Statement I: Parenchyma is living but collenchyma is dead tissue. Statement II: Gymnosperms lack xylem vessels but the presence of xylem vessels is the characteristic of angiosperms.

In the light of the above statements, choose the correct answer from the options given below:

- (1) Both Statement I and Statement II are true
  - (2) Both Statement I and Statement II are false
  - (3) Statement I is true but Statement II is false
  - (4) Statement I is false but Statement II is true
- 

**118. Which one of the following is not a criterion for classification of fungi?**

- (1) Morphology of mycelium
  - (2) Mode of nutrition
  - (3) Mode of spore formation
  - (4) Fruiting body
- 

**119. In a plant, black seed color (BB/Bb) is dominant over white seed color (bb). In order to find out the genotype of the black seed plant, with which of the following genotype will you cross it?**

- (1) BB
- (2) bb
- (3) Bb
- (4) BB/Bb

- 
- 120. Tropical regions show the greatest level of species richness because** A. Tropical latitudes have remained relatively undisturbed for millions of years, hence more time was available for species diversification.
- B. Tropical environments are more seasonal.
- C. More solar energy is available in tropics.
- D. Constant environments promote niche specialization.
- E. Tropical environments are constant and predictable.

Choose the correct answer from the options given below.

- (1) A, C, D and E only
- (2) A and B only
- (3) A, B and E only
- (4) A, B and D only

- 
- 121. These are regarded as major causes of biodiversity loss:** A. Over exploitation
- B. Co-extinction
- C. Mutation
- D. Habitat loss and fragmentation
- E. Migration

Choose the correct option:

- (1) A, C and D only
- (2) A, B, C and D only
- (3) A, B and E only
- (4) A, B and D only

- 
- 122. A transcription unit in DNA is defined primarily by the three regions in DNA and these are with respect to upstream and downstream end:**

- (1) Repressor, Operator gene, Structural gene
  - (2) Structural gene, Transposons, Operator gene
  - (3) Inducer, Repressor, Structural gene
  - (4) Promotor, Structural gene, Terminator
- 

**123. Hind II always cuts DNA molecules at a particular point called recognition sequence and it consists of:**

- (1) 8 bp
  - (2) 6 bp
  - (3) 4 bp
  - (4) 10 bp
- 

**124. The cofactor of the enzyme carboxypeptidase is:**

- (1) Zinc
  - (2) Niacin
  - (3) Flavin
  - (4) Haem
- 

**125. Match List I with List II**

List I	List II
A. <i>Clostridium butylicum</i>	I. Ethanol
B. <i>Saccharomyces cerevisiae</i>	II. Streptokinase
C. <i>Trichoderma polysporum</i>	III. Butyric acid
D. <i>Streptococcus sp.</i>	IV. Cyclosporin-A

Choose the correct answer from the options given below:

- (1) A-III, B-I, C-II, D-IV
- (2) A-II, B-IV, C-III, D-I
- (3) A-III, B-I, C-IV, D-II

(4) A-IV, B-I, C-III, D-II

---

**126. List of endangered species was released by:**

- (1) GEAC
  - (2) WWF
  - (3) FOAM
  - (4) IUCN
- 

**127. The type of conservation in which the threatened species are taken out from their natural habitat and placed in special setting where they can be protected and given special care is called:**

- (1) in-situ conservation
  - (2) Biodiversity conservation
  - (3) Semi-conservative method
  - (4) Sustainable development
- 

**128. The capacity to generate a whole plant from any cell of the plant is called:**

- (1) Totipotency
  - (2) Micropropagation
  - (3) Differentiation
  - (4) Somatic hybridization
- 

**129. The equation of Verhulst-Pearl logistic growth is  $\frac{dN}{dt} = rN \left( \frac{K-N}{K} \right)$ .**

**From this equation, K indicates:**

- (1) Intrinsic rate of natural increase
- (2) Biotic potential
- (3) Carrying capacity
- (4) Population density

---

**130. Bulliform cells are responsible for:**

- (1) Inward curling of leaves in monocots.
  - (2) Protecting the plant from salt stress.
  - (3) Increased photosynthesis in monocots.
  - (4) Providing large spaces for storage of sugars.
- 

**131. Lecithin, a small molecular weight organic compound found in living tissues, is an example of:**

- (1) Amino acids
  - (2) Phospholipids
  - (3) Glycerides
  - (4) Carbohydrates
- 

**132. Inhibition of Succinic dehydrogenase enzyme by malonate is a classical example of:**

- (1) Cofactor inhibition
  - (2) Feedback inhibition
  - (3) Competitive inhibition
  - (4) Enzyme activation
- 

**133. Given below are two statements:**

**Statement I:** Bt toxins are insect group specific and coded by a gene cry IAc.

**Statement II:** Bt toxin exists as inactive protoxin in *B. thuringiensis*. However, after ingestion by the insect, the inactive protoxin gets converted into active form due to the acidic pH of the insect gut.

In the light of the above statements, choose the correct answer from the options given below:

- (1) Both Statement I and Statement II are true
- (2) Both Statement I and Statement II are false

- (3) Statement I is true but Statement II is false  
(4) Statement I is false but Statement II is true
- 

**134. Identify the part of the seed from the given figure which is destined to form root when the seed germinates.**

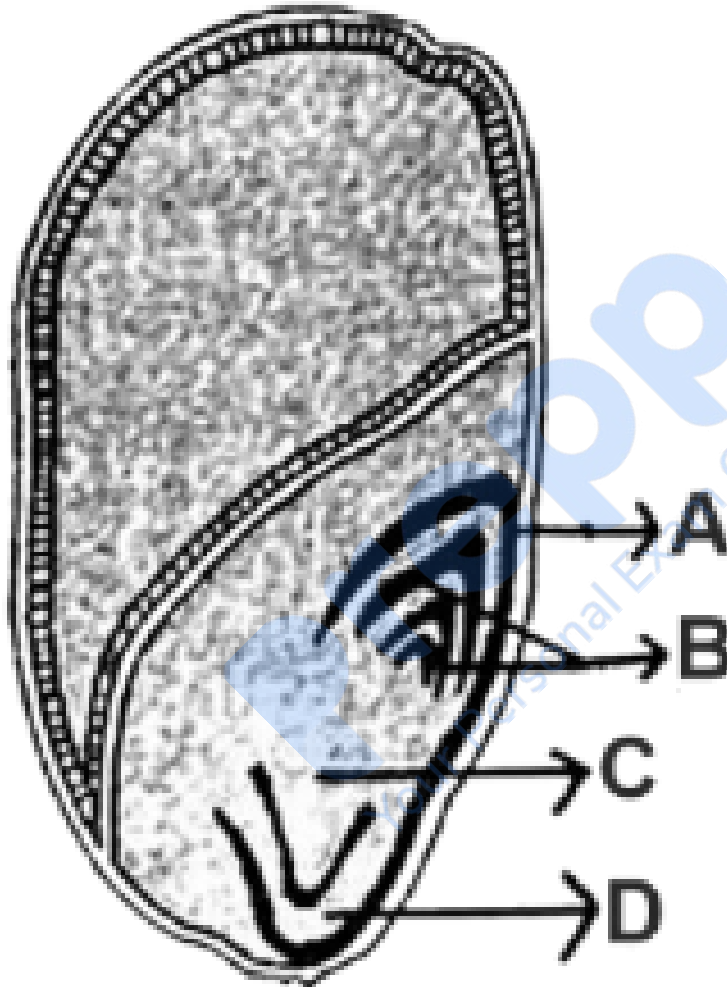

Choose the correct answer from the options given below:

- (1) A  
(2) B  
(3) C  
(4) D

**135. Which one of the following can be explained on the basis of Mendel's Law of Dominance?**

- A. Out of one pair of factors one is dominant and the other is recessive.
- B. Alleles do not show any expression and both the characters appear as such in F<sub>2</sub> generation.
- C. Factors occur in pairs in normal diploid plants.
- D. The discrete unit controlling a particular character is called factor.
- E. The expression of only one of the parental characters is found in a monohybrid cross.

Choose the correct answer from the options given below:

- (1) A, B and C only
- (2) A, C, D and E only
- (3) B, C and D only
- (4) A, B, C, D and E

**136. Match List I with List II**

List I	List II
A. Citric acid cycle	I. Cytoplasm
B. Glycolysis	II. Mitochondrial matrix
C. Electron transport system	III. Intermembrane space of mitochondria
D. Proton gradient	IV. Inner mitochondrial membrane

Choose the correct

answer from the options given below:

- (1) A-I, B-II, C-III, D-IV
- (2) A-II, B-I, C-IV, D-III
- (3) A-III, B-IV, C-I, D-II
- (4) A-IV, B-III, C-II, D-I

**137. Match List I with List II**

List I	List II
A. Robert May	I. Species-Area relationships
B. Alexander von Humboldt	II. Long term ecosystem experiment using outdoor plots
C. Paul Ehrlich	III. Global species diversity at about 7 million
D. David Tilman	IV. Rivet popper hypothesis

Choose the correct

answer from the options given below:

- (1) A-II, B-III, C-I, D-IV
- (2) A-III, B-I, C-IV, D-II
- (3) A-I, B-III, C-II, D-IV
- (4) A-III, B-IV, C-II, D-I

**138. In an ecosystem if the Net Primary Productivity (NPP) of first trophic level is  $100x \text{ kcal m}^{-2}\text{yr}^{-1}$ , what would be the GPP (Gross Primary Productivity) of the third trophic level of the same ecosystem?**

- (1)  $\frac{x}{10} (\text{kcal m}^{-2}\text{yr}^{-1})$
- (2)  $x (\text{kcal m}^{-2}\text{yr}^{-1})$
- (3)  $10x (\text{kcal m}^{-2}\text{yr}^{-1})$
- (4)  $100x/3X (\text{kcal m}^{-2}\text{yr}^{-1})$

**139. Read the following statements and choose the set of correct statements:**

In the members of Phaeophyceae,

- A. Asexual reproduction occurs usually by biflagellate zoospores.
- B. Sexual reproduction is by oogamous method only.
- C. Stored food is in the form of carbohydrates which is either mannitol or laminarin.
- D. The major pigments found are chlorophyll a, c and carotenoids and xanthophyll.
- E. Vegetative cells have a cellulosic wall, usually covered on the outside by gelatinous coating of algin.

Choose the correct answer from the options given below:

- (1) A, B, C and D only
- (2) B, C, D and E only

- (3) A, C, D and E only  
 (4) A, B, C and E only

**140. Spraying sugarcane crop with which of the following plant growth regulators increases the length of stem, thus increasing the yield?**

- (1) Auxin  
 (2) Gibberellin  
 (3) Cytokinin  
 (4) Abscisic acid

**141. Match List I with List II**

List I (Types of Stamens)	List II (Example)
A. Monoadelphous	I. Citrus
B. Diadelphous	II. Pea
C. Polyadelphous	III. Lily
D. Epiphyllous	IV. China-rose

Choose the correct answer from the options given below:

- (1) A-IV, B-II, C-I, D-III  
 (2) A-IV, B-I, C-II, D-III  
 (3) A-I, B-II, C-IV, D-III  
 (4) A-III, B-I, C-IV, D-II

**142. Which of the following statement is correct regarding the process of replication in E.coli?**

- (1) The DNA dependent DNA polymerase catalyses polymerization in one direction that is 3' → 5'

- (2) The DNA dependent RNA polymerase catalyses polymerization in one direction, that is  $5' \rightarrow 3'$
- (3) The DNA dependent DNA polymerase catalyses polymerization in  $5' \rightarrow 3'$  as well as  $3' \rightarrow 5'$  direction
- (4) The DNA dependent DNA polymerase catalyses polymerization in  $5' \rightarrow 3'$  direction
- 

**143. Identify the step in tricarboxylic acid cycle, which does not involve oxidation of substrate.**

- (1) Malic acid  $\rightarrow$  Oxaloacetic acid
- (2) Succinic acid  $\rightarrow$  Malic acid
- (3) Succinyl-CoA  $\rightarrow$  Succinic acid
- (4) Isocitrate  $\rightarrow$   $\alpha$  - ketoglutaric acid
- 

**144. Match List I with List II**

List I	List II
A. Frederick Griffith	I. Genetic code
B. Francois Jacob & Jacque Monod	II. Semi-conservative mode of DNA replication
C. Har Gobind Khorana	III. Transformation
D. Meselson & Stahl	IV. Lac operon

Choose the correct answer from the options given below:

- (1) A-III, B-II, C-I, D-IV
- (2) A-III, B-IV, C-I, D-II
- (3) A-II, B-III, C-IV, D-I
- (4) A-IV, B-I, C-II, D-III
- 

**145. Identify the correct description about the given figure:**



- (1) Wind pollinated plant inflorescence showing flowers with well exposed stamens.
- (2) Water pollinated flowers showing stamens with mucilaginous covering.
- (3) Cleistogamous flowers showing autogamy.
- (4) Compact inflorescence showing complete autogamy

---

**146. The DNA present in chloroplast is:**

- (1) Linear, double stranded
- (2) Circular, double stranded

- (3) Linear, single stranded  
 (4) Circular, single stranded

**147. Given below are two statements:**

**Statement I:** In C<sub>3</sub> plants, some O<sub>2</sub> binds to RuBisCO, hence CO<sub>2</sub> fixation is decreased.

**Statement II:** In C<sub>4</sub> plants, mesophyll cells show very little photorespiration while bundle sheath cells do not show photorespiration.

In the light of the above statements, choose the correct answer from the options given below:

- (1) Both Statement I and Statement II are true  
 (2) Both Statement I and Statement II are false  
 (3) Statement I is true but Statement II is false  
 (4) Statement I is false but Statement II is true

**148. Match List-I with List-II**

List-I	List-II
A. GLUT-4	I. Hormone
B. Insulin	II. Enzyme
C. Trypsin	III. Intercellular ground substance
D. Collagen	IV. Enables glucose transport into cells

Choose the correct answer from the options given below:

- (1) A-IV, B-I, C-II, D-III  
 (2) A-I, B-II, C-III, D-IV  
 (3) A-II, B-III, C-IV, D-I  
 (4) A-III, B-IV, C-I, D-II

**149. Match List I with List II**

List I	List II
A. Rose	I. Twisted aestivation
B. Pea	II. Perigynous flower
C. Cotton	III. Drupe
D. Mango	IV. Marginal placentation

Choose the correct answer from the options given below:

- (1) A-II, B-IV, C-I, D-III
- (2) A-I, B-II, C-III, D-IV
- (3) A-IV, B-III, C-II, D-I
- (4) A-II, B-III, C-IV, D-I

---

**150. Which of the following are fused in somatic hybridization involving two varieties of plants?**

- (1) Callus
- (2) Somatic embryos
- (3) Protoplasts
- (4) Pollens

---

**151. Match List I with List II**

List I	List II
A. Pleurobrachia	I. Mollusca
B. Radula	II. Ctenophora
C. Stomochord	III. Osteichthyes
D. Air bladder	IV. Hemichordata

Choose the correct

answer from the options given below:

- (1) A-IV, B-II, C-III, D-I
- (2) A-II, B-I, C-IV, D-III
- (3) A-II, B-IV, C-I, D-III
- (4) A-IV, B-III, C-II, D-I

**152. Following are the stages of cell division:**

- A. Gap 2 phase
- B. Cytokinesis
- C. Synthesis phase
- D. Karyokinesis
- E. Gap 1 phase

Choose the correct sequence of stages from the options given below:

- (1) C-E-D-A-B
- (2) E-B-D-A-C
- (3) B-D-E-A-C
- (4) E-C-A-D-B

**153. Match List I with List II:**

List I	List II
A. Common cold	I. Plasmodium
B. Haemozoin	II. Typhoid
C. Widal test	III. Rhinoviruses
D. Allergy	IV. Dust mites

Choose the correct answer from the options given below:

- (1) A-II, B-IV, C-III, D-I
- (2) A-I, B-III, C-II, D-IV
- (3) A-III, B-I, C-II, D-IV
- (4) A-IV, B-II, C-III, D-I

154. Match List I with List II:

List I	List II
A. Typhoid	I. Fungus
B. Leishmaniasis	II. Nematode
C. Ringworm	III. Protozoa
D. Filariasis	IV. Bacteria

Choose the correct answer from the options given below:

- (1) A-I, B-III, C-II, D-IV
- (2) A-IV, B-III, C-I, D-II
- (3) A-III, B-I, C-IV, D-II
- (4) A-II, B-IV, C-III, D-I

---

**155. The flippers of the Penguins and Dolphins are an example of:**

- (1) Adaptive radiation
  - (2) Natural selection
  - (3) Convergent evolution
  - (4) Divergent evolution
- 

**156. Following are the stages of the pathway for conduction of an action potential through the heart:**

- A. AV bundle
- B. Purkinje fibres
- C. AV node
- D. Bundle branches
- E. SA node

Choose the correct sequence of the pathway from the options given below:

- (1) E-C-A-D-B
  - (2) A-E-C-B-D
  - (3) B-D-E-C-A
  - (4) E-A-D-B-C
- 

**157. Which of the following statements is incorrect?**

- (1) A bio-reactor provides optimal growth conditions for achieving the desired product
  - (2) Most commonly used bio-reactors are of stirring type
  - (3) Bio-reactors are used to produce small scale bacterial cultures
  - (4) Bio-reactors have an agitator system, an oxygen delivery system, and foam control system
- 

**158. Which of the following is not a component of the Fallopian tube?**

- (1) Uterine fundus

- (2) Isthmus
  - (3) Infundibulum
  - (4) Ampulla
- 

**159. Given below are two statements:**

**Statement I:** In the nephron, the descending limb of the loop of Henle is impermeable to water and permeable to electrolytes.

**Statement II:** The proximal convoluted tubule is lined by simple columnar brush border epithelium and increases the surface area for reabsorption.

In the light of the above statements, choose the correct answer from the option given below:

- (1) Both Statement I and Statement II are true
  - (2) Both Statement I and Statement II are false
  - (3) Statement I is true but Statement II is false
  - (4) Statement I is false but Statement II is true
- 

**160. Which one of the following factors will not affect the Hardy-Weinberg equilibrium?**

- (1) Genetic recombination
  - (2) Genetic drift
  - (3) Gene migration
  - (4) Constant gene pool
- 

**161. Which of the following is not a steroid hormone?**

- (1) Cortisol
  - (2) Testosterone
  - (3) Progesterone
  - (4) Glucagon
- 

**162. Match List I with List II**

List I	List II
A. Non-medicated IUD	I. Multiload 375
B. Copper releasing IUD	II. Progestogens
C. Hormone releasing IUD	III. Lippes loop
D. Implants	IV. LNG-20

Choose the correct answer from the options given below:

- (1) A-III, B-I, C-II, D-IV
- (2) A-I, B-III, C-IV, D-II
- (3) A-IV, B-I, C-II, D-III
- (4) A-III, B-I, C-IV, D-II

**163. In both sexes of cockroach, a pair of jointed filamentous structures called anal cerci are present on:**

- (1) 5th segment
- (2) 10th segment
- (3) 8th and 9th segment
- (4) 11th segment

**164. Match List I with List II:**

List I	List II
A. Expiratory capacity	I. Expiratory reserve volume + Tidal vol + Inspiratory reserve vol
B. Functional residual capacity	II. Tidal volume + Expiratory reserve volume
C. Vital capacity	III. Tidal volume + Inspiratory reserve volume
D. Inspiratory capacity	IV. Expiratory reserve volume + Residual volume

Choose the correct

answer from the options given below:

- (1) A-II, B-IV, C-I, D-III
- (2) A-III, B-II, C-IV, D-I
- (3) A-II, B-I, C-IV, D-III

(4) A-I, B-III, C-II, D-IV

**165. Match List I with List II:**

List I	List II
A. Pons	I. Provides additional space for Neurons, regulates posture and balance.
B. Hypothalamus	II. Controls respiration and gastric secretions.
C. Medulla	III. Connects different regions of the brain.
D. Cerebellum	IV. Neuro secretory cells

Choose the correct

answer from the options given below:

- (1) A-II, B-III, C-I, D-IV
- (2) A-III, B-IV, C-II, D-I
- (3) A-I, B-II, C-III, D-IV
- (4) A-II, B-I, C-IV, D-III

**166. Given below are two statements:**

**Statement I:** The presence or absence of hymen is not a reliable indicator of virginity.

**Statement II:** The hymen is torn during the first coitus only.

In the light of the above statements, choose the correct answer from the options given below:

- (1) Both Statement I and Statement II are true
- (2) Both Statement I and Statement II are false
- (3) Statement I is true but Statement II is false

**167. The following diagram showing restriction sites in E. coli cloning vector pBR322.**

**Find the role of 'X' and 'Y' genes:**

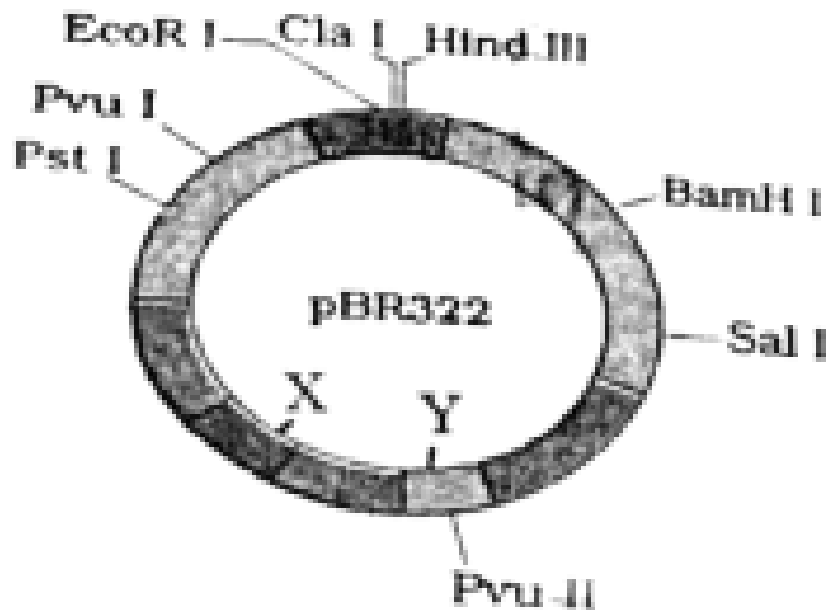

- (1) The gene 'X' is responsible for resistance to antibiotics and 'Y' for protein involved in the replication of Plasmid.
- (2) The gene 'X' is responsible for controlling the copy number of the linked DNA and 'Y' for protein involved in the replication of Plasmid.
- (3) The gene 'X' is for protein involved in replication of Plasmid and 'Y' for resistance to antibiotics.
- (4) Gene 'X' is responsible for recognitions sites and 'Y' is responsible for antibiotic resistance.

---

**168. Which one is the correct product of DNA dependent RNA polymerase to the given template?**

3' TACATGGCAAATATCCATTCA 5'

- (1) 5' AUGUACCGUUUUAUAGGUAAGU 3'
- (2) 5' AUGUAAAGUUUUAUAGGUAAGU 3'
- (3) 5' AUGUACCGUUUUAUAGGGAAGU 3'
- (4) 5' ATGTACCGTTTATAGGTAAGT 3'

**169. Which of the following are Autoimmune disorders?**

- A. Myasthenia gravis
- B. Rheumatoid arthritis
- C. Gout
- D. Muscular dystrophy
- E. Systemic Lupus Erythematosus (SLE)

Choose the most appropriate answer from the options given below:

- (1) A, B & D only
- (2) A, B & E only
- (3) B, C & E only
- (4) C, D & E only

**170. Match List I with List II:**

List I	List II
A. Pterophyllum	I. Hag fish
B. Myxine	II. Saw fish
C. Pristis	III. Angel fish
D. Exocoetus	IV. Flying fish

Choose the correct

answer from the options given below:

- (1) A-II, B-I, C-III, D-IV
- (2) A-III, B-I, C-II, D-IV
- (3) A-IV, B-I, C-II, D-III
- (4) A-III, B-II, C-I, D-IV

**171. Given below are two statements: one is labelled as Assertion (A) and the other is**

**labelled as Reason (R):**

**Assertion (A):** FSH acts upon ovarian follicles in females and Leydig cells in males.

**Reason (R):** Growing ovarian follicles secrete estrogen in females while interstitial cells secrete androgen in males.

In the light of the above statements, choose the correct answer from the options given below:

- (1) Both A and R are true and R is the correct explanation of A
- (2) Both A and R are true but R is NOT the correct explanation of A
- (3) A is true but R is false
- (4) A is false but R is true

**172. Match List I with List II:**

List I	List II
A. Lipase	I. Peptide bond
B. Nuclease	II. Ester bond
C. Protease	III. Glycosidic bond
D. Amylase	IV. Phosphodiester bond

Choose the correct

answer from the options given below:

- (1) A-IV, B-II, C-III, D-I
- (2) A-III, B-II, C-I, D-IV
- (3) A-II, B-IV, C-I, D-III
- (4) A-IV, B-I, C-III, D-II

**173. Match List I with List II:**

List I	List II
A. Axoneme	I. Centriole
B. Cartwheel pattern	II. Cilia and flagella
C. Crista	III. Chromosome
D. Satellite	IV. Mitochondria

Choose the correct

answer from the options given below:

- (1) A-IV, B-III, C-II, D-I
- (2) A-IV, B-II, C-III, D-I
- (3) A-II, B-IV, C-I, D-III
- (4) A-II, B-I, C-IV, D-III

**174. Match List I with List II:**

List I (Sub Phases of Prophase I)	List II (Specific Characters)
A. Diakinesis	I. Synaptonemal complex formation
B. Pachytene	II. Completion of terminalisation of chiasmata
C. Zygotene	III. Chromosomes look like thin threads
D. Leptotene	IV. Appearance of recombination nodules

Choose the correct

answer from the options given below:

- (1) A-IV, B-II, C-III, D-I
- (2) A-I, B-II, C-IV, D-III
- (3) A-II, B-IV, C-I, D-III
- (4) A-IV, B-III, C-II, D-I

**175. Consider the following statements:**

- A. Annelids are true coelomates
- B. Poriferans are pseudocoelomates

- C. Aschelminthes are acoelomates  
 D. Platyhelminthes are pseudocoelomates

Choose the correct answer from the options given below:

- (1) B only  
 (2) A only  
 (3) C only  
 (4) D only

**176. Match List I with List II:**

List I	List II
A. $\alpha$ -I antitrypsin	I. Cotton bollworm
B. Cry IAb	II. ADA deficiency
C. Cry IAc	III. Emphysema
D. Enzyme replacement therapy	IV. Corn borer

Choose the correct

answer from the options given below:

- (1) A-II, B-I, C-IV, D-III  
 (2) A-III, B-I, C-II, D-IV  
 (3) A-III, B-IV, C-I, D-II  
 (4) A-II, B-IV, C-I, D-III

**177. Match List I with List II:**

List I	List II
A. Fibrous joints	I. Adjacent vertebrae, limited movement
B. Cartilaginous joints	II. Humerus and Pectoral girdle, rotational movement
C. Hinge joints	III. Skull, don't allow any movement
D. Ball and socket joints	IV. Knee, help in locomotion

Choose the correct answer from the options given below:

- (1) A-IV, B-II, C-III, D-I  
 (2) A-I, B-III, C-II, D-IV

(3) A-II, B-III, C-I, D-IV

(4) A-III, B-I, C-IV, D-II

**178. Three types of muscles are given as a, b, and c. Identify the correct matching pair along with their location in the human body:**

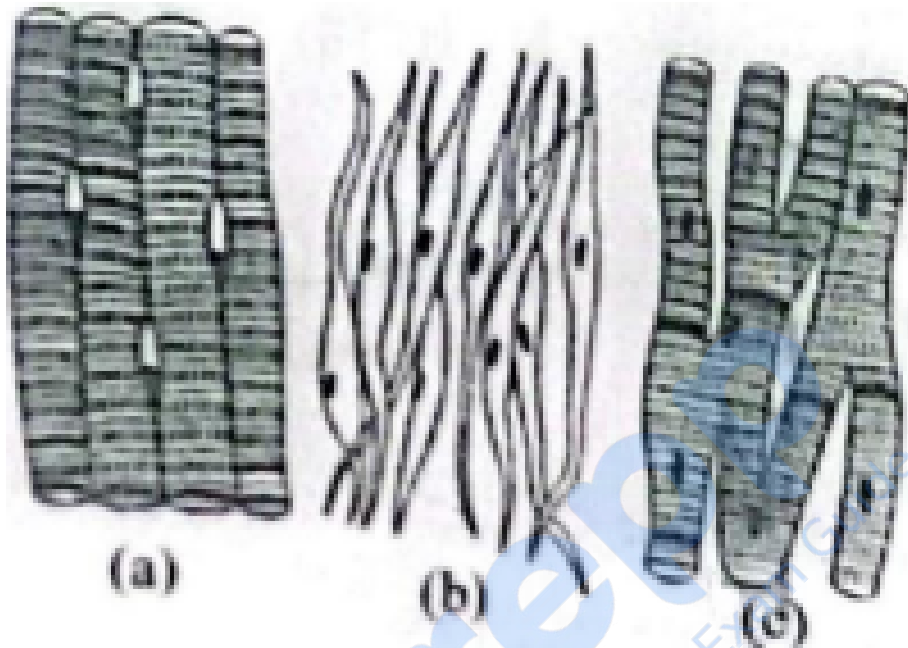

Name of muscle/location

(1) (a) Smooth - Toes, (b) Skeletal – Legs, (c) Cardiac – Heart

(2) (a) Skeletal - Triceps, (b) Smooth – Stomach, (c) Cardiac – Heart

(3) (a) Skeletal - Biceps, (b) Involuntary – Intestine, (c) Smooth – Heart

(4) (a) Involuntary – Nose tip, (b) Skeletal – Bone, (c) Cardiac – Heart

**179. Match List I with List II:**

List I	List II
A. Down's syndrome	I. 11 <sup>th</sup> chromosome
B. $\alpha$ -Thalassemia	II. X chromosome
C. $\beta$ -Thalassemia	III. 21 <sup>st</sup> chromosome
D. Klinefelter's syndrome	IV. 16 <sup>th</sup> chromosome

- (1) A-I, B-II, C-III, D-IV  
 (2) A-II, B-III, C-IV, D-I  
 (3) A-III, B-IV, C-I, D-II  
 (4) A-IV, B-I, C-II, D-III

**180. Which of the following factors are favorable for the formation of oxyhaemoglobin in alveoli?**

- (1) High pO<sub>2</sub> and High pCO<sub>2</sub>  
 (2) High pO<sub>2</sub> and Lesser H<sup>+</sup> concentration  
 (3) Low pCO<sub>2</sub> and High H<sup>+</sup> concentration  
 (4) Low pCO<sub>2</sub> and High temperature

**181. Given below are some stages of human evolution. Arrange them in correct sequence. (Past to Recent)**

- A. Homo habilis
- B. Homo sapiens
- C. Homo neanderthalensis
- D. Homo erectus

Choose the correct sequence of human evolution from the options given below:

- (1) D-A-C-B  
 (2) B-A-D-C

(3) C-B-D-A

(4) A-D-C-B

**182. Match List I with List II:**

List I	List II
A. Cocaine	I. Effective sedative in surgery
B. Heroin	II. Cannabis sativa
C. Morphine	III. Erythroxyllum
D. Marijuana	IV. Papaver somniferum

Choose the correct answer from the options given below:

(1) A-IV, B-III, C-I, D-II

(2) A-I, B-III, C-II, D-IV

(3) A-II, B-I, C-III, D-IV

(4) A-III, B-IV, C-I, D-II

**183. Given below are two statements: One is labelled as Assertion (A) and the other is labelled as Reason (R): Assertion (A):** Breast-feeding during initial period of infant growth is recommended by doctors for bringing a healthy baby.

**Reason (R):** Colostrum contains several antibodies absolutely essential to develop resistance for the new born baby.

In the light of the above statements, choose the most appropriate answer from the options given below: (1) Both A and R are correct and R is the correct explanation of A

(2) Both A and R are correct but R is NOT the correct explanation of A

(3) A is correct but R is not correct

(4) A is not correct but R is correct

- 184. Which of the following is not a natural/traditional contraceptive method?** (1) Coitus interruptus
- (2) Periodic abstinence
- (3) Lactational amenorrhea
- (4) Vaults
- 

- 185. The “Ti plasmid” of Agrobacterium tumefaciens stands for** (1) Tumour inhibiting plasmid
- (2) Tumor independent plasmid
- (3) Tumor inducing plasmid
- (4) Temperature independent plasmid
- 

**186. Match List I with List II:**

List-I	List-II
A. Exophthalmic goiter	I. Excess secretion of cortisol, moon face & hyperglycemia.
B. Acromegaly	II. Hypo-secretion of thyroid hormone and stunted growth.
C. Cushing's syndrome	III. Hyper secretion of thyroid hormone & protruding eyeballs.
D. Cretinism	IV. Excessive secretion of growth hormone.

Choose the correct answer from the options given below:

- (1) A-I, B-III, C-II, D-IV
- (2) A-IV, B-II, C-I, D-III
- (3) A-III, B-IV, C-II, D-I
- (4) A-III, B-IV, C-I, D-II
- 

**187. Given below are two statements:** Statement I: Mitochondria and chloroplasts both are double-membrane-bound organelles. Statement II: The inner membrane of mitochondria is relatively less permeable, as compared to chloroplasts.

In the light of the above statements, choose the most appropriate answer from the options given below:

- (1) Both Statement I and Statement II are correct.

- (2) Both Statement I and Statement II are incorrect.
- (3) Statement I is correct but Statement II is incorrect.
- (4) Statement I is incorrect but Statement II is correct.

**188. Regarding the catalytic cycle of an enzyme action, select the correct sequential steps:** A. Substrate-enzyme complex formation. B. Free enzyme ready to bind with another substrate. C. Release of products. D. Chemical bonds of the substrate broken. E. Substrate binding to the active site.

Choose the correct answer from the options given below:

- (1) E, A, D, C, B
- (2) A, E, B, D, C
- (3) B, A, C, D, E
- (4) E, D, C, B, A

**189. Match List I with List II related to the digestive system of a cockroach:**

List I		List II	
A.	The structures used for storing of food	I.	Gizzard
B.	Ring of 6-8 blind tubules at junction of foregut and midgut.	II.	Gastric Caeca
C.	Ring of 100-150 yellow coloured thin filaments at junction of midgut and hindgut.	III.	Malpighian tubules
D.	The structures used for grinding the food.	IV.	Crop

Choose the correct answer from the options given below:

- (1) A-IV, B-II, C-III, D-I
- (2) A-I, B-II, C-III, D-IV
- (3) A-IV, B-III, C-II, D-I
- (4) A-III, B-II, C-IV, D-I

**190. The following are the statements about non-chordates:** A. Pharynx is perforated by gill slits. B. Notochord is absent. C. Central nervous system is dorsal. D. Heart is dorsal if present. E. Post-anal tail is absent.

Choose the most appropriate answer from the options given below:

- (1) A & C only
- (2) A, B & D only
- (3) B, D & E only
- (4) B, C & D only

**191. Choose the correct statement given below regarding juxtamedullary nephron.**

- (1) Juxtamedullary nephrons are located in the columns of Bertini.
- (2) Renal corpuscle of juxtamedullary nephron lies in the outer portion of the renal medulla.
- (3) Loop of Henle of juxtamedullary nephron runs deep into medulla.
- (4) Juxtamedullary nephrons outnumber the cortical nephrons.

**192. Given below are two statements:** Statement I: The cerebral hemispheres are connected by a nerve tract known as the corpus callosum. Statement II: The brain stem consists of the medulla oblongata, pons, and cerebrum.

In light of the above statements, choose the most appropriate answer from the options given below:

- (1) Both Statement I and Statement II are correct.
- (2) Both Statement I and Statement II are incorrect.
- (3) Statement I is correct but Statement II is incorrect.
- (4) Statement I is incorrect but Statement II is correct.

**193. Match List I with List II:**

List-I	List-II
A. P wave	I. Heart muscles are electrically silent.
B. QRS complex	II. Depolarization of ventricles.
C. T wave	III. Depolarization of atria.
D. T-P gap	IV. Repolarization of ventricles.

Choose the correct answer from the options given below:

- (1) A-I, B-III, C-IV, D-II
- (2) A-III, B-II, C-IV, D-I
- (3) A-II, B-III, C-I, D-IV
- (4) A-IV, B-II, C-I, D-III

**194. Match List I with List II:**

List-I	List-II
A. Mesozoic Era	I. Lower invertebrates
B. Proterozoic Era	II. Fish & Amphibia
C. Cenozoic Era	III. Birds & Reptiles
D. Paleozoic Era	IV. Mammals

Choose the correct answer from the options given below:

- (1) A-II, B-I, C-III, D-IV
- (2) A-III, B-I, C-II, D-IV
- (3) A-I, B-II, C-IV, D-III
- (4) A-III, B-I, C-IV, D-II

**195. As per ABO blood grouping system, the blood group of father is B+, mother is A+ and child is O+. Their respective genotype can be**

- A.  $I^B I^A / ii$
- B.  $I^B I^B / I^A I^A$
- C.  $I^A I^B / ii$
- D.  $I^A I^B / I^A I^i$
- E.  $ii / I^A I^B / I^A I^B$

- (1) A only
  - (2) B only
  - (3) C & B only
  - (4) D & E only
- 

**196. Given below are two statements:**

**Statement I:** Gause's competitive exclusion principle states that two closely related species competing for different resources cannot exist indefinitely.

**Statement II:** According to Gause's principle, during competition, the inferior will be eliminated. This may be true if resources are limiting.

In the light of the above statements, choose the correct answer from the options given below:

- (1) Both Statement I and Statement II are true.
  - (2) Both Statement I and Statement II are false.
  - (3) Statement I is true but Statement II is false.
  - (4) Statement I is false but Statement II is true.
- 

**197. Given below are two statements:**

**Statement I:** Bone marrow is the main lymphoid organ where all blood cells including lymphocytes are produced.

**Statement II:** Both bone marrow and thymus provide microenvironments for the development and maturation of T-lymphocytes.

In the light of the above statements, choose the most appropriate answer from the options given below:

- (1) Both Statement I and Statement II are correct.
  - (2) Both Statement I and Statement II are incorrect.
  - (3) Statement I is correct but Statement II is incorrect.
  - (4) Statement I is incorrect but Statement II is correct.
- 

**198. Match List I with List II:**

List I	List II
A. Unicellular glandular epithelium	I. Salivary glands
B. Compound epithelium	II. Pancreas
C. Multicellular glandular epithelium	III. Goblet cells of alimentary canal
D. Endocrine glandular epithelium	IV. Moist surface of buccal cavity

Choose the correct answer from the options given below:

- (1) A-II, B-I, C-III, D-IV
- (2) A-IV, B-III, C-I, D-II
- (3) A-III, B-IV, C-I, D-II
- (4) A-II, B-I, C-IV, D-III

**199. Match List I with List II:**

List I	List II
A. RNA polymerase III	I. snRNPs
B. Termination of transcription	II. Promotor
C. Splicing of Exons	III. Rho factor
D. TATA box	IV. SnRNAs, tRNA

Choose the correct answer from the options given below:

- (1) A-II, B-IV, C-I, D-III
- (2) A-III, B-II, C-IV, D-I
- (3) A-III, B-IV, C-I, D-II
- (4) A-IV, B-III, C-I, D-II

**200. Identify the correct option (A), (B), (C), (D) with respect to spermatogenesis.**

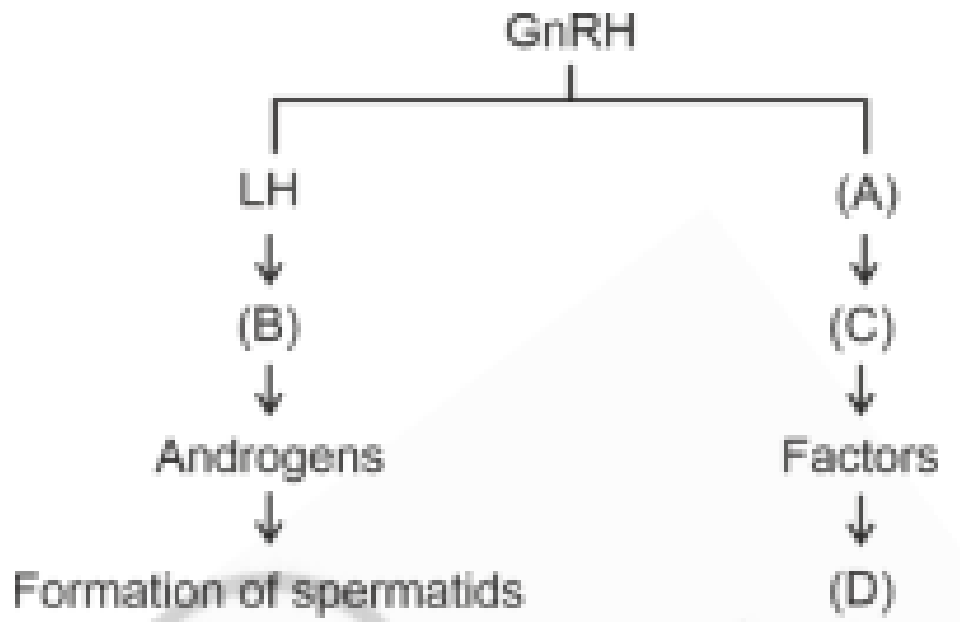

- (1) FSH, Leydig cells, Sertoli cells, spermiogenesis.
  - (2) ICSH, Interstitial cells, Leydig cells, spermiogenesis.
  - (3) FSH, Sertoli cells, Leydig cells, spermatogenesis.
  - (4) ICSH, Leydig cells, Sertoli cells, spermatogenesis.
-