

## NEET 2024 Question Paper Set T2

Time Allowed :3 Hours 20 min	Maximum Marks :720	Total Questions :200
------------------------------	--------------------	----------------------

### General Instructions

**Read the following instructions very carefully and strictly follow them::**

1. The test is of **3 hours 20 minutes** duration and the Test Booklet contains **200** multiple-choice questions (four options with a single correct answer) from **Physics, Chemistry, and Biology (Botany and Zoology)**. 50 questions in each subject are divided into **two Sections (A and B)** as per details given below:
  - (a) **Section-A** shall consist of **35 (Thirty-five)** Questions in each subject (Question Nos-1 to 35, 51 to 85, 101 to 135, and 151 to 185). All Questions are compulsory.
  - (b) **Section-B** shall consist of **15 (Fifteen)** questions in each subject (Question Nos- 36 to 50, 86 to 100, 136 to 150, and 186 to 200). In **Section B**, a candidate needs to attempt **any 10 (Ten)** questions out of **15 (Fifteen)** in each subject.

**Candidates are advised to read all 15 questions in each subject of Section B before they start attempting the question paper. In the event of a candidate attempting more than ten questions, the first ten questions answered by the candidate shall be evaluated.**

2. Each question carries **4 marks**. For each correct response, the candidate will get **4 marks**. For each incorrect response, **one mark will be deducted** from the total scores. **The maximum marks are 720.**
3. On completion of the test, the candidate must **hand over the Answer Sheet (ORIGINAL and OFFICE copy) to the Invigilator** before leaving the Room / Hall. The candidates are allowed to take away this Test Booklet with them.

## Physics

### SECTION -A

1. A wheel of a bullock cart is rolling on a level road as shown in the figure. If its linear speed is  $v$  in the direction shown, which one of the following options is correct (P and Q are the highest and lowest points on the wheel, respectively)?

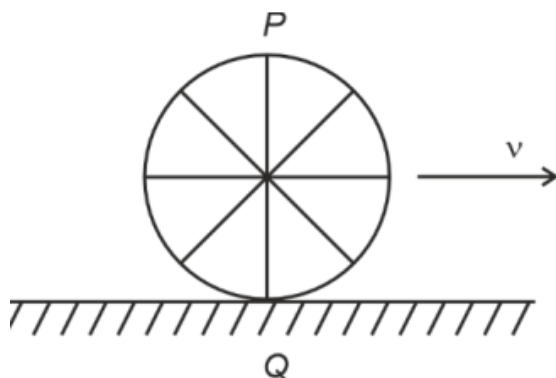

- (1) Both the points  $P$  and  $Q$  move with equal speed
- (2) Point  $P$  has zero speed
- (3) Point  $P$  moves slower than point  $Q$
- (4) Point  $P$  moves faster than point  $Q$

2. An unpolarised light beam strikes a glass surface at Brewster's angle. Then

- (1) Both the reflected and refracted light will be completely polarised.
- (2) The reflected light will be completely polarised but the refracted light will be partially polarised.
- (3) The reflected light will be partially polarised.
- (4) The refracted light will be completely polarised.

3. In a uniform magnetic field of  $0.049\text{ T}$ , a magnetic needle performs **20 complete oscillations in 5 seconds**. The moment of inertia of the needle is  $9.8 \times 10^{-6}\text{ kg m}^2$ . If the magnitude of magnetic moment of the needle is  $x \times 10^{-5}\text{ Am}^2$ , then the value of  $x$  is:

- (1)  $50\pi^2$
- (2)  $1280\pi^2$
- (3)  $5\pi^2$
- (4)  $128\pi^2$

4. Consider the following statements A and B and identify the correct answer:

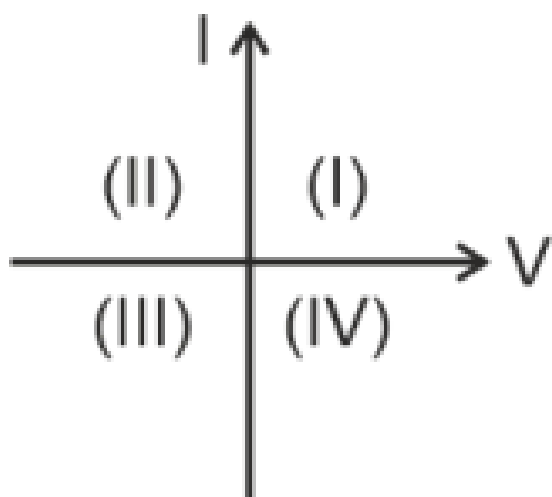

A. For a solar cell, the I-V characteristics lie in the IV quadrant of the given graph.  
 B. In a reverse biased  $pn$  junction diode, the current measured in  $\mu A$ , is due to majority charge carriers.

- (1) Both A and B are correct
- (2) Both A and B are incorrect
- (3) A is correct but B is incorrect
- (4) A is incorrect but B is correct

### 5. Match List I with List II.

List I (Spectral Lines of Hydrogen for transitions from)	List II (Wavelengths (nm))
A. $n_2 = 3$ to $n_1 = 2$	I. 410.2
B. $n_2 = 4$ to $n_1 = 2$	II. 434.1
C. $n_2 = 5$ to $n_1 = 2$	III. 656.3
D. $n_2 = 6$ to $n_1 = 2$	IV. 486.1

Choose the correct answer from the options given below:

- (1) A-IV, B-III, C-I, D-II
- (2) A-I, B-II, C-III, D-IV
- (3) A-II, B-I, C-IV, D-III
- (4) A-III, B-IV, C-II, D-I

6. A thin spherical shell is charged by some source. The potential difference between the two points  $C$  and  $P$  (in V) shown in the figure is: (Take  $\frac{1}{4\pi\epsilon_0} = 9 \times 10^9$  SI units)

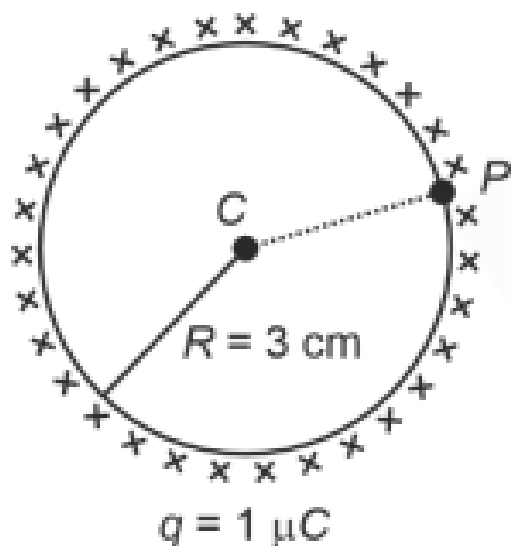

- (1)  $0.5 \times 10^5$
- (2) Zero
- (3)  $3 \times 10^5$
- (4)  $1 \times 10^5$

7. A thermodynamic system is taken through the cycle  $abcd$ . The work done by the gas along the path  $bc$  is:

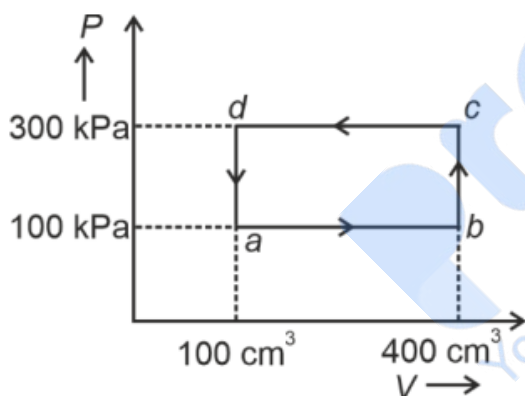

- (1)  $-90 \text{ J}$
- (2)  $-60 \text{ J}$
- (3) Zero
- (4)  $30 \text{ J}$

8. Two bodies  $A$  and  $B$  of same mass undergo a completely inelastic one-dimensional collision. The body  $A$  moves with velocity  $v_1$  while body  $B$  is at rest before the collision. The velocity of the system after collision is  $v_2$ . The ratio  $v_1 : v_2$  is:

- (1)  $4 : 1$
- (2)  $1 : 4$
- (3)  $1 : 2$
- (4)  $2 : 1$

9. A horizontal force of 10 N is applied to block A as shown in the figure. The masses of blocks A and B are 2 kg and 3 kg, respectively. The blocks slide over a frictionless surface. The force exerted by block A on block B is:

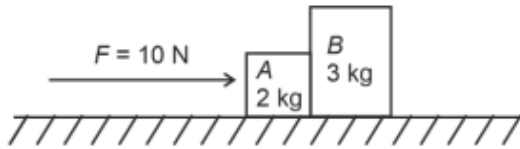

- (1) 6 N
- (2) 10 N
- (3) Zero
- (4) 4 N

10. If  $c$  is the velocity of light in free space, the correct statements about a photon among the following are:

- A. The energy of a photon is  $E = h\nu$ .
- B. The velocity of a photon is  $c$ .
- C. The momentum of a photon,  $p = \frac{h\nu}{c}$ .
- D. In a photon-electron collision, both total energy and total momentum are conserved.
- E. Photon possesses a positive charge.

Choose the correct answer from the options given below:

- (1) A, C, and D only
- (2) A, B, D, and E only
- (3) A and B only
- (4) A, B, C, and D only

11. At any instant of time  $t$ , the displacement of a particle is given by  $2t - 1$  (SI unit) under the influence of a force of 5 N. The value of instantaneous power is (in SI units):

- (1) 7
- (2) 6
- (3) 10
- (4) 5

12. If the monochromatic source in Young's double-slit experiment is replaced by white light, then:

- (1) There will be a central bright white fringe surrounded by a few coloured fringes
- (2) All bright fringes will be of equal width
- (3) Interference pattern will disappear
- (4) There will be a central dark fringe surrounded by a few coloured fringes

13. In the following circuit, the equivalent capacitance between terminal A and terminal B is:

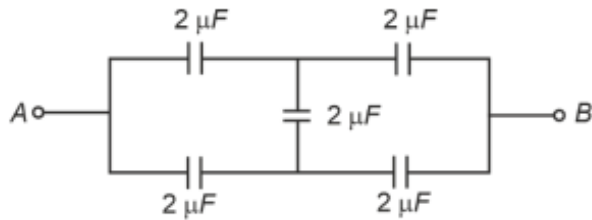

- (1)  $0.5 \mu F$
- (2)  $4 \mu F$
- (3)  $2 \mu F$
- (4)  $1 \mu F$

14. A light ray enters through a right-angled prism at point  $P$  with an angle of incidence  $30^\circ$  as shown in the figure. It travels through the prism parallel to its base  $BC$  and emerges along face  $AC$ . The refractive index of the prism is:

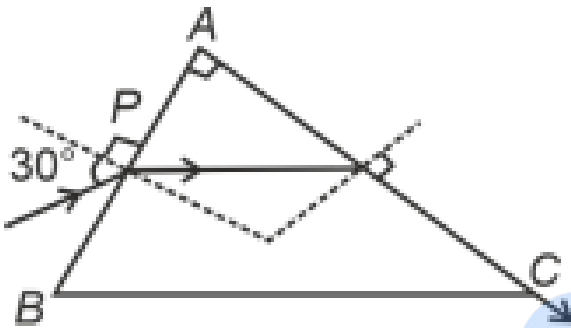

- (1)  $\frac{\sqrt{3}}{4}$
- (2)  $\frac{\sqrt{3}}{2}$
- (3)  $\frac{\sqrt{5}}{4}$
- (4)  $\frac{\sqrt{5}}{2}$

15. The output ( $Y$ ) of the given logic gate is similar to the output of an/a:

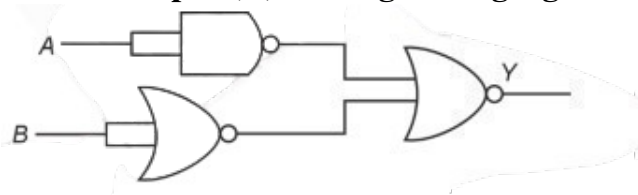

- (1) OR gate
- (2) AND gate
- (3) NAND gate
- (4) NOR gate

16. A particle moving with uniform speed in a circular path maintains:

- (1) Constant velocity but varying acceleration
- (2) Varying velocity and varying acceleration
- (3) Constant velocity

(4) Constant acceleration

---

**17. The quantities which have the same dimensions as those of solid angle are:**

- (1) strain and arc
  - (2) angular speed and stress
  - (3) strain and angle
  - (4) stress and angle
- 

**18. In a vernier callipers,  $(N + 1)$  divisions of the vernier scale coincide with  $N$  divisions of the main scale. If 1 MSD represents 0.1 mm, the vernier constant (in cm) is:**

- (1)  $\frac{100}{N}$
  - (2)  $10(N + 1)$
  - (3)  $\frac{1}{10N}$
  - (4)  $\frac{1}{100(N+1)}$
- 

**19. The terminal voltage of the battery, whose emf is 10 V and internal resistance  $1 \Omega$ , when connected through an external resistance of  $4 \Omega$  as shown in the figure is:**

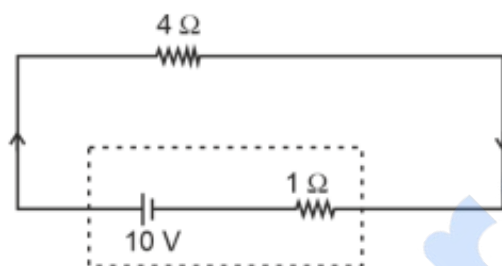

- (1) 8 V
  - (2) 10 V
  - (3) 4 V
  - (4) 6 V
- 

**20. A bob is whirled in a horizontal plane by means of a string with an initial speed of  $\omega$  rpm. The tension in the string is  $T$ . If speed becomes  $2\omega$  while keeping the same radius, the tension in the string becomes:**

- (1)  $\frac{T}{4}$
  - (2)  $\sqrt{2}T$
  - (3)  $T$
  - (4)  $4T$
- 

**21. If  $x = 5 \sin \left( \pi t + \frac{\pi}{3} \right)$  m represents the motion of a particle executing simple harmonic motion, the amplitude and time period of motion, respectively, are:**

- (1) 5 cm, 1 s
- (2) 5 m, 1 s
- (3) 5 cm, 2 s

(4) 5 m, 2 s

---

**22. In an ideal transformer, the turns ratio is  $\frac{N_p}{N_s} = \frac{1}{2}$ . The ratio  $V_s : V_p$  is equal to (the symbols carry their usual meaning):**

- (1) 1:1
  - (2) 1:4
  - (3) 1:2
  - (4) 2:1
- 

**23. Given below are two statements: one is labelled as Assertion A and the other is labelled as Reason R.**

**Assertion A:** The potential ( $V$ ) at any axial point, at 2 m distance ( $r$ ) from the centre of the dipole of dipole moment vector  $\vec{P}$  of magnitude,  $4 \times 10^{-6} \text{ C} \cdot \text{m}$ , is  $\pm 9 \times 10^3 \text{ V}$ .

(Take  $\frac{1}{4\pi\epsilon_0} = 9 \times 10^9 \text{ SI units}$ )

**Reason R:**

$$V = \pm \frac{2P}{4\pi\epsilon_0 r^2}$$

where  $r$  is the distance of any axial point, situated at 2 m from the centre of the dipole.

In the light of the above statements, choose the **correct answer** from the options given below:

- (1) A is true but R is false.
  - (2) A is false but R is true.
  - (3) Both A and R are true and R is the correct explanation of A.
  - (4) Both A and R are true and R is NOT the correct explanation of A.
- 

**24. A thin flat circular disc of radius 4.5 cm is placed gently over the surface of water. If surface tension of water is  $0.07 \text{ N m}^{-1}$ , then the excess force required to take it away from the surface is:**

- (1) 1.98 mN
  - (2) 99 N
  - (3) 19.8 mN
  - (4) 198 N
- 

**25. A tightly wound 100 turns coil of radius 10 cm carries a current of 7 A. The magnitude of the magnetic field at the centre of the coil is (Take permeability of free space as  $4\pi \times 10^{-7} \text{ SI units}$ ):**

- (1) 4.4 mT
  - (2) 44 T
  - (3) 44 mT
  - (4) 4.4 T
- 

**26. Given below are two statements:**

**Statement I:** Atoms are electrically neutral as they contain equal number of positive and negative charges.

**Statement II:** Atoms of each element are stable and emit their characteristic spectrum.

In the light of the above statements, choose the most appropriate answer from the options given below.

- (1) Statement I is correct but Statement II is incorrect
- (2) Statement I is incorrect but Statement II is correct
- (3) Both Statement I and Statement II are correct
- (4) Both Statement I and Statement II are incorrect

27. The moment of inertia of a thin rod about an axis passing through its mid-point and perpendicular to the rod is  $2400 \text{ g cm}^2$ . The length of the 400 g rod is nearly:

- (1) 20.7 cm
- (2) 72.0 cm
- (3) 8.5 cm
- (4) 17.5 cm

28. In the above diagram, a strong bar magnet is moving towards solenoid-2 from solenoid-1. The direction of induced current in solenoid-1 and that in solenoid-2, respectively, are through the directions:

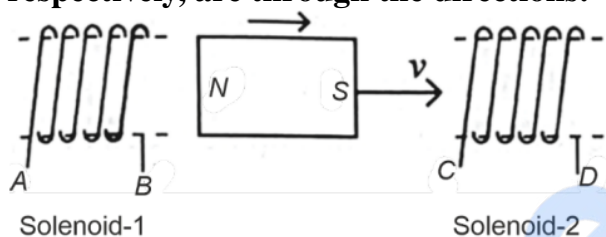

- (1) AB and CD
- (2) BA and DC
- (3) AB and DC
- (4) BA and CD

29. In the nuclear emission stated below, the mass number and atomic number of the product  $Q$  respectively, are:

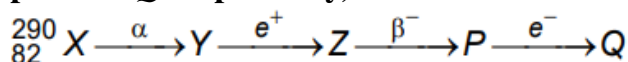

- (1) 288, 82
- (2) 286, 81
- (3) 280, 81
- (4) 286, 80

30. The mass of a planet is  $\frac{1}{10}$  that of the Earth and its diameter is half that of the Earth. The acceleration due to gravity on that planet is:

- (1)  $4.9 \text{ m s}^{-2}$
- (2)  $3.92 \text{ m s}^{-2}$
- (3)  $19.6 \text{ m s}^{-2}$
- (4)  $9.8 \text{ m s}^{-2}$

31. The maximum elongation of a steel wire of 1 m length if the elastic limit of steel and its Young's modulus, respectively, are  $8 \times 10^8 \text{ N/m}^2$  and  $2 \times 10^{11} \text{ N/m}^2$ , is:

- (1) 40 mm
- (2) 8 mm
- (3) 4 mm
- (4) 0.4 mm

32. Match List-I with List-II.

List-I (Material)		List-II (Susceptibility $\chi$ )	
A.	Diamagnetic	I.	$\chi = 0$
B.	Ferromagnetic	II.	$0 > \chi > -1$
C.	Paramagnetic	III.	$\chi \gg 1$
D.	Non-magnetic	IV.	$0 < \chi < \varepsilon$ (a small positive number)

Choose the correct answer from the options given below:

- (1) A-III, B-II, C-I, D-IV
- (2) A-IV, B-III, C-II, D-I
- (3) A-II, B-III, C-IV, D-I
- (4) A-II, B-I, C-III, D-IV

33. A logic circuit provides the output  $Y$  as per the following truth table:

A	B	Y
0	0	1
0	1	0
1	0	1
1	1	0

The expression for the output  $Y$  is:

- (1)  $\bar{B}$
- (2)  $B$
- (3)  $A\bar{B} + \bar{A}$
- (4)  $A\bar{B} + \bar{A}$

34. The graph which shows the variation of  $\frac{1}{\lambda^2}$  and its kinetic energy,  $E$ , is (where  $\lambda$  is de Broglie wavelength of a free particle):

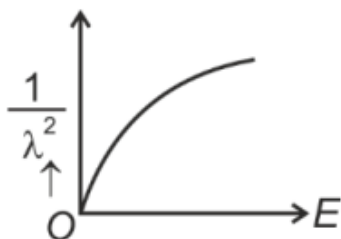

- (1)

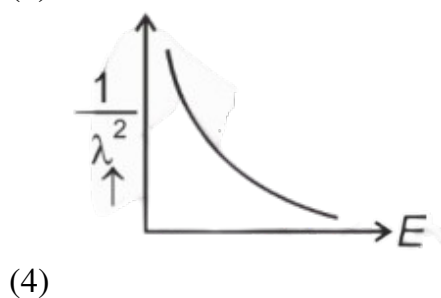
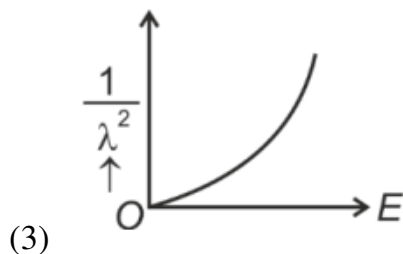
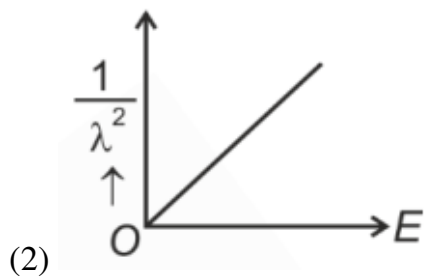

---

**35. A wire of length  $l$  and resistance  $100 \Omega$  is divided into 10 equal parts. The first 5 parts are connected in series, while the next 5 parts are connected in parallel. The two combinations are again connected in series. The resistance of this final combination is:**

- (1)  $55\Omega$   
 (2)  $60\Omega$   
 (3)  $26\Omega$   
 (4)  $52\Omega$
- 

### SECTION-B

**36. If the mass of the bob in a simple pendulum is increased to thrice its original mass and its length is made half its original length, then the new time period of oscillation is  $\frac{x}{2}$  times its original time period. The value of  $x$  is:**

- (1)  $2\sqrt{3}$   
 (2) 4  
 (3)  $\sqrt{3}$   
 (4)  $\sqrt{2}$
- 

**37. A force defined by  $F = \alpha t^2 + \beta t$  acts on a particle at a given time  $t$ . The factor which is dimensionless, if  $\alpha$  and  $\beta$  are constants, is:**

- (1)  $\alpha\beta t$   
 (2)  $\frac{\alpha\beta}{t}$

- (3)  $\frac{\beta t}{\alpha}$   
(4)  $\frac{\alpha t}{\beta}$
- 

**38. An iron bar of length  $L$  has magnetic moment  $M$ . It is bent at the middle of its length such that the two arms make an angle  $60^\circ$  with each other. The magnetic moment of this new magnet is:**

- (1)  $2M$   
(2)  $\frac{M}{\sqrt{3}}$   
(3)  $M$   
(4)  $\frac{M}{2}$
- 

**39. If the plates of a parallel plate capacitor connected to a battery are moved close to each other, then:**

- (A) The charge stored in it increases.  
(B) The energy stored in it decreases.  
(C) Its capacitance increases.  
(D) The ratio of charge to its potential remains the same.  
(E) The product of charge and voltage increases.

**Choose the most appropriate answer:**

- (1) B, D and E only  
(2) A, B and C only  
(3) A, B and E only  
(4) A, C and E only
- 

**40. A small telescope has an objective of focal length 140 cm and an eye piece of focal length 5.0 cm. The magnifying power of telescope for viewing a distant object is:**

- (1) 17  
(2) 32  
(3) 34  
(4) 28
- 

**41. Two heaters A and B have power ratings of 1 kW and 2 kW, respectively. Those two are first connected in series and then in parallel to a fixed power source. The ratio of power outputs for these two cases is:**

- (1) 1 : 2  
(2) 2 : 3  
(3) 1 : 1  
(4) 2 : 9
- 

**42. A metallic bar of Young's modulus  $0.5 \times 10^{11} \text{ N m}^{-2}$  and coefficient of linear thermal expansion  $10^{-5} \text{ }^\circ\text{C}^{-1}$ , length 1 m and area of cross-section  $10^{-3} \text{ m}^2$  is heated from  $0^\circ\text{C}$  to  $100^\circ\text{C}$  without expansion or bending. The compressive force developed in it is:**

- (1)  $100 \times 10^3 \text{ N}$

- (2)  $2 \times 10^3$  N  
 (3)  $5 \times 10^3$  N  
 (4)  $50 \times 10^3$  N

**43. A parallel plate capacitor is charged by connecting it to a battery through a resistor. If  $I$  is the current in the circuit, then in the gap between the plates:**

- (1) Displacement current of magnitude equal to  $I$  flows in a direction opposite to that of  $I$ .  
 (2) Displacement current of magnitude greater than  $I$  flows but can be in any direction.  
 (3) There is no current.  
 (4) Displacement current of magnitude equal to  $I$  flows in the same direction as  $I$ .

**44. Choose the correct circuit which can achieve the bridge balance.**

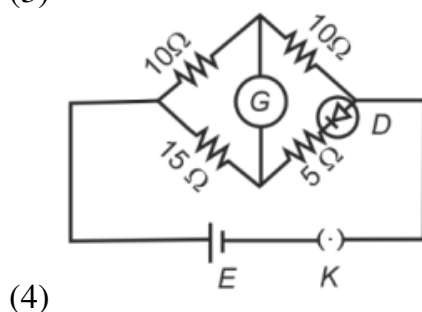
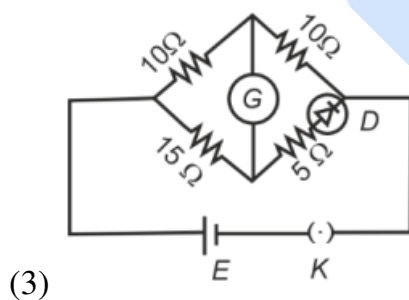
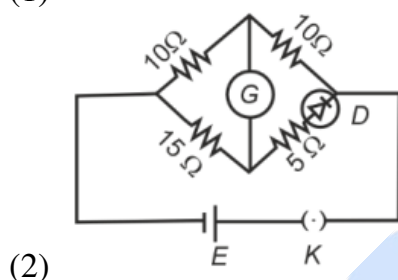
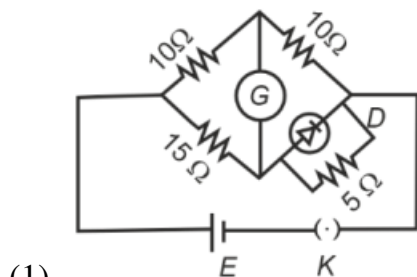

**45. The minimum energy required to launch a satellite of mass  $m$  from the surface of Earth of mass  $M$  and radius  $R$  in a circular orbit at an altitude of  $2R$  from the surface**

of the Earth is:

- (1)  $\frac{GmM}{2R}$
- (2)  $\frac{GmM}{3R}$
- (3)  $\frac{5GmM}{6R}$
- (4)  $\frac{2GmM}{3R}$

46. The property which is not of an electromagnetic wave travelling in free space is that:

- (1) They travel with a speed equal to  $\frac{1}{\sqrt{\mu_0 \epsilon_0}}$ .
- (2) They originate from charges moving with uniform speed.
- (3) They are transverse in nature.
- (4) The energy density in electric field is equal to energy density in magnetic field.

47. The following graph represents the  $T$ - $V$  curves of an ideal gas (where  $T$  is the temperature and  $V$  the volume) at three pressures  $P_1$ ,  $P_2$  and  $P_3$ , compared with those of Charles's law represented as dotted lines.

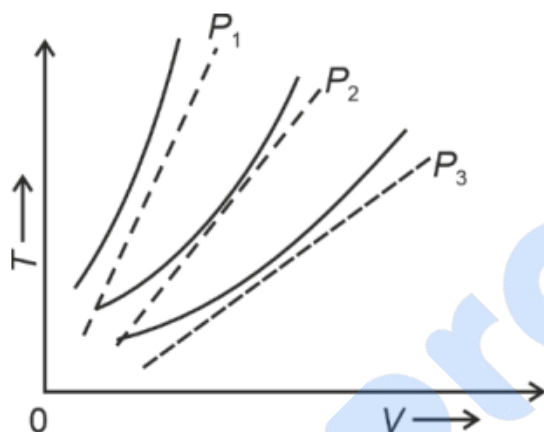

Then the correct relation is:

- (1)  $P_2 > P_1 > P_3$
- (2)  $P_1 > P_2 > P_3$
- (3)  $P_3 > P_2 > P_1$
- (4)  $P_1 > P_3 > P_2$

48. A sheet is placed on a horizontal surface in front of a strong magnetic pole. A force is needed to:

- A. hold the sheet there if it is magnetic.
- B. hold the sheet there if it is non-magnetic.
- C. move the sheet away from the pole with uniform velocity if it is conducting.
- D. move the sheet away from the pole with uniform velocity if it is both, non-conducting and non-polar.

Choose the correct statement(s) from the options given below:

- (1) A, C, and D only
- (2) C only
- (3) B and D only

(4) A and C only

49. The velocity ( $v$ ) – time ( $t$ ) plot of the motion of a body is shown below.

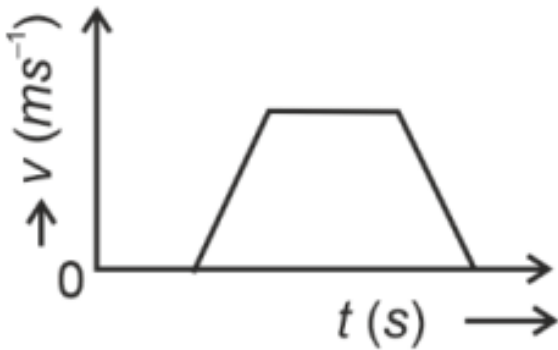

The acceleration ( $a$ ) – time ( $t$ ) graph that best suits this motion is:

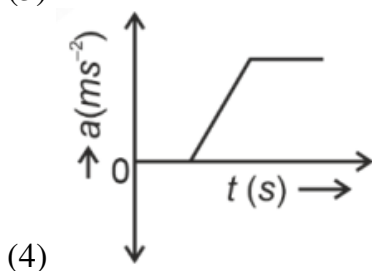
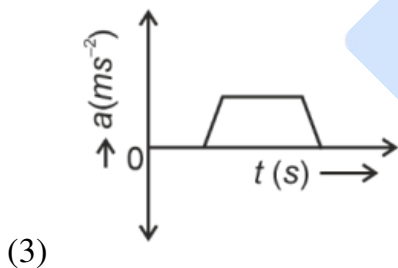
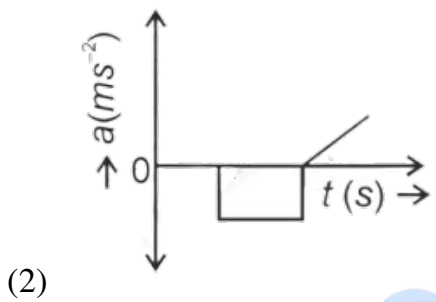
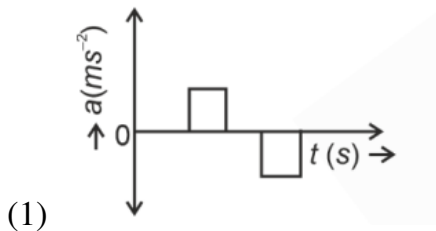

50. A  $10 \mu F$  capacitor is connected to a  $210 \text{ V}$ ,  $50 \text{ Hz}$  source as shown in figure. The peak current in the circuit is nearly ( $\pi = 3.14$ ):

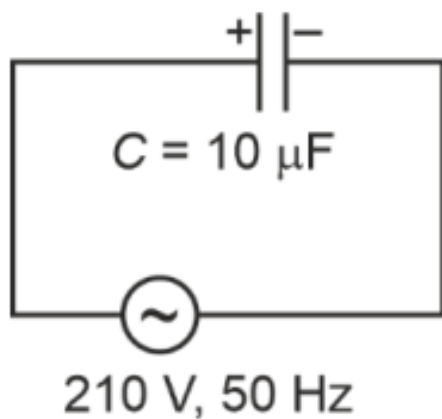

- (1) 1.20 A
- (2) 0.35 A
- (3) 0.58 A
- (4) 0.93 A

## CHEMISTRY

### SECTION-B

**51. A compound with a molecular formula of  $C_6H_{14}$  has two tertiary carbons. Its IUPAC name is:**

- (1) 2,3-dimethylbutane
- (2) 2,2-dimethylbutane
- (3) n-hexane
- (4) 2-methylpentane

**52. Given below are two statements:**

**Statement I:** Both  $[\text{Co}(\text{NH}_3)_6]^{3+}$  and  $[\text{CoF}_6]^{3-}$  complexes are octahedral but differ in their magnetic behavior.

**Statement II:**  $[\text{Co}(\text{NH}_3)_6]^{3+}$  is diamagnetic whereas  $[\text{CoF}_6]^{3-}$  is paramagnetic.

Choose the correct answer from the options given below:

- (1) Statement I is true but Statement II is false
- (2) Statement I is false but Statement II is true
- (3) Both Statement I and Statement II are true
- (4) Both Statement I and Statement II are false

**53. Match List I with List II.**

List-I (Process)		List-II (Conditions)	
A.	Isothermal process	I.	No heat exchange
B.	Isochoric process	II.	Carried out at constant temperature
C.	Isobaric process	III.	Carried out at constant volume
D.	Adiabatic process	IV.	Carried out at constant pressure

Choose the correct answer from the options given below:

- (1) A-I, B-II, C-III, D-IV
- (2) A-II, B-III, C-IV, D-I
- (3) A-IV, B-III, C-II, D-I
- (4) A-V, B-III, C-II, D-I

**54. Match List I with List II.**

List I (Molecule)		List II (Number and types of bonds between two carbon atoms)	
A.	ethane	I.	one $\sigma$ -bond and two $\pi$ -bonds
B.	ethene	II.	two $\pi$ -bonds
C.	carbon molecule, $C_2$	III.	one $\sigma$ -bond
D.	ethyne	IV.	one $\sigma$ -bond and one $\pi$ -bond

Choose the correct answer from the options given below:

- (1) A-III, B-IV, C-II, D-I
- (2) A-III, B-IV, C-I, D-II
- (3) A-I, B-IV, C-II, D-III
- (4) A-IV, B-III, C-II, D-I

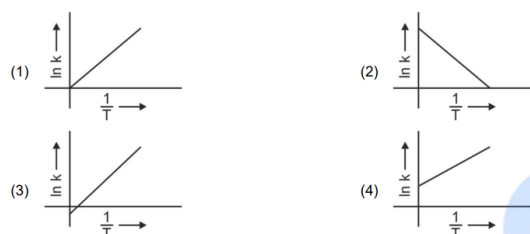
**55. Which plot of  $\ln k$  vs  $\frac{1}{T}$  is consistent with Arrhenius equation?**

**56. Match List I with List II.**

List I (Quantum Number)		List II (Information provided)	
A.	$m_l$	I.	Shape of orbital
B.	$m_s$	II.	Size of orbital
C.	$l$	III.	Orientation of orbital
D.	$n$	IV.	Orientation of spin of electron

Choose the correct answer from the options given below:

- (1) A-III, B-IV, C-I, D-II
- (2) A-II, B-I, C-IV, D-III
- (3) A-I, B-III, C-II, D-IV
- (4) A-III, B-IV, C-I, D-II

**57. The energy of an electron in the ground state ( $n = 1$ ) for  $He^+$  ion is  $-x$  J, then that for an electron in  $n = 2$  state for  $Be^{3+}$  ion in J is**

- (1)  $-4x$
- (2)  $-\frac{4}{9}x$
- (3)  $-x$
- (4)  $-\frac{x}{9}$

58. The compound that will undergo  $S_N1$  reaction with the fastest rate is

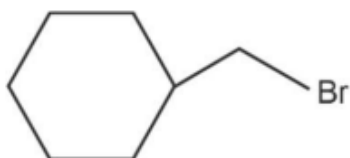
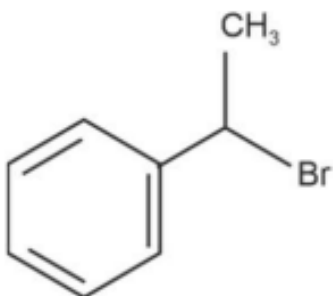
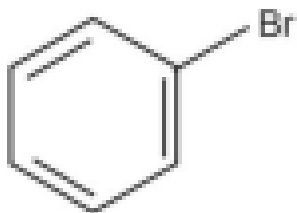

59.

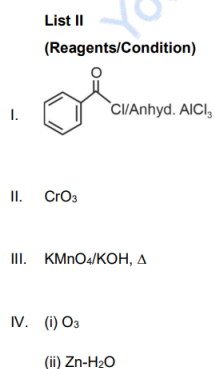
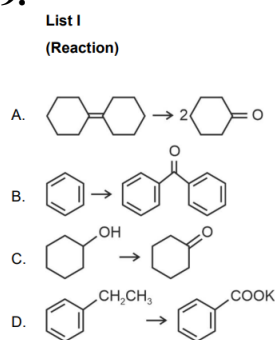

Choose the correct answer from the options given below: **Match List I with List II.**

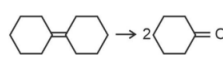
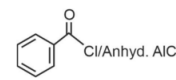
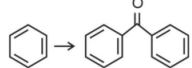
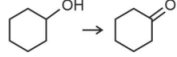
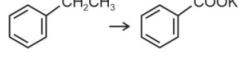
List I (Reaction)	List II (Reagents/Condition)
A. 	I. 
B. 	II. CrO <sub>3</sub>
C. 	III. KMnO <sub>4</sub> /KOH, Δ
D. 	IV. (i) O <sub>3</sub> (ii) Zn-H <sub>2</sub> O

Choose the correct answer from the options given below:

(A) A-IV, B-I, C-II, D-III (B) A-I, B-IV, C-II, D-III (C) A-IV, B-I, C-III, D-II (D) A-III, B-I, C-II, D-IV

60. Match List I with List II.

List I (Compound)		List II (Shape/geometry)	
A.	NH <sub>3</sub>	I.	Trigonal Pyramidal
B.	BrF <sub>5</sub>	II.	Square Planar
C.	XeF <sub>4</sub>	III.	Octahedral
D.	SF <sub>6</sub>	IV.	Square Pyramidal

Choose the correct answer from the options given below:

- (1) A-II, B-III, C-IV, D-I  
 (2) A-I, B-III, C-IV, D-I  
 (3) A-I, B-IV, C-II, D-III  
 (4) A-II, B-IV, C-III, D-I

61. In which of the following processes does entropy increase?

- A. A liquid evaporates to vapor.  
 B. Temperature of a crystalline solid lowered from 130 K to 0 K.  
 C.  $2NaHCO_3(s) \rightarrow Na_2CO_3(s) + CO_2(g) + H_2O(g)$   
 D.  $Cl_2(g) \rightarrow 2Cl(g)$

Choose the correct answer from the options given below:

(A) A, C and D (B) C and D (C) A and C (D) A, B and D

Choose the correct answer from the options given below:

62. Fehling's solution 'A' is

- (1) alkaline solution of sodium potassium tartrate (Rochelle's salt)  
 (2) aqueous sodium citrate  
 (3) aqueous copper sulphate  
 (4) alkaline copper sulphate

63. Which one of the following alcohols reacts instantaneously with Lucas reagent?

- (1)  $\text{CH}_3 - \underset{\text{CH}_3}{\text{CH}} - \text{CH}_2\text{OH}$
- (1)  $\text{CH}_3 - \underset{\text{CH}_3}{\overset{\text{CH}_3}{\text{C}}} - \text{OH}$
- (2)  $\text{CH}_3 - \text{CH}_2 - \text{CH}_2 - \text{CH}_2\text{OH}$
- (3)  $\text{CH}_3 - \text{CH}_2 - \underset{\text{CH}_3}{\text{CH}} - \text{OH}$
- (4)

64. For the reaction  $2A \leftrightarrow B + C$ ,  $K_c = 4 \times 10^{-3}$ . At a given time, the composition of reaction mixture is:  $[A] = [B] = [C] = 2 \times 10^{-3} M$ . Then, which of the following is correct?

- (1) Reaction has a tendency to go in backward direction.
- (2) Reaction has gone to completion in forward direction.
- (3) Reaction is at equilibrium.
- (4) Reaction has a tendency to go in forward direction.

65. 1 gram of sodium hydroxide was treated with 25 mL of 0.75 M HCl solution, the mass of sodium hydroxide left unreacted is equal to

- (1) Zero mg
- (2) 200 mg
- (3) 75 mg
- (4) 250 mg

66. Intramolecular hydrogen bonding is present in

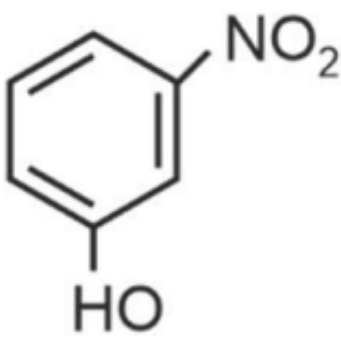
- (1) 

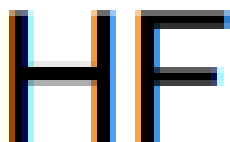

(2)

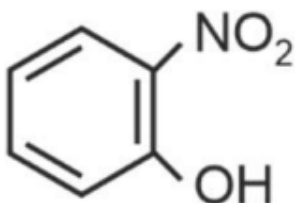

(3)

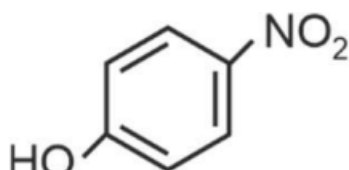

(4)

67. 'Spin only' magnetic moment is same for which of the following ions?

- A.  $Tl^{3+}$
- B.  $Cr^{2+}$
- C.  $Mn^{2+}$
- D.  $Fe^{2+}$
- E.  $Sc^{3+}$

Choose the most appropriate answer from the options given below.

- (1) B and C only
- (2) A and D only
- (3) B and D only
- (4) A and E only

68. The reagents with which glucose does not react to give the corresponding tests/products are

- A. Tollen's reagent
- B. Schiff's reagent
- C. HCN
- D.  $NH_2OH$
- E.  $NaHSO_3$

Choose the correct options from the given below:

- (1.) B and E
- (2.) E and D
- (3.) B and C
- (4.) A and D

69. Identify the correct reagents that would bring about the following transformation: from an alkene to an aldehyde.

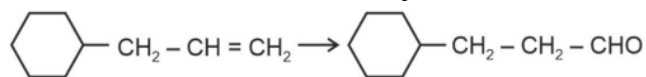

(A)

(B)  $\text{BH}_3$  (C)  $\text{H}_2\text{O}_2 / \text{OH}^-$  (D) alk.  $\text{KMnO}_4$  (E)  $\text{H}_3\text{O}^+$  (A)  $\text{H}_2\text{O} / \text{H}^+$  (B) PCC (A)  $\text{H}_2\text{O} / \text{H}^+$  (B)  $\text{CrO}_3$  (A)  $\text{BH}_3$  (B)  $\text{H}_2\text{O}_2 / \text{OH}^-$  (C) PCC

70. Activation energy of any chemical reaction can be calculated if one knows the value of

- (1) orientation of reactant molecules during collision
- (2) rate constant at two different temperatures
- (3) rate constant at standard temperature
- (4) probability of collision

71. Arrange the following elements in increasing order of first ionization enthalpy: Li, Be, B, C, N

- (1)  $\text{Li} < \text{Be} < \text{C} < \text{B} < \text{N}$
- (2)  $\text{Li} < \text{Be} < \text{N} < \text{B} < \text{C}$
- (3)  $\text{Li} < \text{Be} < \text{B} < \text{C} < \text{N}$
- (4)  $\text{Li} < \text{B} < \text{Be} < \text{C} < \text{N}$

72. Among Group 16 elements, which one does NOT show -2 oxidation state?

- (1) Te
- (2) Po
- (3) O
- (4) Se

73. Which reaction is NOT a redox reaction?

- (1)  $\text{H}_2 + \text{Cl}_2 \rightarrow 2\text{HCl}$
- (2)  $\text{BaCl}_2 + \text{Na}_2\text{SO}_4 \rightarrow \text{BaSO}_4 + 2\text{NaCl}$
- (3)  $\text{Zn} + \text{CuSO}_4 \rightarrow \text{ZnSO}_4 + \text{Cu}$
- (4)  $2\text{KClO}_3 \rightarrow 2\text{KCl} + 3\text{O}_2$

74. In which of the following equilibria,  $K_p$  and  $K_c$  are NOT equal?

- (1)  $\text{CO}_{(g)} + \text{H}_2\text{O}_{(g)} \rightleftharpoons \text{CO}_{2(g)} + \text{H}_2_{(g)}$
- (2)  $2\text{BrCl}_{(g)} \rightleftharpoons \text{Br}_{2(g)} + \text{Cl}_{2(g)}$
- (3)  $\text{PCl}_{5(g)} \rightleftharpoons \text{PCl}_{3(g)} + \text{Cl}_{2(g)}$
- (4)  $\text{H}_{2(g)} + \text{I}_{2(g)} \rightleftharpoons 2\text{HI}_{(g)}$

---

75. The Henry's law constant ( $K_H$ ) values of three gases (A, B, C) in water are 145,  $2 \times 10^{-5}$ , and 35 kbar, respectively. The solubility of these gases in water follow the order:

- (1)  $A > C > B$
  - (2)  $A > B > C$
  - (3)  $B > A > C$
  - (4)  $B > C > A$
- 

76. Given below are two statements:

**Statement I:** The boiling point of three isomeric pentanes follows the order n-pentane > isopentane > neopentane.

**Statement II:** When branching increases, the molecule attains a shape of sphere. This results in smaller surface area for contact, due to which the intermolecular forces between the spherical molecules are weak, thereby lowering the boiling point.

In the light of the above statements, choose the most appropriate answer from the options given below:

- (1) Statement I is correct but Statement II is incorrect
  - (2) Statement I is incorrect but Statement II is correct
  - (3) Both Statement I and Statement II are correct
  - (4) Both Statement I and Statement II are incorrect
- 

77. Given below are two statements:

**Statement I:** Aniline does not undergo Friedel-Crafts alkylation reaction.

**Statement II:** Aniline cannot be prepared through Gabriel synthesis.

In the light of the above statements, choose the most appropriate answer from the options given below:

- (1) Statement I is correct but Statement II is false
  - (2) Statement I is incorrect but Statement II is true
  - (3) Both statement I and Statement II are true
  - (4) Both Statement I and Statement II are false
- 

78. The highest number of helium atoms is in

- (1) 4 g of helium
  - (2) 2.71098 L of helium at STP
  - (3) 4 mol of helium
  - (4) 4 u of helium
- 

79. Arrange the following elements in increasing order of electronegativity: N, O, F, C, Si

- (1)  $O < F < N < C < Si$
- (2)  $F < O < N < C < Si$
- (3)  $Si < C < N < O < F$

(4)  $\text{Si} < \text{C} < \text{O} < \text{N} < \text{F}$

---

80. The most stable carbocation among the following is:

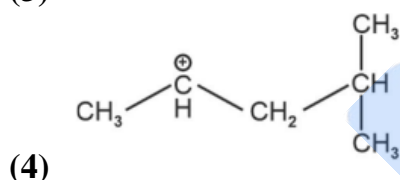
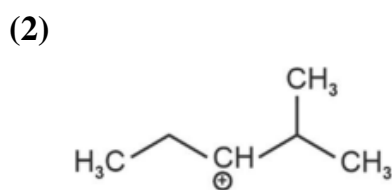
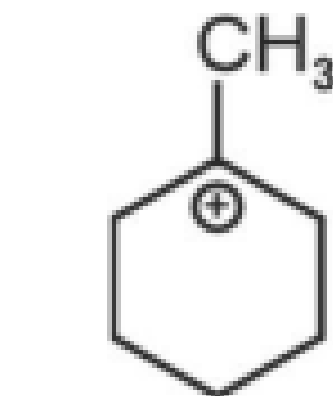
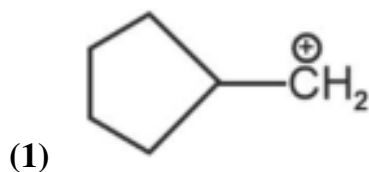

81. Given below are two statements:

**Statement I:** The boiling point of hydrides of Group 16 elements follow the order  $\text{H}_2\text{O} > \text{H}_2\text{Te} > \text{H}_2\text{Se} > \text{H}_2\text{S}$ .

**Statement II:** On the basis of molecular mass,  $\text{H}_2\text{O}$  is expected to have lower boiling point than the other members of the group but due to the presence of extensive H-bonding in  $\text{H}_2\text{O}$ , it has higher boiling point.

In the light of the above statements, choose the correct answer from the options given below:

- (1) Statement I is true but Statement II is false
  - (2) Statement I is false but Statement II is true
  - (3) Both Statement I and Statement II are true
  - (4) Both Statement I and Statement II are false
- 

82. Match List I with List II.

Choose the correct answer from the options given below:

List I (Complex)	List II (Type of isomerism)
A. $[\text{Co}(\text{NH}_3)_5(\text{NO}_2)]\text{Cl}_2$	I. Solvate isomerism
B. $[\text{Co}(\text{NH}_3)_5(\text{SO}_4)]\text{Br}$	II. Linkage isomerism
C. $[\text{Co}(\text{NH}_3)_6][\text{Cr}(\text{CN})_6]$	III. Ionization isomerism
D. $[\text{Co}(\text{H}_2\text{O})_6]\text{Cl}_3$	IV. Coordination isomerism

(A) A-I, B-IV, C-III, D-II (B) A-II, B-IV, C-III, D-I (C) A-II, B-III, C-IV, D-I (D) A-I, B-III, C-IV, D-II

83. On heating, some solid substances change from solid to vapor state without passing through liquid state. The technique used for the purification of such solid substances based on the above principle is known as

- (1) Distillation
- (2) Chromatography
- (3) Crystallization
- (4) Sublimation

84. The  $E^\circ$  value for the  $\text{Mn}^{3+}/\text{Mn}^{2+}$  couple is more positive than that of  $\text{Cr}^{3+}/\text{Cr}^{2+}$  or  $\text{Fe}^{3+}/\text{Fe}^{2+}$  due to change of

- (1)  $d^4$  to  $d^5$  configuration
- (2)  $d^3$  to  $d^5$  configuration
- (3)  $d^5$  to  $d^4$  configuration
- (4)  $d^5$  to  $d^2$  configuration

85. Match List I with List II.

List I (Conversion)	List II (Number of Faraday required)
A. 1 mol of $\text{H}_2\text{O}$ to $\text{O}_2$	I. 3F
B. 1 mol of $\text{MnO}_4^-$ to $\text{Mn}^{2+}$	II. 2F
C. 1.5 mol of Ca from molten $\text{CaCl}_2$	III. 1F
D. 1 mol of $\text{FeO}$ to $\text{Fe}_2\text{O}_3$	IV. 5F

- (1) A-II, B-III, C-I, D-IV
- (2) A-III, B-IV, C-II, D-I
- (3) A-II, B-IV, C-I, D-III
- (4) A-III, B-IV, C-I, D-II

### 3. SECTION-B

86. The products A and B obtained in the following reactions, respectively, are

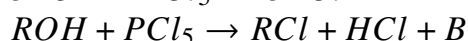
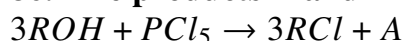

- (1)  $\text{H}_3\text{PO}_4$  and  $\text{POCl}_3$
- (2)  $\text{H}_3\text{PO}_3$  and  $\text{POCl}_3$
- (3)  $\text{POCl}_3$  and  $\text{H}_3\text{PO}_3$
- (4)  $\text{POCl}_3$  and  $\text{H}_3\text{PO}_4$

---

87. Identify the correct answer.

- (1) Dipole moment of  $NF_3$  is greater than that of  $NH_3$
  - (2) Three canonical forms can be drawn for  $CO_3^{2-}$  ion
  - (3) Three resonance structures can be drawn for ozone
  - (4)  $BF_3$  has non-zero dipole moment
- 

88. The rate of a reaction quadruples when temperature changes from  $27^\circ C$  to  $57^\circ C$ . Calculate the energy of activation.

Given  $R = 8.314 J \cdot K^{-1} \cdot mol^{-1}$ ,  $\log(4) = 0.6021$

- (1) 38.0 kJ/mol
  - (2) 3804 kJ/mol
  - (3) 38.04 kJ/mol
  - (4) 380.4 kJ/mol
- 

89. Given below are certain cations. Using inorganic qualitative analysis, arrange them in increasing group number from 0 to VI.

- A.  $Al^{3+}$
- B.  $Cu^{2+}$
- C.  $Ba^{2+}$
- D.  $Co^{2+}$
- E.  $Mg^{2+}$

- (1) E, C, D, B, A
  - (2) E, A, B, C, D
  - (3) B, A, D, C, E
  - (4) B, C, A, D, E
- 

90. The plot of osmotic pressure ( $\Pi$ ) vs concentration ( $mol L^{-1}$ ) for a solution gives a straight line with slope  $25.73 bar mol^{-1}$ . The temperature at which the osmotic pressure measurement is done is

Given  $R = 0.083 L bar mol^{-1} K^{-1}$

- (1)  $275.3^\circ C$
  - (2)  $120.05^\circ C$
  - (3)  $37^\circ C$
  - (4)  $310^\circ C$
- 

91. The work done during reversible isothermal expansion of one mole of hydrogen gas at  $25^\circ C$  from pressure of 20 atmospheres to 10 atmospheres is

Given  $R = 2.0 cal K^{-1} mol^{-1}$

- (1) 14.13 calories
- (2) 100 calories
- (3) 0 calorie
- (4) -413.14 calories

92. A compound X contains 32% of A, 20% of B and remaining percentage of C. Then, the empirical formula of X is:

Given atomic masses of A = 64; B = 40; C = 32

- (1)  $AB_2C_2$
- (2)  $ABC_4$
- (3)  $AB_2C$
- (4)  $AB_3C$

93. During the preparation of Mohr's salt solution (Ferrous ammonium sulphate), which of the following acid is added to prevent hydrolysis of  $Fe^{2+}$  ion?

- (1) Dilute nitric acid
- (2) Dilute sulphuric acid
- (3) Dilute hydrochloric acid
- (4) Concentrated sulphuric acid

94. The pair of lanthanoid ions which are diamagnetic is

- (1)  $Gd^{3+}$  and  $Eu^{3+}$
- (2)  $Pm^{3+}$  and  $Sm^{3+}$
- (3)  $Ce^{4+}$  and  $Yb^{2+}$
- (4)  $Ce^{3+}$  and  $Eu^{2+}$

95. Consider the following reaction in a sealed vessel at equilibrium with concentrations of

$$N_2 = 3.0 \times 10^{-3} M, \quad O_2 = 4.2 \times 10^{-3} M, \quad NO = 2.8 \times 10^{-3} M$$

.



if  $0.1 \text{ mol L}^{-1}$  of  $NO(g)$  is taken in a closed vessel, what will be the degree of dissociation ( $\alpha$ ) of  $NO$  at equilibrium?

- (1) 0.8889
- (2) 0.717
- (3) 0.00889
- (4) 0.0889

96. Given below are two statements:

Statement I:  $[Co(NH_3)_6]^{3+}$  is a homoleptic complex whereas  $[Co(NH_3)_4Cl_2]^+$  is a heteroleptic complex.

Statement II: Complex  $[Co(NH_3)_6]^{3+}$  has only one kind of ligands but  $[Co(NH_3)_4Cl_2]^+$  has more than one kind of ligands.

In the light of the above statements, choose the correct answer from the options given below.

- (1) Statement I is true but Statement II is false

- (2) Statement I is false but Statement II is true  
 (3) Both Statement I and Statement II are true  
 (4) Both Statement I and Statement II are false

97. For the given reaction:

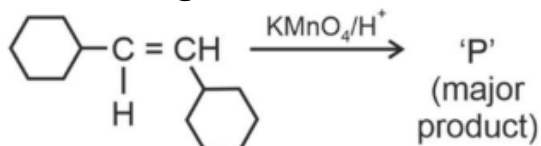

identify the major product *P*.

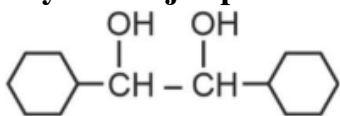
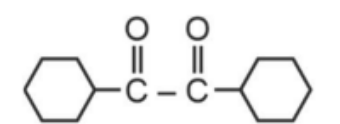
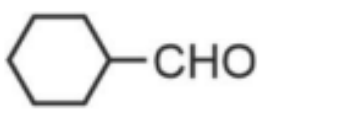
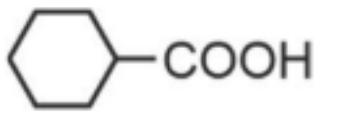
- (1) 
- (2) 
- (3) 
- (4) 

98. Major products A and B formed in the following reaction sequence are:

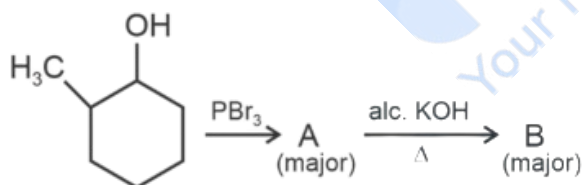

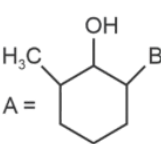
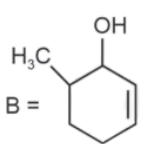
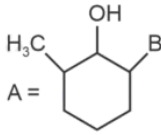
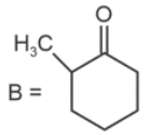
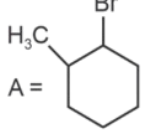
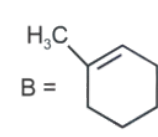
- (1) A =  ; B = 
- (2) A =  ; B = 
- (3) A =  ; B = 

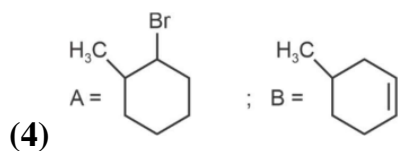

99. Identify the major product C formed in the following reaction sequence:

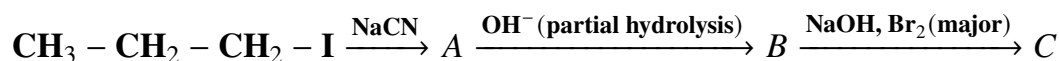

- (1) Butanamide
- (2)  $\alpha$ -Bromobutanoic acid
- (3) Propylamine
- (4) Butylamine

100. Mass in grams of copper deposited by passing 9.6487 A current through a voltmeter containing copper sulphate solution for 100 seconds is (Given: Molar mass of Cu = 63 g mol<sup>-1</sup>, 1 F = 96487 C)

- (1) 31.5 g
- (2) 0.0315 g
- (3) 3.15 g
- (4) 0.315 g

## BOTANY

### SECTION-A

101. The lactose present in the growth medium of bacteria is transported to the cell by the action of

- (1) Permease
- (2) Polymerase
- (3) Beta-galactosidase
- (4) Acetylase

102. Identify the type of flowers based on the position of calyx, corolla and androecium with respect to the ovary from the given figures (a) and (b)

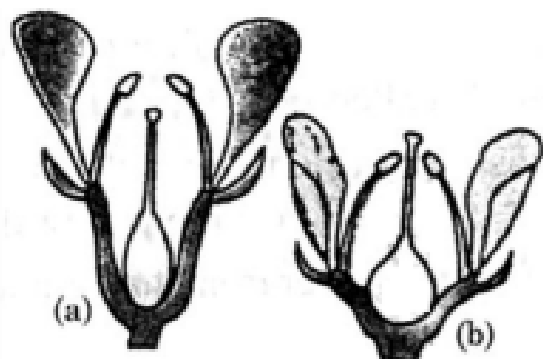

- (1) (a) Peryginous; (b) Epigynous
  - (2) (a) Peryginous; (b) Peryginous
  - (3) (a) Epigynous; (b) Hypogynous
  - (4) (a) Hypogynous; (b) Epigynous
- 

**103. The type of conservation in which the threatened species are taken out from their natural habitat and placed in special setting where they can be protected and given special care is called**

- (1) Semi-conservative method
  - (2) Sustainable development
  - (3) In-situ conservation
  - (4) Biodiversity conservation
- 

**104. Formation of interfascicular cambium from fully developed parenchyma cells is an example for**

- (1) Dedifferentiation
  - (2) Maturation
  - (3) Differentiation
  - (4) Redifferentiation
- 

**105. Which of the following is an example of actinomorphic flower?**

- (1) Pisum
  - (2) Sesbania
  - (3) Datura
  - (4) Cassia
- 

**106. Hind III always cuts DNA molecules at a particular point called recognition sequence and it consists of:**

- (1) 4 bp
  - (2) 10 bp
  - (3) 8 bp
  - (4) 6 bp
- 

**107. Which of the following are required for the dark reaction of photosynthesis?**

- A. Light
- B. Chlorophyll
- C. CO<sub>2</sub>
- D. ATP
- E. NADPH

**Choose the correct answer from the options given below:**

- (1) C, D and E only
- (2) D and E only
- (3) A, B and C only

(4) B, C and D only

**108. Match List I with List II.**

List-I		List-II	
A.	Rhizopus	I.	Mushroom
B.	Ustilago	II.	Smut fungus
C.	Puccinia	III.	Bread mould
D.	Agaricus	IV.	Rust fungus

Choose the correct answer from the options given below:

- (1) A-III, B-II, C-IV, D-I
- (2) A-IV, B-III, C-II, D-I
- (3) A-III, B-II, C-IV, D-I
- (4) A-I, B-III, C-II, D-IV

**109. Lecithin, a small molecular weight organic compound found in living tissues, is an example of:**

- (1) Glycerides
- (2) Carbohydrates
- (3) Amino acids
- (4) Phospholipids

**110. The capacity to generate a whole plant from any cell of the plant is called:**

- (1) Differentiation
- (2) Somatic hybridization
- (3) Totipotency
- (4) Micropropagation

**111. Given below are two statements:**

**Statement I:** Chromosomes become gradually visible under light microscope during leptotene stage.

**Statement II:** The beginning of diplotene stage is recognized by dissolution of synaptonemal complex.

In the light of the above statements, choose the correct answer from the options given below:

- (1) Statement I is true but Statement II is false
- (2) Statement I is false but Statement II is true
- (3) Both Statement I and Statement II are true
- (4) Both Statement I and Statement II are false

**112. How many molecules of ATP and NADPH are required for every molecule of CO<sub>2</sub> fixed in the Calvin cycle?**

- (1) 3 molecules of ATP and 3 molecules of NADPH
- (2) 3 molecules of ATP and 2 molecules of NADPH

- (3) 2 molecules of ATP and 3 molecules of NADPH  
 (4) 2 molecules of ATP and 2 molecules of NADPH

113. Match List I with List II.

List I		List II	
A.	Two or more alternative forms of a gene	I.	Back cross
B.	Cross of $F_1$ progeny with homozygous recessive parent	II.	Ploidy
C.	Cross of $F_1$ progeny with any of the parents	III.	Allele
D.	Number of chromosome sets in plant	IV.	Test cross

Choose the correct answer from the options given below.

- (1) A-III, B-IV, C-I, D-II  
 (2) A-IV, B-III, C-II, D-I  
 (3) A-III, B-I, C-IV, D-II  
 (4) A-I, B-III, C-II, D-IV

114. List of endangered species was released by

- (1) FOAM  
 (2) IUCN  
 (3) GEAC  
 (4) WWF

115. The equation of Verhulst-Pearl logistic growth is

$$\frac{dN}{dt} = rN \left( \frac{K - N}{K} \right)$$

From this equation,  $K$  indicates:

- (1) Carrying capacity  
 (2) Population density  
 (3) Intrinsic rate of natural increase  
 (4) Biotic potential

116. Identify the set of correct statements:

- A. The flowers of *Vallisneria* are colourful and produce nectar.  
 B. The flowers of water lily are not pollinated by water.  
 C. In most of water-pollinated species, the pollen grains are protected from wetting.  
 D. Pollen grains of some hydrophytes are long and ribbon like.  
 E. In some hydrophytes, the pollen grains are carried passively inside water.

Choose the correct answer from the options given below.

- (1) A, C, D and E only  
 (2) B, C, D and E only  
 (3) C, D and E only

(4) A, B, C and D only

---

117. Bulliform cells are responsible for

- (1) Increased photosynthesis in monocots
  - (2) Providing large spaces for storage of sugars
  - (3) Inward curling of leaves in monocots
  - (4) Protecting the plant from salt stress
- 

118. Which one of the following can be explained on the basis of Mendel's Law of Dominance?

- (1) B, C and D only
  - (2) A, B, C, D and E
  - (3) A, B and C only
  - (4) A, C, D and E only
- 

119. The cofactor of the enzyme carboxypeptidase is:

- (1) Flavin
  - (2) Haem
  - (3) Zinc
  - (4) Niacin
- 

120. Which one of the following is not a criterion for classification of fungi?

- (1) Mode of spore formation
  - (2) Fruiting body
  - (3) Morphology of mycelium
  - (4) Mode of nutrition
- 

121. Match List I with List II.

List-I		List-II	
A.	Nucleolus	I.	Site of formation of glycolipid
B.	Centriole	II.	Organization like the cartwheel
C.	Leucoplasts	III.	Site for active ribosomal RNA synthesis
D.	Golgi apparatus	IV.	For storing nutrients

Choose the correct answer from the options given below:

- (1) A-III, B-IV, C-II, D-I
  - (2) A-II, B-III, C-IV, D-I
  - (3) A-III, B-II, C-IV, D-I
  - (4) A-I, B-III, C-II, D-IV
- 

122. Identify the part of the seed from the given figure which is destined to form root when the seed germinates.

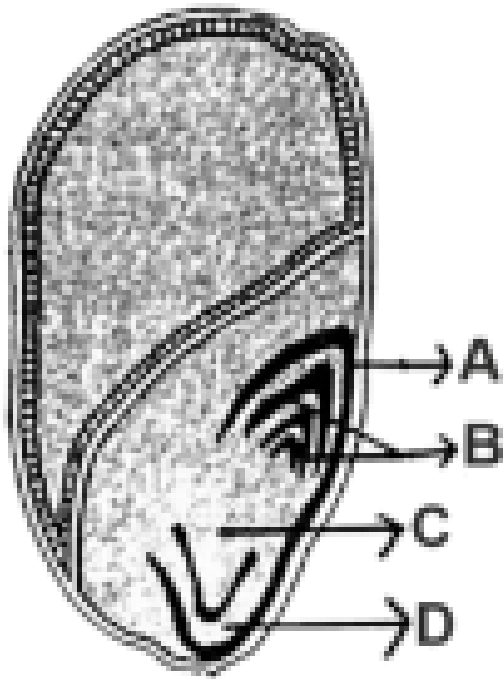

- (1) C
- (2) D
- (3) A
- (4) B

123. In the given figure, which component has thin outer walls and highly thickened inner walls?

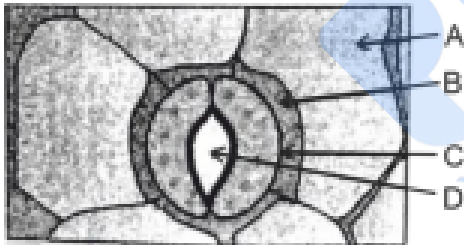

- (1) A
- (2) B
- (3) C
- (4) D

124. A transcription unit in DNA is defined primarily by the three regions in DNA and these are with respect to upstream and down stream end:

- (1) Inducer, Repressor, Structural gene
- (2) Promotor, Structural gene, Terminator
- (3) Repressor, Operator gene, Structural gene
- (4) Structural gene, Transposons, Operator gene

125. Given below are two statements:

**Statement I:** Parenchyma is living but collenchyma is dead tissue.

**Statement II:** Gymnosperms lack xylem vessels but presence of xylem vessels is the characteristic of angiosperms.

In the light of the above statements, choose the correct answer from the options given below:

- (1) Statement I is true but Statement II is false
  - (2) Statement I is false but Statement II is true
  - (3) Both Statement I and Statement II are true
  - (4) Both Statement I and Statement II are false
- 

126. A pink flowered Snapdragon plant was crossed with a red flowered Snapdragon plant. What type of phenotype(s) is/are expected in the progeny?

- (1) Only pink flowered plants
  - (2) Red, Pink as well as white flowered plants
  - (3) Only red flowered plants
  - (4) Red flowered as well as pink flowered plants
- 

127. Inhibition of Succinic dehydrogenase enzyme by malonate is a classical example of:

- (1) Competitive inhibition
  - (2) Enzyme activation
  - (3) Cofactor inhibition
  - (4) Feedback inhibition
- 

128. Match List I with List II.

List I		List II	
A.	<i>Clostridium butylicum</i>	I.	Ethanol
B.	<i>Saccharomyces cerevisiae</i>	II.	Streptokinase
C.	<i>Trichoderma polysporum</i>	III.	Butyric acid
D.	<i>Streptococcus</i> sp.	IV.	Cyclosporin-A

Choose the correct option from the options given below:

- (1) A-III, B-I, C-IV, D-II
  - (2) A-IV, B-II, C-III, D-I
  - (3) A-III, B-I, C-II, D-IV
  - (4) A-II, B-IV, C-III, D-I
- 

129. Spindle fibers attach to kinetochores of chromosomes during

- (1) Anaphase
  - (2) Telophase
  - (3) Prophase
  - (4) Metaphase
- 

130. Auxin is used by gardeners to prepare weed-free lawns. But no damage is caused to grass as auxin

- (1) does not affect mature monocotyledonous plants.
  - (2) can help in cell division in grasses, to produce growth.
  - (3) promotes apical dominance.
  - (4) promotes abscission of mature leaves only.
- 

131. Tropical regions show greatest level of species richness because

- A. Tropical latitudes have remained relatively undisturbed for millions of years, hence more time was available for species diversification.
- B. Tropical environments are more seasonal.
- C. More solar energy is available in tropics.
- D. Constant environments promote niche specialization.
- E. Tropical environments are constant and predictable.

Choose the correct option from the options given below:

- (1) A, B and E only
  - (2) A, B and D only
  - (3) A, C, D and E only
  - (4) A and B only
- 

132. Given below are two statements:

Statement I: Bt toxins are insect group specific and coded by a gene cry IAc.

Statement II: Bt toxin exists as inactive protoxin in *B. thuringiensis*. However, after ingestion by the insect, the inactive protoxin gets converted into active form due to the acidic pH of the insect gut.

In the light of the above statements, choose the correct answer from the options given below:

- (1) Statement I is true but Statement II is false
  - (2) Statement I is false but Statement II is true
  - (3) Both Statement I and Statement II are true
  - (4) Both Statement I and Statement II are false
- 

133. What is the fate of a piece of DNA carrying only gene of interest which is transferred into an alien organism?

- A. The piece of DNA would be able to multiply itself independently in the progeny cells of the organism.
- B. It may get integrated into the genome of the recipient.
- C. It may multiply and be inherited along with the host DNA.
- D. The alien piece of DNA is not an integral part of chromosome.
- E. It shows ability to replicate.

Choose the correct option from the options given below:

- (1) B and C only
- (2) A and E only

- (3) A and B only  
(4) D and E only
- 

134. These are regarded as major causes of biodiversity loss:

- A. Over exploitation
- B. Co-extinction
- C. Mutation
- D. Habitat loss and fragmentation
- E. Migration

Choose the correct option from the options given below:

- (1) A, B and E only
  - (2) A, B and D only
  - (3) A, C and D only
  - (4) A, B, C and D only
- 

135. In a plant, black seed color ( $BB/Bb$ ) is dominant over white seed color ( $bb$ ). In order to find out the genotype of the black seed plant, with which of the following genotype will you cross it?

- (1) Bb
  - (2) BBBb
  - (3) BB
  - (4) bb
- 

#### SECTION-B

136. Read the following statements and choose the set of correct statements:

- A. Asexual reproduction occurs usually by biflagellate zoospores.
- B. Sexual reproduction is by oogamous method only.
- C. Stored food is in the form of carbohydrates which is either mannitol or laminarin.
- D. The major pigments found are chlorophyll a, c and carotenoids and xanthophyll.
- E. Vegetative cells have a cellulosic wall, usually covered on the outside by gelatinous coating of algin.

Choose the correct answer from the options given below:

- (1) A, C, D and E only
  - (2) A, B, C and E only
  - (3) A, B, C and D only
  - (4) B, C, D and E only
-

137. Match List I with List II.

List I (Types of Stamens)		List II (Example)	
A.	Monoadelphous	I.	Citrus
B.	Diadelphous	II.	Pea
C.	Polyadelphous	III.	Lily
D.	Epiphyllous	IV.	China-rose

Choose the correct answer from the options given below:

- (1) A-I, B-II, C-IV, D-III
- (2) A-II, B-I, C-IV, D-III
- (3) A-IV, B-II, C-I, D-III
- (4) A-I, B-I, C-II, D-IV

138. Spraying sugarcane crop with which of the following plant growth regulators, increases the length of stem, thus, increasing the yield?

- (1) Cytokinin
- (2) Abscisic acid
- (3) Auxin
- (4) Gibberellin

139. Identify the correct description about the given figure:

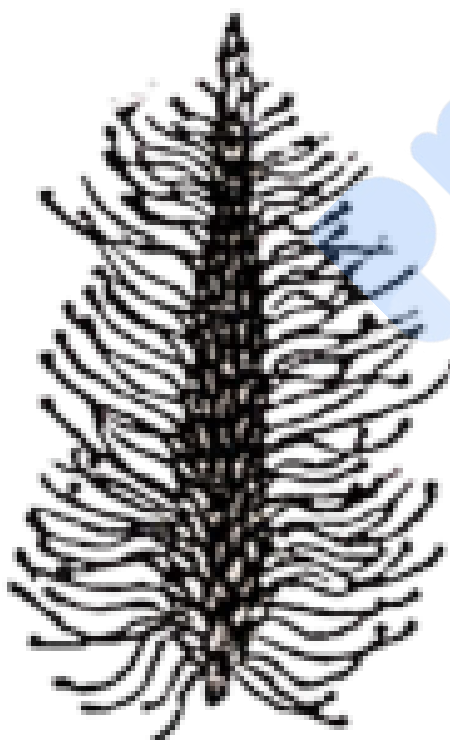

- (1) Cleistogamous flowers showing autogamy
- (2) Compact inflorescence showing complete autogamy
- (3) Wind pollinated plant inflorescence showing flowers with well exposed stamens
- (4) Water pollinated flowers showing stamens with mucilaginous covering

140. Which of the following are fused in somatic hybridization involving two varieties of plants?

- (1) Protoplasts
- (2) Pollens
- (3) Callus
- (4) Somatic embryos

141. Identify the step in tricarboxylic acid cycle, which does not involve oxidation of substrate.

- (1) Succinyl-CoA  $\rightarrow$  Succinic acid
- (2) Isocitrate  $\rightarrow$   $\alpha$ -ketoglutaric acid
- (3) Malic acid  $\rightarrow$  Oxaloacetic acid
- (4) Succinic acid  $\rightarrow$  Malic acid

142. Match List I with List II.

List I		List II	
A.	Robert May	I.	Species-Area relationship
B.	Alexander von Humboldt	II.	Long term ecosystem experiment using outdoor plots
C.	Paul Ehrlich	III.	Global species diversity at about 7 million
D.	David Tilman	IV.	Rivet popper hypothesis

Choose the correct answer from the options given below:

- (1) A-I, B-III, C-IV, D-II
- (2) A-III, B-IV, C-II, D-I
- (3) A-II, B-III, C-I, D-IV
- (4) A-III, B-I, C-IV, D-II

143. Match List I with List II.

List I		List II	
A.	Rose	I.	Twisted aestivation
B.	Pea	II.	Perigynous flower
C.	Cotton	III.	Drupe
D.	Mango	IV.	Marginal placentation

Choose the correct answer from the options given below :

- (1) A-I, B-II, C-III, D-IV
- (2) A-II, B-III, C-IV, D-I
- (3) A-III, B-IV, C-I, D-III
- (4) A-I, B-II, C-III, D-IV

144. Match List-I with List-II.

List I		List II	
A.	GLUT-4	I.	Hormone
B.	Insulin	II.	Enzyme
C.	Trypsin	III.	Intercellular ground substance
D.	Collagen	IV.	Enables glucose transport into cells

Choose the correct answer from the options given below :

- (1) A-IV, B-I, C-II, D-III
  - (2) A-III, B-IV, C-I, D-II
  - (3) A-IV, B-I, C-II, D-III
  - (4) A-I, B-II, C-III, D-IV
- 

145. The DNA present in chloroplast is:

- (1) Linear, single stranded
  - (2) Circular, single stranded
  - (3) Linear, double stranded
  - (4) Circular, double stranded
- 

146. Given below are two statements:

**Statement I:** In C<sub>3</sub> plants, some O<sub>2</sub> binds to RuBisCO, hence CO<sub>2</sub> fixation is decreased.

**Statement II:** In C<sub>4</sub> plants, mesophyll cells show very little photorespiration while bundle sheath cells do not show photorespiration.

- (1) Statement I is true but Statement II is false
  - (2) Statement I is false but Statement II is true
  - (3) Both Statement I and Statement II are true
  - (4) Both Statement I and Statement II are false
- 

147. Which of the following statement is correct regarding the process of replication in *E. coli*?

- (1) The DNA dependent DNA polymerase catalyzes polymerization in 5' → 3' as well as 3' → 5' direction
  - (2) The DNA dependent DNA polymerase catalyzes polymerization in 5' → 3' direction
  - (3) The DNA dependent DNA polymerase catalyzes polymerization in one direction that is 3' → 5'
  - (4) The DNA dependent RNA polymerase catalyzes polymerization in one direction, that is 5' → 3'
- 

148. Match List I with List II.

List I		List II	
A.	Frederick Griffith	I.	Genetic code
B.	Francois Jacob & Jacque Monod	II.	Semi-conservative mode of DNA replication
C.	Har Gobind Khorana	III.	Transformation
D.	Meselson & Stahl	IV.	Lac operon

Choose the correct answer from the options given below:

- (1) A-III, B-IV, C-I, D-II
  - (2) A-IV, B-I, C-II, D-III
  - (3) A-IV, B-I, C-II, D-III
  - (4) A-III, B-IV, C-I, D-II
- 

149. Match List I with List II.

List I		List II	
A.	Citric acid cycle	I.	Cytoplasm
B.	Glycolysis	II.	Mitochondrial matrix
C.	Electron transport system	III.	Intermembrane space of mitochondria
D.	Proton gradient	IV.	Inner mitochondrial membrane

Choose the correct answer from the options given below:

- (1) A-III, B-IV, C-I, D-II
- (2) A-IV, B-III, C-II, D-I
- (3) A-I, B-II, C-III, D-IV
- (4) A-II, B-I, C-IV, D-III

150. In an ecosystem if the Net Primary Productivity (NPP) of first trophic level is  $100x$  ( $\text{kcal m}^{-2} \text{yr}^{-1}$ ), what would be the GPP (Gross Primary Productivity) of the third trophic level of the same ecosystem?

- (1)  $10x$  ( $\text{kcal m}^{-2} \text{yr}^{-1}$ )
- (2)  $\frac{100x}{3}$  ( $\text{kcal m}^{-2} \text{yr}^{-1}$ )
- (3)  $\frac{x}{10}$  ( $\text{kcal m}^{-2} \text{yr}^{-1}$ )
- (4)  $x$  ( $\text{kcal m}^{-2} \text{yr}^{-1}$ )

151. Match List I with List II.

List I		List II	
A.	Fibrous joints	I.	Adjacent vertebrae, limited movement
B.	Cartilaginous joints	II.	Humerus and Pectoral girdle, rotational movement
C.	Hinge joints	III.	Skull, don't allow any movement
D.	Ball and socket joints	IV.	Knee, help in locomotion

Choose the correct answer from the options given below :

- (1) A-I, B-III, C-I, D-IV
- (2) A-II, B-I, C-IV, D-II
- (3) A-IV, B-II, C-III, D-I
- (4) A-I, B-III, C-II, D-IV

152. Match List I with List II.

List I		List II	
A.	Typhoid	I.	Fungus
B.	Leishmaniasis	II.	Nematode
C.	Ringworm	III.	Protozoa
D.	Filariasis	IV.	Bacteria

Choose the correct answer from the options given below:

- (1) A-III, B-I, C-IV, D-II
- (2) A-II, B-IV, C-III, D-I
- (3) A-I, B-III, C-II, D-IV
- (4) A-IV, B-III, C-I, D-II

**153. In both sexes of cockroach, a pair of jointed filamentous structures called anal cerci are present on the segment:**

- (1) 8th and 9th segment
- (2) 11th segment
- (3) 5th segment
- (4) 10th segment

**154. Which of the following is not a component of Fallopian tube?**

- (1) Infundibulum
- (2) Ampulla
- (3) Uterine fundus
- (4) Isthmus

**155. Given below are two statements:**

**Statement I: The presence or absence of hymen is not a reliable indicator of virginity.**

**Statement II: The hymen is torn during the first coitus only.**

**In the light of the above statements, choose the correct answer from the options given below :**

- (1) Statement I is true but Statement II is false
- (2) Statement I is false but Statement II is true
- (3) Both Statement I and Statement II are true
- (4) Both Statement I and Statement II are false

**156. Which of the following are Autoimmune disorders?**

- A. Myasthenia gravis
- B. Rheumatoid arthritis
- C. Gout
- D. Muscular dystrophy
- E. Systemic Lupus Erythematosus (SLE)

**Choose the most appropriate answer from the options given below**

- (1) B, C & E only
- (2) C, D & E only
- (3) A, B & D only
- (4) A, B & E only

**157. Match List I with List II.**

List I (Sub Phases of Prophase I)		List II (Specific Characters)	
A.	Diakinesis	I.	Synaptonemal complex formation
B.	Pachytene	II.	Completion of terminalisation of chiasmata
C.	Zygotene	III.	Chromosomes look like thin threads
D.	Leptotene	IV.	Appearance of recombination nodules

**Choose the correct answer from the options given below**

- (1) A-II, B-IV, C-I, D-III
- (2) A-IV, B-III, C-II, D-I

(3) A-IV, B-I, C-III, D-II

(4) A-I, B-II, C-IV, D-III

158. Given below are some stages of human evolution.

A. *Homo habilis*

B. *Homo sapiens*

C. *Homo neanderthalensis*

D. *Homo erectus*

Arrange them in correct sequence. (Past to Recent)

(1) C-B-D-A

(2) A-D-C-B

(3) D-A-C-B

(4) B-A-D-C

159. Match List I with List II:

List I		List II	
A.	Expiratory capacity	I.	Expiratory reserve volume + Tidal volume + Inspiratory reserve volume
B.	Functional residual capacity	II.	Tidal volume + Expiratory reserve volume
C.	Vital capacity	III.	Tidal volume + Inspiratory reserve volume
D.	Inspiratory capacity	IV.	Expiratory reserve volume + Residual volume

Choose the correct answer from the options given below :

(1) A-II, B-I, C-IV, D-III

(2) A-I, B-III, C-II, D-IV

(3) A-II, B-IV, C-I, D-III

(4) A-III, B-II, C-IV, D-I

160. Match List I with List II:

List I		List II	
A.	Pons	I.	Provides additional space for Neurons, regulates posture and balance.
B.	Hypothalamus	II.	Controls respiration and gastric secretions.
C.	Medulla	III.	Connects different regions of the brain.
D.	Cerebellum	IV.	Neuro secretory cells

Choose the correct answer from the options given below :

(1) A-I, B-III, C-II, D-IV

(2) A-II, B-I, C-III, D-IV

(3) A-III, B-II, C-I, D-IV

(4) A-III, B-IV, C-II, D-I

---

161. Given below are two statements:

Statement I: In the nephron, the descending limb of loop of Henle is impermeable to water and permeable to electrolytes.

Statement II: The proximal convoluted tubule is lined by simple columnar brush border epithelium and increases the surface area for reabsorption.

In the light of the above statements, choose the correct answer from the option given below :

(1) Statement I is true but Statement II is false

(2) Statement I is false but Statement II is true

(3) Both Statement I and Statement II are true

(4) Both Statement I and Statement II are false

---

162. Which of the following is not a steroid hormone?

(1) Progesterone

(2) Glucagon

(3) Cortisol

(4) Testosterone

---

163. Match List I with List II:

List I		List II	
A.	<i>Pterophyllum</i>	I.	Hag fish
B.	<i>Myxine</i>	II.	Saw fish
C.	<i>Pristis</i>	III.	Angel fish
D.	<i>Exocoetus</i>	IV.	Flying fish

Choose the correct answer from the options given below :

(1) A-IV, B-I, C-II, D-III

(2) A-III, B-II, C-I, D-IV

(3) A-II, B-I, C-III, D-IV

(4) A-III, B-I, C-II, D-IV

---

164. Which one is the correct product of DNA dependent RNA polymerase to the given template?

Template DNA: 3'TACTGCGAAATCATCATTTCAG5'

(1) 5'AUGUACCGUUUAAGGAGAAGU3'

(2) 5'ATGACCGTTAATAGGAGAAGT3'

(3) 5'AUGUACCGUUUAAGGAGAAGU3'

(4) 5'AUGUAAAGUUUAAGGUAAGU3'

---

165. Which of the following statements is incorrect?

(1) Bio-reactors are used to produce small scale bacterial cultures

(2) Bio-reactors have an agitator system, an oxygen delivery system and foam control

---

system

- (3) A bio-reactor provides optimal growth conditions for achieving the desired product  
 (4) Most commonly used bio-reactors are of stirring type

166. Three types of muscles are given as a, b, and c. Identify the correct matching pair along with their location in the human body:

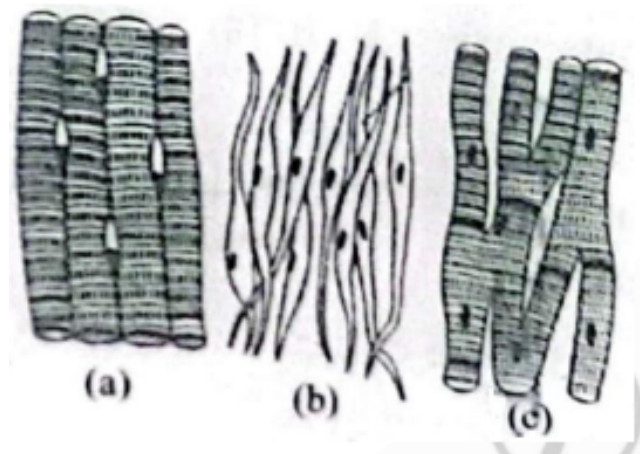

Name of Muscle/Location.

- (1) (a) Skeletal - Biceps, (b) Involuntary - Intestine, (c) Smooth - Heart  
 (2) (a) Involuntary - Nose tip, (b) Skeletal - Bone, (c) Cardiac - Heart  
 (3) (a) Smooth - Toes, (b) Skeletal - Legs, (c) Cardiac - Heart  
 (4) (a) Skeletal - Triceps, (b) Smooth - Stomach, (c) Cardiac - Heart

167. Which one of the following factors will not affect the Hardy-Weinberg equilibrium?

- (1) Gene migration  
 (2) Constant gene pool  
 (3) Genetic recombination  
 (4) Genetic drift

168. Which of the following is not a natural/traditional contraceptive method?

- (1) Lactational amenorrhea  
 (2) Vaults  
 (3) Coitus interruptus  
 (4) Periodic abstinence

169. The following diagram showing restriction sites in *E. coli* cloning vector pBR322. Find the role of 'X' and 'Y' genes:

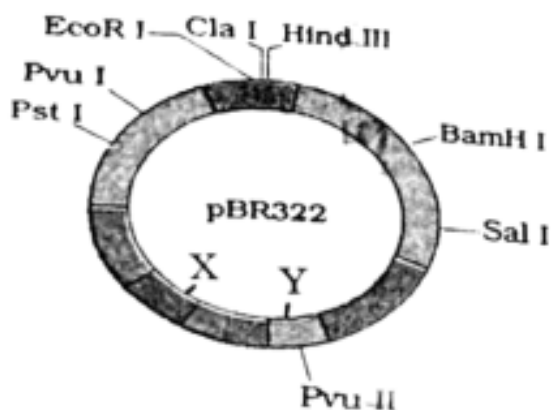

- (1) The gene 'X' is for protein involved in replication of Plasmid and 'Y' for resistance to antibiotics.
- (2) Gene 'X' is responsible for recognitions sites and 'Y' is responsible for antibiotic resistance.
- (3) The gene 'X' is responsible for resistance to antibiotics and 'Y' for protein involved in the replication of Plasmid.
- (4) The gene 'X' is responsible for controlling the copy number of the linked DNA and 'Y' for protein involved in the replication of Plasmid.

170. Match List I with List II:

List-I		List-II	
A.	Lipase	I.	Peptide bond
B.	Nuclease	II.	Ester bond
C.	Protease	III.	Glycosidic bond
D.	Amylase	IV.	Phosphodiester bond

Choose the correct answer from the options given below :

- (1) A-II, B-IV, C-I, D-III
- (2) A-IV, B-I, C-III, D-II
- (3) A-IV, B-II, C-III, D-I
- (4) A-III, B-II, C-I, D-IV

Choose the correct answer from the options given below :

171. Which of the following factors are favourable for the formation of oxyhaemoglobin in alveoli?

- (1) Low  $p\text{CO}_2$  and High  $\text{H}^+$  concentration
- (2) Low  $p\text{CO}_2$  and High temperature
- (3) High  $p\text{O}_2$  and High  $p\text{CO}_2$
- (4) High  $p\text{O}_2$  and Lesser  $\text{H}^+$  concentration

172. Match List I with List II:

List I		List II	
A.	Common cold	I.	Plasmodium
B.	Haemozoin	II.	Typhoid
C.	Widal test	III.	Rhinoviruses
D.	Allergy	IV.	Dust mites

Choose the correct answer from the options given below :

- (1) A-III, B-I, C-II, D-IV
- (2) A-IV, B-II, C-III, D-I
- (3) A-II, B-IV, C-III, D-I
- (4) A-I, B-III, C-II, D-IV

173. Given below are two statements: One is labelled as Assertion A and the other is labelled as Reason R:

**Assertion A:** Breast-feeding during initial period of infant growth is recommended by doctors for bringing a healthy baby.

**Reason R:** Colostrum contains several antibodies absolutely essential to develop resistance for the new born baby.

In the light of the above statements, choose the most appropriate answer from the options given below:

- (1) A is correct but R is not correct
- (2) A is not correct but R is correct
- (3) Both A and R are correct and R is the correct explanation of A
- (4) Both A and R are correct but R is NOT the correct explanation of A

174. Match List I with List II:

List I		List II	
A.	Non-medicated IUD	I.	Multiload 375
B.	Copper releasing IUD	II.	Progestogens
C.	Hormone releasing IUD	III.	Lippes loop
D.	Implants	IV.	LNG-20

Choose the correct answer from the options given below:

- (1) A-IV, B-I, C-II, D-III
- (2) A-III, B-I, C-IV, D-II
- (3) A-II, B-I, C-III, D-IV
- (4) A-I, B-III, C-II, D-IV

175. Following are the stages of cell division:

- A. Gap 2 phase
- B. Cytokinesis
- C. Synthesis phase
- D. Karyokinesis
- E. Gap 1 phase

Choose the correct sequence of stages from the options given below:

- (1) B-D-E-A-C
- (2) E-C-A-D-B
- (3) C-E-D-A-B
- (4) E-B-D-A-C

176. Match List I with List II:

List I		List II	
A.	Pleurobrachia	I.	Mollusca
B.	Radula	II.	Ctenophora
C.	Stomochord	III.	Osteichthyes
D.	Air bladder	IV.	Hemichordata

Choose the correct answer from the options given below:

- (1) A-II, B-IV, C-I, D-III
- (2) A-IV, B-III, C-II, D-I
- (3) A-IV, B-II, C-III, D-I
- (4) A-II, B-I, C-IV, D-III

177. The flippers of the Penguins and Dolphins are the example of:

- (1) Convergent evolution
- (2) Divergent evolution
- (3) Adaptive radiation
- (4) Natural selection

178. Match List I with List II:

List I		List II	
A.	Axoneme	I.	Centriole
B.	Cartwheel pattern	II.	Cilia and flagella
C.	Crista	III.	Chromosome
D.	Satellite	IV.	Mitochondria

Choose the correct answer from the options given below:

- (1) A-II, B-IV, C-I, D-III
- (2) A-II, B-I, C-IV, D-III
- (3) A-IV, B-III, C-II, D-I
- (4) A-IV, B-II, C-III, D-I

179. Following are the stages of pathway for conduction of an action potential through the heart:

- A. AV bundle
- B. Purkinje fibres
- C. AV node
- D. Bundle branches

### E. SA node

Choose the correct sequence of pathway from the options given below:

- (1) B-D-E-C-A
- (2) E-A-D-B-C
- (3) E-C-A-D-B
- (4) A-E-C-B-D

180. The "Ti plasmid" of *Agrobacterium tumefaciens* stands for:

- (1) Tumor inducing plasmid
- (2) Temperature independent plasmid
- (3) Tumour inhibiting plasmid
- (4) Tumor independent plasmid

181. Match List I with List II:

List I		List II	
A.	Cocaine	I.	Effective sedative in surgery
B.	Heroin	II.	Cannabis sativa
C.	Morphine	III.	Erythroxyllum
D.	Marijuana	IV.	Papaver somniferum

Choose the correct answer from the options given below:

- (1) A-I, B-I, C-III, D-IV
- (2) A-III, B-IV, C-I, D-II
- (3) A-IV, B-III, C-I, D-II
- (4) A-I, B-III, C-II, D-IV

182. Match List I with List II:

List I		List II	
A.	Down's syndrome	I.	11 <sup>th</sup> chromosome
B.	$\alpha$ -Thalassemia	II.	'X' chromosome
C.	$\beta$ -Thalassemia	III.	21 <sup>st</sup> chromosome
D.	Klinefelter's syndrome	IV.	16 <sup>th</sup> chromosome

Choose the correct answer from the options given below:

- (1) A-III, B-IV, C-I, D-II
- (2) A-IV, B-I, C-III, D-II
- (3) A-I, B-III, C-II, D-IV
- (4) A-II, B-III, C-IV, D-I

183. Match List I with List II:

List I		List II	
A.	$\alpha$ -1 antitrypsin	I.	Cotton bollworm
B.	Cry IAb	II.	ADA deficiency
C.	Cry IA <sub>c</sub>	III.	Emphysema
D.	Enzyme replacement therapy	IV.	Corn borer

Choose the correct answer from the options given below:

- (1) A-III, B-IV, C-I, D-II
  - (2) A-II, B-IV, C-I, D-III
  - (3) A-II, B-I, C-IV, D-III
  - (4) A-III, B-I, C-II, D-IV
- 

**184. Consider the following statements:**

- A. Annelids are true coelomates.
- B. Poriferans are pseudocoelomates.
- C. Aschelminthes are acoelomates.
- D. Platyhelminthes are pseudocoelomates.

**Choose the correct answer from the options given below:**

- (1) C only
  - (2) D only
  - (3) B only
  - (4) A only
- 

**185. Given below are two statements: one is labelled as Assertion A and the other is labelled as Reason R:**

**Assertion A: FSH acts upon ovarian follicles in female and Leydig cells in male.**

**Reason R: Growing ovarian follicles secrete estrogen in female while interstitial cells secrete androgen in male human being.**

**In the light of the above statements, choose the correct answer from the options given below:**

- (1) A is true but R is false.
  - (2) A is false but R is true.
  - (3) Both A and R are true and R is the correct explanation of A.
  - (4) Both A and R are true but R is NOT the correct explanation of A.
- 

## SECTION-B

**186. Given below are two statements:**

**Statement I: Mitochondria and chloroplasts both double membranes bound organelles.**

**Statement II: Inner membrane of mitochondria is relatively less permeable, as compared chloroplast.**

**In the light of the above statements, choose the most appropriate answer from the options given below:**

- (1) Statement I is correct but Statement II is incorrect.
- (2) Statement I is incorrect but Statement II is correct.
- (3) Both Statement I and Statement II are correct.

(4) Both Statement I and Statement II are incorrect.

187. Regarding catalytic cycle of an enzyme action, select the correct sequential steps:

- A. Substrate-enzyme complex formation.
- B. Free enzyme ready to bind with another substrate.
- C. Release of products.
- D. Chemical bonds of the substrate broken.
- E. Substrate binding to active site.

Choose the correct answer from the options given below:

- (1) B, A, C, D, E
- (2) E, D, C, B, A
- (3) E, A, D, C, B
- (4) A, E, B, D, C

188. Given below are two statements:

Statement I: Gause's competitive exclusion principle states that two closely related species competing for different resources cannot exist indefinitely.

Statement II: According to Gause's principle, during competition, the inferior will be eliminated. This may be true if resources are limiting.

In the light of the above statements, choose the correct answer from the options given below:

- (1) Statement I is true but Statement II is false.
- (2) Statement I is false but Statement II is true.
- (3) Both Statement I and Statement II are true.
- (4) Both Statement I and Statement II are false.

189. Match List I with List II:

List I		List II	
A.	Exophthalmic goiter	I.	Excess secretion of cortisol, moon face & hyperglycemia
B.	Acromegaly	II.	Hypo-secretion of thyroid hormone and stunted growth
C.	Cushing's syndrome	III.	Hyper secretion of thyroid hormone & protruding eye balls
D.	Cretinism	IV.	Excessive secretion of growth hormone

Choose the correct answer from the options given below :

- (1) A-III, B-IV, C-II, D-I
- (2) A-III, B-IV, C-I, D-II
- (3) A-IV, B-III, C-II, D-I
- (4) A-IV, B-II, C-I, D-III

190. Per ABO blood grouping system, the blood group of father is B+, mother is A+ and child is O+. Their respective genotype can be:

- A.  $I^B i / I^A i / ii$
- B.  $I^B I^B / I^A I^A / ii$
- C.  $I^A I^B / ii / I^B i$
- D.  $I^A i / I^B i / I^A i$

E.  $iI^B/iI^A/I^A I^B$

Choose the most appropriate answer from the options given below:

- (1) C & B only
  - (2) D & E only
  - (3) A only
  - (4) B only
- 

191. The following are the statements about non-chordates:

- A. Pharynx is perforated by gill slits.
- B. Notochord is absent.
- C. Central nervous system is dorsal.
- D. Heart is dorsal if present.
- E. Post anal tail is absent.

Choose the most appropriate answer from the options given below:

- (1) B, D & E only
  - (2) B, C & D only
  - (3) A & C only
  - (4) A, B & D only
- 

192. Match List I with List II related to digestive system of cockroach:

List I		List II	
A.	The structures used for storing of food	I.	Gizzard
B.	Ring of 6-8 blind tubules at junction of foregut and midgut	II.	Gastric Caeca
C.	Ring of 100-150 yellow coloured thin filaments at junction of midgut and hindgut	III.	Malpighian tubules
D.	The structures used for grinding the food	IV.	Crop

Choose the correct answer from the options given below:

- (1) A-I, B-II, C-III, D-IV
  - (2) A-III, B-II, C-IV, D-I
  - (3) A-IV, B-II, C-III, D-I
  - (4) A-I, B-III, C-II, D-IV
- 

193. Choose the correct statement given below regarding juxta medullary nephron:

- (1) Loop of Henle of juxta medullary nephron runs deep into medulla.
  - (2) Juxta medullary nephrons outnumber the cortical nephrons.
  - (3) Juxta medullary nephrons are located in the columns of Bertini.
  - (4) Renal corpuscle of juxta medullary nephron lies in the outer portion of the renal medulla.
- 

194. Match List I with List II:

List I		List II	
A.	P wave	I.	Heart muscles are electrically silent.
B.	QRS complex	II.	Depolarisation of ventricles.
C.	T wave	III.	Depolarisation of atria.
D.	T-P gap	IV.	Repolarisation of ventricles.

Choose the correct answer from the options given below :

- (1) A-I, B-III, C-IV, D-II
- (2) A-IV, B-II, C-I, D-III
- (3) A-I, B-II, C-IV, D-III
- (4) A-III, B-II, C-IV, D-I

195. Identify the correct option (A), (B), (C), (D) with respect to spermatogenesis:

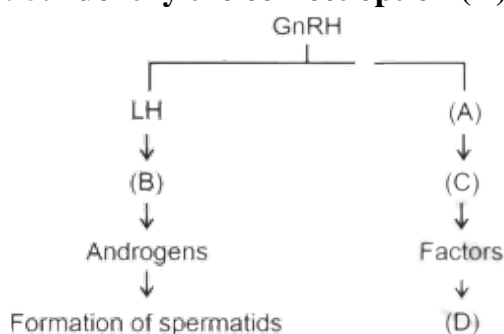

- (1) FSH, Sertoli cells, Leydig cells, spermatogenesis.
- (2) ICSH, Leydig cells, Sertoli cells, spermatogenesis.
- (3) FSH, Leydig cells, Sertoli cells, spermiogenesis.
- (4) ICSH, Interstitial cells, Leydig cells, spermiogenesis.

196. Match List I with List II:

List I		List II	
A.	Unicellular glandular epithelium	I.	Salivary glands
B.	Compound epithelium	II.	Pancreas
C.	Multicellular glandular epithelium	III.	Goblet cells of alimentary canal
D.	Endocrine glandular epithelium	IV.	Moist surface of buccal cavity

Choose the correct answer from the options given below:

- (1) A-III, B-IV, C-I, D-II
- (2) A-II, B-I, C-IV, D-III
- (3) A-II, B-I, C-III, D-IV
- (4) A-IV, B-III, C-I, D-II

197. Given below are two statements:

Statement I: The cerebral hemispheres are connected by nerve tract known as corpus callosum.

Statement II: The brain stem consists of the medulla oblongata, pons and cerebrum.

In the light of the above statements, choose the most appropriate answer from the options given below:

- (1) Statement I is correct but Statement II is incorrect.

- (2) Statement I is incorrect but Statement II is correct.  
 (3) Both Statement I and Statement II are true.  
 (4) Both Statement I and Statement II are incorrect.

**198. Match List I with List II:**

List I		List II	
A.	Mesozoic Era	I.	Lower invertebrates
B.	Proterozoic Era	II.	Fish & Amphibia
C.	Cenozoic Era	III.	Birds & Reptiles
D.	Paleozoic Era	IV.	Mammals

Choose the correct answer from the options given below :

- (1) A-I, B-II, C-IV, D-III  
 (2) A-III, B-I, C-IV, D-II  
 (3) A-II, B-I, C-III, D-IV  
 (4) A-III, B-I, C-II, D-IV

**199. Match List I with List II:**

List I		List II	
A.	RNA polymerase III	I.	snRNPs
B.	Termination of transcription	II.	Promotor
C.	Splicing of Exons	III.	Rho factor
D.	TATA box	IV.	SnRNAs, tRNA

Choose the correct answer from the options given below :

- (1) A-III, B-IV, C-I, D-II  
 (2) A-IV, B-III, C-I, D-II  
 (3) A-II, B-IV, C-I, D-III  
 (4) A-IV, B-II, C-IV, D-I

**200. Given below are two statements:**

**Statement I:** Bone marrow is the main lymphoid organ where all blood cells including lymphocytes are produced.

**Statement II:** Both bone marrow and thymus provide micro environments for the development and maturation of T-lymphocytes.

In the light of above statements, choose the most appropriate answer from the options given below :

- (1) Statement I is correct but Statement II is incorrect.  
 (2) Statement I is incorrect but Statement II is correct.  
 (3) Both Statement I and Statement II are correct.  
 (4) Both Statement I and Statement II are incorrect.