

Prepp

Your Personal Exams Guide



NDA



CDS



SSC CGL



CBSE UGC NET



IAS



SSC CHSL



CTET



MPSC



AFCAT



CSIR UDC NET



IBPS PO



UP POLICE



SSC MTS



SBI PO



BPSC



UPTET



IBPS RRB



IBPS CLERK



IES



UPSC CAPF



SSC Stenogr..



RRB NTPC



SSC GD



RBI GRADE B



RBI Assistant



DSSSB

UP Junior Aided Teacher (UPJASE) 2021 Prev. Yr. Paper (Science & Mathematics)

Total Time: 2 Hour : 30 Minute

Total Marks: 150

Instructions

1. Test will auto submit when the Time is up.
2. The Test comprises of multiple choice questions (MCQ) with one or more correct answers.
3. The clock in the top right corner will display the remaining time available for you to complete the examination.

Navigating & Answering a Question

1. The answer will be saved automatically upon clicking on an option amongst the given choices of answer.
2. To deselect your chosen answer, click on the clear response button.
3. The marking scheme will be displayed for each question on the top right corner of the test window.

Your Personal Exams Guide

General Knowledge

1. In which year Akbar ended the Jiziya Tax for the first time? (+1)
- a. 1564
 - b. 1567
 - c. 1565
 - d. 1566
-
2. Who was elected as the President of Indian National Congress in 1938? (+1)
- a. Abul Kalam Azad
 - b. Subhash Chandra Bose
 - c. J. B. Kriplani
 - d. Pattabhi Sitaramaiya
-
3. In which of the following years Surendra Nath Banerjee was removed from Civil Services? (+1)
- a. 1870
 - b. 1878
 - c. 1867
 - d. 1874
-
4. Brahmi script was deciphered by (+1)

- a. S. R. Rao
 - b. Charles Masson
 - c. Alexander Cunningham
 - d. James Princep
-

5. Arrange the following dynasties in chronological order by using the codes given below. **(+1)**

- 1. Shung dynasty
- 2. Haryank dynasty
- 3. Nand dynasty
- 4. Maurya dynasty

- a. 2, 1, 3, 4
 - b. 2, 3, 4, 1
 - c. 1, 2, 3, 4
 - d. 3, 1, 2, 4
-

6. As per census 2011, literacy rate in India is **(+1)**

- a. 74.04%
- b. 69.32%
- c. 65.55%
- d. 77.25%

7. How much allocation given for 'Mukhya Mantri Samagra Sampada Vikas Yojana' under the Budget - 2021-22 of Uttar Pradesh? **(+1)**

- a. 1000 crores
- b. 500 crores
- c. 2000 crores
- d. 5000 crores

8. Find the agent/agents of soil erosion among the following. **(+1)**

- A. Running water
 - B. Groundwater
 - C. Sea waves
- a. Only A
 - b. None of these
 - c. A and C
 - d. A, B and C

9. Biodiversity is **(+1)**

- A. Genetic variations
- B. All biological species present on earth
- C. Variations among biological communities
- D. Variations in ecosystems

- a. only B
 - b. All of these
 - c. Both B and C
 - d. A, B and C
-

10. Intensity of Noise Pollution is measured in (+1)

- a. Centimeter
 - b. Decibel
 - c. Decimeter
 - d. Deciliter
-

11. Which of the following disease is caused by virus? (+1)

- a. Typhoid
 - b. Leukemia
 - c. Filaria
 - d. Rabies
-

12. ECG is a graphical representation of the electrical activity of which organ ? (+1)

- a. Heart
- b. Liver

- c. Kidney
- d. Lungs

13. ${}^{12}_6\text{C}$ and ${}^{14}_6\text{C}$; ${}^1_1\text{H}$ and ${}^3_1\text{H}$; ${}^{35}_{17}\text{Cl}$ and ${}^{37}_{17}\text{Cl}$ are examples of _____ . (+1)

- a. Isotones
- b. Isomers
- c. Isotopes
- d. Isobars

14. Which of the following acid is mainly present in tomato ? (+1)

- a. Lactic acid
- b. Tartaric acid
- c. Acetic acid
- d. Citric acid and Malic acid

15. In which year 21st United Nation Climate Change Summit was held in Paris ? (+1)

- a. 2014
- b. 2017
- c. 2015
- d. 2016

16. Which one of the following is not correctly matched ? (+1)

- a. Ascorbic acid - Lemon
 - b. Formic acid - Milk
 - c. Maltose - Malt
 - d. Acetic acid - Curd
-

17. 'Sarthak' launched by the Ministry of Defense Government of India in August 2020 is related to which of the following? (+1)

- a. Smart bomb
 - b. Light combat aircraft
 - c. Rocket launcher
 - d. Offshore patrol ship
-

18. Which one of the following became first 100% organic Union Territory of India ? (+1)

- a. Lakshadweep
 - b. Andaman and Nicobar Islands
 - c. Puducherry
 - d. None of these
-

19. Arrange the following events in chronological order and select the correct answer from the codes given below. (+1)

1. Appointment of Simon Commission
2. Jallianwala Bagh Massacre
3. Mahatma Gandhi's Dandi March
4. Death of Ferozshah Mehta

- a. 4, 2, 1, 3
 - b. 4, 3, 2, 1
 - c. 1, 2, 4, 3
 - d. 2, 3, 4, 1
-

20. Who among the following leaders founded the revolutionary organization - 'Abhinav Bharat Society' (+1)

- a. Bhagat singh
 - b. Putin Bihari
 - c. Vinayak Damodar Savarkar
 - d. Barindra Kumar Ghose
-

21. What was the percentage of India's population to the World Population in 2011 ? (+1)

- a. 17.0
- b. 16.5
- c. 18.0
- d. 17.5

22. The Kumaon Himalaya is situated between which two rivers? (+1)

- a. Kali and Tista
 - b. Tista and Brahmaputra
 - c. Indus and Satluj
 - d. Satluj and Kali
-

23. Green Revolution is related with (+1)

- a. Production of cereal crop
 - b. Production of meat
 - c. Production of milk
 - d. Production of cotton
-

24. Which Coast of India frequently affected by cyclone ? (+1)

- a. Gujarat
 - b. West Bengal
 - c. Kerala
 - d. Odisha
-

25. Which of the following is largest rail zone of India? (+1)

- a. North-Eastern Railway Zone

- b. North-Central Railway Zone
 - c. Northern Railway Zone
 - d. Central Railway Zone
-

26. F : 216 :: L : ? (+1)

- a. 1700
 - b. 1728
 - c. 1600
 - d. 1723
-

27. In the coding language, if GANGA is describe by 711471, then the code of SARJU is (+1)

- a. 191181021
 - b. 198111021
 - c. 174117
 - d. 911810112
-

28. A man walks 8 km towards West, then walks 6 km towards North. How far he is from starting point ? (+1)

- a. 12 km
- b. 20 km
- c. 10 km

d. 14 km

29. What will be the angle between two needles (hour and minute) at 2 hour 30 minutes? (+1)

a. 120°

b. 95°

c. 105°

d. 170°

30. Find analogy. (+1)

Prayagraj : Ganga :: Ayodhya : ?

a. Gomati

b. Saraswati

c. Yamuna

d. Saryu

31. The soil which transport along with water is called (+1)

a. Alluvial

b. Muck

c. Colluvial

d. Peat

32. Sequence of species related to each other as prey and predator is termed as **(+1)**
- a. Food chain
 - b. Animal cycle
 - c. Niche
 - d. Eutrophication
-

33. Animals living at the bottom of the sea are called **(+1)**
- a. Lentic
 - b. Pelagic
 - c. Lotic
 - d. Benthic
-

34. The power of a power house is 200 Megawatt. The electrical energy produced by this power house per day will be **(+1)**
- a. 200 Megawatt hour
 - b. 4800 Joule
 - c. 4800 Megawatt hour
 - d. 4800 Megawatt
-

35. National Science Day is celebrated on **(+1)**
-

- a. 28th January
 - b. 28th April
 - c. 28th February
 - d. 28th march
-

36. The target of the mission 'Jal-Jeevan' - 'A tap in every home' started by Indian Central Government has been firstly achieved by which State? (+1)

- a. Goa
 - b. Madhya Pradesh
 - c. Sikkim
 - d. Gujarat
-

37. "Thai Poosam", a religious festival celebrated in which Indian State? (+1)

- a. Andhra Pradesh
 - b. Karnataka
 - c. Odisha
 - d. Tamil Nadu
-

38. Which State launched 'Kisan Kalyan Mission' to promote the income of farmers ? (+1)

- a. Uttar Pradesh

- b. Jharkhand
 - c. Bihar
 - d. Gujarat
-

39. Booker Award for the year 2020 has been given for which book ? (+1)

- a. Shuggie Bain
 - b. Voices of Dissent
 - c. The Republic Ethic
 - d. My Years with Rajiv : Triumph and Tragedy
-

40. Recently on which river the Shahtoot dam will be built with the consent of India and Afghanistan ? (+1)

- a. Arghandab river
 - b. Peck river
 - c. Maidan river
 - d. Kunar river
-

41. When was Goods and Service Tax (GST) implemented in India ? (+1)

- a. 1 January 2017
- b. 1 July 2017
- c. 1 April 2017

d. 1 July 2016

42. Puducherry comes under the jurisdiction of which High Court? (+1)

- a. Kerala
 - b. Calcutta
 - c. Madras
 - d. Karnataka
-

43. Which of the following was NOT the main feature of the Government of India Act, 1919 ? (+1)

- a. Dyarchy in the centre
 - b. Dyarchy at the provinces
 - c. Relaxation of Central control over the provinces
 - d. The Indian Legislature was made more representative
-

44. Who created the Brihadeshwar Temple of Tanjore ? (+1)

- a. Raja Raja Pratham
 - b. Aditya Pratham
 - c. Rajendra Pratham
 - d. Rajadhiraj Pratham
-

45. "Atal Innovation Mission" is related to which factor? (+1)
- a. Rural Development
 - b. Space Technology
 - c. Entrepreneurship Development
 - d. Information Technology
-

46. Which Indian State has the largest area under forest ? (+1)
- a. Arunachal Pradesh
 - b. Maharashtra
 - c. Chhattisgarh
 - d. Madhya Pradesh
-

47. Which of the following river does not form the delta ? (+1)
- a. Krishna
 - b. Narmada
 - c. Kaveri
 - d. Mahanadi
-

48. When Cabinet Mission came in India ? (+1)
- a. February 1946
-

- b. March 1945
 - c. January 1946
 - d. March 1946
-

49. The Vice-President in India is the Ex-officio Chairman of the (+1)

- a. Lok sabha
 - b. NITI Aayog
 - c. Finance Commission
 - d. Rajya Sabha
-

50. How many subjects are there in 11th Schedule of the Indian Constitution ? (+1)

- a. 27
- b. 20
- c. 25
- d. 29

prepp
Your Personal Exams Guide

Subject Concerned

51. Four chambered heart is found in (+1)
- a. Bird and mammal
 - b. Mammal from fishes
 - c. Reptile and bird
 - d. Amphibian and reptile
-

52. Which of the following order of the class mammalia is completely aquatic ? (+1)
- a. Carnivora
 - b. Ungulata
 - c. Cetacea
 - d. Rodentia
-

53. Nails, claws, hoofs and horns are developed from (+1)
- a. Epidermis
 - b. Cartilage
 - c. Dermis
 - d. Bone
-

54. Which of the following Vitamins is mainly responsible for blood coagulation in human being ? (+1)

- a. Vitamin E
 - b. Vitamin A
 - c. Vitamin K
 - d. Vitamin C
-

55. The animals with digging or burrowing habits shows the following type of adaptations (+1)

- a. Scansorial adaptation
 - b. Volant adaptation
 - c. Cursorial adaptation
 - d. Fossorial adaptation
-

56. Working principle of ELISA is (+1)

- a. Phagocytic process
 - b. Antigen-antibody interaction
 - c. Amplification process
 - d. Magnification process
-

57. Code of Bt toxin gene is (+1)

- a. cry
- b. alu

- c. lac
 - d. trp
-

58. In which of the following process oxygen is not required ? (+1)

- a. Photosynthesis
 - b. Aerobic respiration
 - c. Glycolysis
 - d. Electron transport system
-

59. Mycorrhiza is example of (+1)

- a. Fungistasis
 - b. Mutualism
 - c. Amensalism
 - d. Antibiosis
-

60. Which one of the following is responsible for denitrification ? (+1)

- a. Rhizobium and Azotobacter
 - b. hizobium and Nostoc
 - c. Pseudomonas and Thiobacillus
 - d. Anabaena and Nostoc
-

61. "Belladonna" medicine is obtained from which part of Atropa Belladonna ? (+1)
- a. from stem
 - b. from all the parts of plants
 - c. form root
 - d. from leaves and root
-

62. Jute is obtained by (+1)
- a. Solanum
 - b. Corchrus Capsularis
 - c. Pinus
 - d. Datura
-

63. Cotton is obtained from (+1)
- a. Gossypium
 - b. Oryza sativa
 - c. Rauwolfia
 - d. Glycine max
-

64. In compositae family the flower is (+1)
- a. Hypogynous

- b. None of these
 - c. Epigynous
 - d. Perigynous
-

65. Cocaine is obtained from (+1)

- a. Cannabis plant
 - b. Poppy plant
 - c. Atropa plant
 - d. Erythroxyllum plant
-

66. Amongst the following compounds, the compound having zero dipole moment is (+1)

- a. H_2O
 - b. ClO_2
 - c. BF_3
 - d. NF_3
-

67. Considering their atomic numbers and their Position in the periodic table, the correct order of increasing metallic character is (+1)

- a. $Si < Be < Mg < P < Na$
- b. $P < Si < Be < Mg < Na$

c. $\text{Na} < \text{Mg} < \text{Be} < \text{Si} < \text{P}$

d. $\text{Na} < \text{Si} < \text{Be} < \text{Mg} < \text{P}$

68. The chief constituent of photochemical smog is (+1)

a. NO_2 gas

b. None of these

c. PAN

d. Both 1 and 3

69. Methaemoglobinaemia disease is caused by (+1)

a. High concentration of nitrates in drinking water

b. High concentration of fluorides in drinking water

c. High concentration of nitrites in drinking water

d. High concentration of CH_4 (methane) in drinking water

70. Which of the following reactions will need maximum amount of energy? (+1)

a. $\text{Na} \rightarrow \text{Na}^+ + 1e^-$

b. $\text{C}^{2+} \rightarrow \text{C}^{3+} + 1e^-$

c. $\text{Ca}^+ \rightarrow \text{Ca}^{2+} + 1e^-$

d. $\text{K}^+ \rightarrow \text{K}^{2+} + 1e^-$

71. Which one of the following mirrors is being used in headlights of vehicles ? (+1)

- a. convex mirror
- b. none of these
- c. concave mirror
- d. plane mirror

72. The resistivity of a material is found to decrease with an increase in temperature. The material is (+1)

- a. Constantun
- b. Silver
- c. Silicon
- d. Nichrome

73. Which one of the following graph represents acceleration (a) vs Time (t) of an object moving under free fall ? (+1)

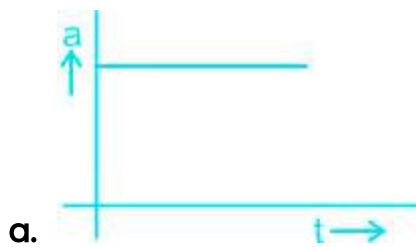

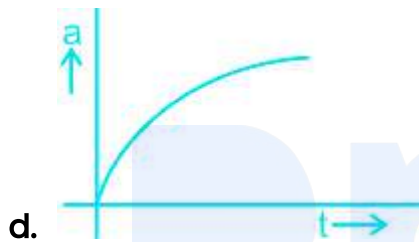
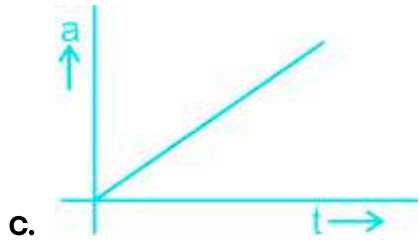
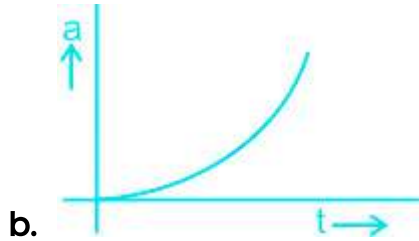

74. 1 KB (Kilobyte) is equal to

(+1)

- a. 1024 bytes
- b. 1010 bytes
- c. 1000 bytes
- d. 1020 bytes

75. Which of the following has the highest frequency ?

(+1)

- a. visible light
- b. Infra red rays
- c. Ultra violet light

d. X-rays

76. A car covers the first half of a certain distance with a speed v_1 and the second half with a speed v_2 . The average speed (v) of v_1 and v_2 during the whole journey will be **(+1)**

- a. Arithmetic mean
 - b. Harmonic mean
 - c. Half of harmonic mean
 - d. Geometric mean
-

77. At which temperature Celsius and Fahrenheit measurement is equal ? **(+1)**

- a. 0°
 - b. 100°
 - c. 40°
 - d. -40°
-

78. Which of the following is used in refrigeration? **(+1)**

- a. Sulfur dioxide
- b. Phosphine
- c. Chlorine
- d. Freon

79. Ampere-hour is an unit of (+1)
- a. Quantity of electricity
 - b. Energy
 - c. Power
 - d. Strength of electric current
-

80. The field around direct current carrying conductor is/are (where E and B are respectively represent electric field and magnetic field) (+1)
- a. Only E
 - b. Neither E nor B
 - c. Only B
 - d. both E and B
-

81. According to animal classification, which of the following group of animals is correct ? (+1)
- a. Nereis, Earthworm, Hirudinaria
 - b. Hirudinaria, Unio, Antedon
 - c. Euplectella, Spongilla, Sycon
 - d. Octopus, Starfish, Jellyfish
-

82. Amoeba is a (+1)
-

- a. unicellular animal
 - b. bacterium
 - c. unicellular plant
 - d. unicellular protist
-

83. Presence of 'Canal System' is the» characteristic feature of phylum (+1)

- a. Porifera
 - b. Echinodermata
 - c. Coelenterata
 - d. Platyhelminthes
-

84. Long bones with air cavities and lungs with air sacs are the features of class (+1)

- a. Ambhibia
 - b. Mammalia
 - c. Reptilia
 - d. Aves
-

85. Beneficial insect is (+1)

- a. Gandhi bug
- b. Culex

- c. Aphid
 - d. Apis
-

86. The rearing of silk worm is known as (+1)

- a. Horticulure
 - b. Sericulture
 - c. Aquaculture
 - d. Apiculture
-

87. Respiratory center of the body is present in the (+1)

- a. Medulla of the brain
 - b. Spinal cord
 - c. Cerebellum of the brain
 - d. Cerebral hemisphere of the brain
-

88. Loop of Henle is concerned with (+1)

- a. Reproduction
 - b. Digestion
 - c. Excretion
 - d. Respiration
-

89. Which of the following is called 'Blood bank' of human body ? (+1)

- a. Heart
 - b. Kidney
 - c. Spleen
 - d. Bone marrow
-

90. Polyp and Medusa are the alternative body forms present in the animals of kingdom (+1)

- a. Porifera
 - b. Arthropoda
 - c. Coelenterata
 - d. Annelida
-

91. The electronegativity of N, O, P and S increases in the order (+1)

- a. $N < O < P < S$
 - b. $P < N < O < S$
 - c. $S < P < N < O$
 - d. $P < S < N < O$
-

92. Point out the incorrect Statement. (+1)

- a. The gases responsible for acid rain are mainly SO_2 and NO_2 .
- b. Tetra Ethyl Lead (TEL) is added to gasoline so that the gases coming out of vehicles may not Cause air-pollution.
- c. Ozone layer in atmosphere protects us from harmful UV radiations.
- d. The incessant use of insecticides has caused soil pollution.

93. The hybridization of Xe in XeF_6 is

(+1)

- a. dsp^2
- b. sp^3d^3
- c. sp^3d
- d. sp^2

94. What is the correct order of increasing electronegativity for the following elements ?

(+1)

Li, Mg, Be, C

- a. $\text{Li} < \text{Mg} < \text{Be} < \text{C}$
- b. $\text{Be} < \text{Li} < \text{Mg} < \text{C}$
- c. $\text{Mg} < \text{Be} < \text{Li} < \text{C}$
- d. $\text{C} < \text{Mg} < \text{Li} < \text{Be}$

95. The product 'X' in the following reaction

(+1)

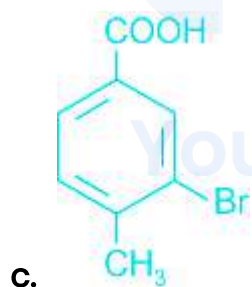
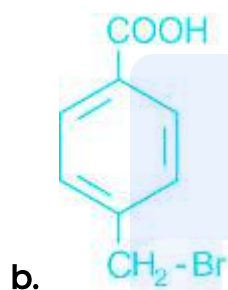
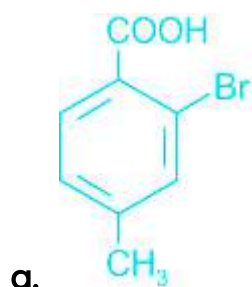
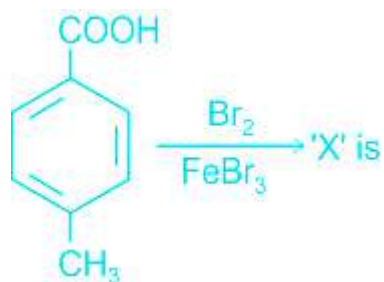

prepp

Your Personal Exams Guide

96. Which property of the virus suggest that it is abiotic ? (+1)
- a. Because it has genetic material
 - b. Because it can cause disease
 - c. Because it can reproduce
 - d. Because crystalization of virus is possible
-

97. Nostoc presence in farm land can contribute in (+1)
- a. Phosphrous cycle
 - b. Water cycle
 - c. Carbondioxide cycle
 - d. Nitrogen cycle
-

98. Which one of the following is neither a Prokaryote nor an Eukaryote ? (+1)
- a. Nostoc
 - b. T. M. V
 - c. Saccharomyces
 - d. E. Coli
-

99. In which condition both the arms of chromosome are same ? (+1)
- a. Metacentric
-

- b. Submetacentric
 - c. Acrocentric
 - d. Telocentric
-

100. Which is Suicide Bag ?

(+1)

- a. Centrosome
 - b. Lysosome
 - c. Mesosome
 - d. Ribosome
-

101. Which of the following is **not** the ore of Iron ?

(+1)

- a. Magnetite
 - b. Petalite
 - c. Limonite
 - d. Hematite
-

102. Which one of the following alloys is **not** properly matched with regard to its composition?

(+1)

Alloy	Composition
(1) Brass	Copper and zinc
(2) solder	Lead and Zinc
(3) Gunmetal	Copper, Tin, and Zinc
(4) Nichrome	Nickel, Iron, and Chromium

- a. (1)
- b. (2)
- c. (3)
- d. (4)

Prepp

Your Personal Exams Guide

103. Which of the following compound gives the most stable carbonium ion during dehydration reaction ? (+1)

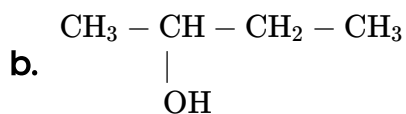
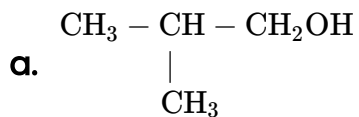

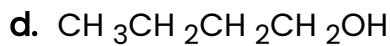
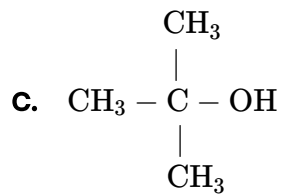

104. The acid found in tamarind is

(+1)

- a. Citric Acid
- b. Acetic Acid
- c. Ascorbic Acid
- d. Tartaric Acid

105. The order of reactivities of the following alkylhalides for $\text{S}_{\text{N}}2$ reaction is

(+1)

- a. $\text{RF} > \text{RCI} > \text{RBr} > \text{RI}$
- b. $\text{RI} > \text{RBr} > \text{RCI} > \text{RF}$
- c. $\text{RF} > \text{RBr} > \text{RCI} > \text{RI}$
- d. $\text{RCI} > \text{RBr} > \text{RF} > \text{RI}$

106. There is a hole in a copper disc, if the disc is heated, the size of the hole

(+1)

- a. Increases
- b. First increase, then decreases
- c. Decreases

d. Remains the same

107. One nanometre is equivalent to

(+1)

a. 10^{+9} mm

b. 10^{-7} cm

c. 10^{-9} cm

d. 10^{-7} mm

108. Which device converts thermal energy into electrical energy ?

(+1)

a. Hydrometer

b. Photocell

c. Thermocouple

d. Voltmeter

109. Which of the following, is non-conservative force ?

(+1)

a. Electrostatic force

b. Inter atomic force

c. Gravitational force

d. Viscous force

110. Roaring of lion has (+1)
- a. low intensity and high pitch
 - b. both low intensity-and low pitch
 - c. high intensity and low pitch
 - d. both high intensity and high pitch

111. The ratio of areas of the incircle and circumcircle of a square will be (+1)
- a. 1 : 2
 - b. 1 : 4
 - c. 1 : $\sqrt{2}$
 - d. 1 : $\sqrt{3}$

112. Consider the following table : (+1)

Marks	1-10	11-20	21-30	31-40	41-50	51-60
No. of Students	2	4	6	3	3	2

The percentage of students obtaining more than 10 and less than or equal to 40 marks is

- a. 15
- b. 74
- c. 65

d. 69

113. $\sin^{-1} \frac{5}{13} + \cos^{-1} \frac{3}{5}$ is equal to which of the following? (+1)

a. $\sin^{-1} \frac{63}{16}$

b. $\tan^{-1} \frac{63}{16}$

c. $\cos^{-1} \frac{63}{16}$

d. $\cot^{-1} \frac{63}{16}$

114. To construct a quadrilateral at least how many independent informations are required? (+1)

a. 3

b. not definite

c. 4

d. 5

115. The largest number amongst the numbers (+1)

$\sqrt{0.9}, 0.9, (0.9)^2, (0.9)^3$, is

a. 0.9

b. $\sqrt{0.9}$

c. $(0.9)^3$

d. $(0.9)^2$

116. For how many real values of n the equation $a^{2n^2+2} = 1$ has a solution? (+1)

- a. 1
- b. zero
- c. 2
- d. 4

117. If the difference of radius of two concentric circles is 2 and the distance between their centres when they touches each other externally is 8, then the radius of the bigger circle is (+1)

- a. 6
- b. 4
- c. 7
- d. 5

118. If $x^{3^n} + y^{3^n}$ is divisible by $x + y$, then (+1)

- a. $n \geq 0$, integer
- b. n is only positive even integer
- c. n is only odd integer
- d. n is only positive odd integer

119. Number of real solutions of the equation $x - \frac{1}{x^2-9} = 3 - \frac{1}{x^2-9}$ will be (+1)

- a. 0
- b. 3
- c. 1
- d. 2

120. If $x - y$ and $y - 2x$ are two factors of the expression $x^3 - 3x^2y + \lambda xy^2 + \mu y^3$, then (+1)

- a. $\lambda = \frac{11}{4}, \mu = \frac{3}{4}$
- b. $\lambda = -\frac{11}{4}, \mu = -\frac{3}{4}$
- c. $\lambda = -\frac{11}{4}, \mu = \frac{3}{4}$
- d. $\lambda = \frac{11}{4}, \mu = -\frac{3}{4}$

121. What is the area of shadowed part in the figure, if radius circle is 42 cm and $\angle AOB = 120^\circ$ and O is the centre of circle? ($\pi = 22/7$) (+1)

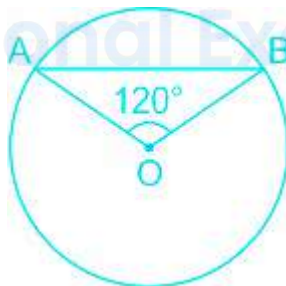

- a. $21(88 - 21\sqrt{3}) \text{ cm}^2$
- b. None of these
- c. $\frac{1}{2}(73 - \sqrt{3}) \text{ cm}^2$
- d. 42 cm^2

122. What will be the values of p and q , when $px^3 + x^2 - 2x - q$ is exactly divisible by $(x - 1)$ and $(x + 1)$? (+1)
- a. $p = 2, q = 1$
 - b. $p = -1, q = 1$
 - c. $p = 1, q = 2$
 - d. $p = 3, q = 4$
-

123. The employer decreases the number of his employees in the ratio $10 : 9$ and increases their wages in the ratio $11 : 12$, then what is the ratio of his two expenditure? (+1)
- a. $55 : 54$
 - b. $50 : 45$
 - c. $61 : 57$
 - d. $77 : 84$
-

124. If $(a + b) : (b + c) : (c + a) = 6 : 7 : 8$ and $a + b + c = 14$, then what will be the value of $a : b : c$? (+1)
- a. $3 : 7 : 4$
 - b. $6 : 7 : 8$
 - c. $7 : 5 : 9$
 - d. $12 : 14 : 16$
-

125. In the given figure O is the centre of the circle and $\angle AOB = 60^\circ$, then value of $\angle AEB$ will be (+1)

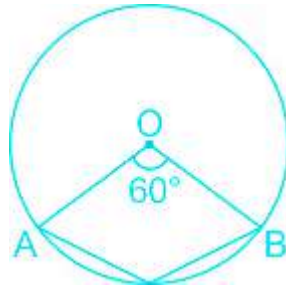

- a. 105°
 b. 105.5°
 c. 75°
 d. 150°
-
126. The sum of real roots of the equation $x^2 + |x| - 6 = 0$ is (+1)
- a. 4
 b. 5
 c. 0
 d. -1
-
127. Maximum value of the expression $2 \sin x + 4 \cos x + 3$ is (+1)
- a. $2\sqrt{5}$
 b. $\sqrt{5} + 3$
 c. $2\sqrt{5} + 3$

d. $2\sqrt{5} - 3$

128. The chord of a circle is equal to its radius. The angle subtended by this chord at any point of the minor arc of the circle is **(+1)**

a. 60°

b. 120°

c. 150°

d. 75°

129. A cone and a hemisphere have equal bases and equal volumes. The ratio of the height of cone and radius of the sphere is **(+1)**

a. 2 : 1

b. $\sqrt{3} : 1$

c. 1 : 2

d. 4 : 1

130. L.C.M. of $\frac{1}{3}$, $\frac{5}{6}$, $\frac{2}{9}$, $\frac{4}{27}$ is **(+1)**

a. $\frac{1}{27}$

b. $\frac{10}{27}$

c. $\frac{20}{3}$

d. $\frac{27}{4}$

131. If the negative roots of the quadratic equation $x^2 - px + 54 = 0$ are in the ratio 2 : 3, then the value of p is **(+1)**
- a. 15
 - b. -21
 - c. -15
 - d. -6

132. If the arithmetic mean and geometric mean of any two numbers a and b are equal, then **(+1)**
- a. $\sqrt{a+b} = ab$
 - b. $a = b$
 - c. $a + b = \sqrt{ab}$
 - d. $a + b = ab$

133. If the coordinate of three points O, A and B are respectively (0, 0), (0, 3) and (5, 0) then the circumcentre and radius of the triangle OAB are **(+1)**
- a. $(\frac{5}{4}, \frac{3}{4}), \sqrt{34}$
 - b. $(\frac{5}{2}, \frac{3}{2}), \frac{\sqrt{34}}{2}$
 - c. $(5, 3), \frac{\sqrt{34}}{4}$
 - d. $(5\sqrt{2}, 3\sqrt{2}), \frac{\sqrt{34}}{2}$

134. In a simultaneous throw of two coins, the probability of not getting a 'head' is (+1)

- a. $\frac{3}{4}$
- b. $\frac{1}{2}$
- c. $\frac{1}{4}$
- d. $\frac{1}{3}$

135. If $0 < n < 1$, then which one of the following is not true? (+1)

- a. $n^{10} > 1$
- b. $n^{100} > 1$
- c. $n^{10} < n^{100}$
- d. $\frac{1}{n^{10}} < \frac{1}{n^{100}}$

136. If $2^x = 3^y = 6^z$, then the value of $-\left(\frac{1}{x} + \frac{1}{y}\right) + \frac{1}{z} =$ (+1)

- a. 0
- b. 1
- c. $\frac{1}{3}$
- d. $\frac{1}{6}$

137. If product of two numbers be 32. If the average of these numbers is 6, then sum of the cube of these numbers will be (+1)

- a. 864
- b. 576
- c. 624
- d. 430

138. In the given figure a circle is circumscribed in quadrilateral ABCD, then $AB + CD$ (+1) will be equal to

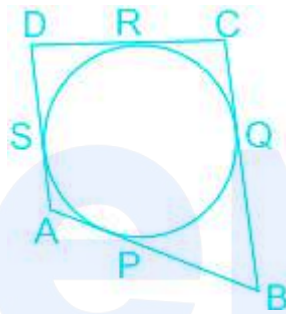

- a. $AD + BC$
- b. $2(AD + BC)$
- c. $2AD + BC$
- d. $AD + 2BC$

139. The maximum value of $\sin \theta - \cos \theta$ is (+1)

- a. 2
- b. $\frac{\sqrt{3}+1}{2}$
- c. $\sqrt{2}$
- d. 1

140. 21 workers can construct any wall in 25 days. If 14 more workers are deployed, then in how many days they will complete the whole work ? **(+1)**
- a. 21 days
 - b. 12 days
 - c. 18 days
 - d. 15 days

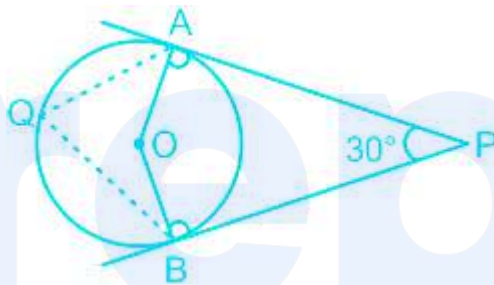

141. **(+1)**
- If in the adjacent figure PA, PB are tangents of the circle and $\angle APB = 30^\circ$, then the value of $\angle AQB$ will be
- a. 30°
 - b. 75°
 - c. 60°
 - d. 150°

142. In a single throwing of a dice, the probability of getting more than 4 is $\frac{1}{3}$ then probability of getting 4 or less than 4 will be **(+1)**
- a. $\frac{1}{3}$

b. $\frac{5}{6}$

c. $\frac{2}{3}$

d. $\frac{1}{6}$

143. The area of largest triangle that can be inscribed in a semi-circle of radius 3 cm is **(+1)**

a. 9 cm^2

b. 3 cm^2

c. 18 cm^2

d. 27 cm^2

144. If $1 < x < 2$, then what is the value of $\sqrt{x + 2\sqrt{x-1}} + \sqrt{x - 2\sqrt{x-1}}$? **(+1)**

a. 2

b. $\sqrt{x-1}$

c. $2\sqrt{x-1}$

d. $2 + 2\sqrt{x-1}$

145. The number $23.\overline{43}$ in the form $\frac{p}{q}$ (p, q are integers, $q \neq 0$) is **(+1)**

a. $\frac{2343}{100}$

b. $\frac{2320}{100}$

c. $\frac{2343}{999}$

d. $\frac{2320}{99}$

146. A person prints the price of his article to 30% more than its cost price and gives 30% discount to its printed price. His profit/loss percentage is (+1)

- a. Loss 6%
 - b. No any profit/loss
 - c. Profit 9%
 - d. Loss 9%
-

147. The algebraic expression $(x - a)(x - b)(x - c)\dots(x - y)(x - z)$ will have the degree (+1)

- a. 26
 - b. 0(zero)
 - c. undefined
 - d. 1
-

148. If α, β be the roots of the equation $x^2 - px + r = 0$ and $\frac{\alpha}{2}, 2\beta$ be the roots of the equation $x^2 - qx + r = 0$, then the value of r will be (+1)

- a. $\frac{2}{9}(p - q)(2q - p^2)$
 - b. $\frac{2}{9}(2p - q)(2q - p)$
 - c. $\frac{2}{9}(q - p)(2p - q)$
 - d. $\frac{2}{9}(q - 2p)(2q - p)$
-

149. For what values of A, $\sqrt{3} \cos \theta + \sin \theta = A$ is true ?

(+1)

- a. -3
- b. $\frac{-5}{2}$
- c. 3
- d. 0

150.

(+1)

Marks obtained	Number of students
Less than 10	3
Less than 20	7
Less than 30	13
Less than 40	16
Less than 50	21
Less than 60	27

On the basis of above table if the frequency of class interval 20 - 30 is p and of 40 - 50 is q, then the difference of p and q is

- a. 1
- b. 11
- c. 6
- d. 5

prepp

Your Personal Exams Guide

Answers

1. Answer: a

Explanation:

The correct answer is 1564.

★ Key Points

- Jizyah Tax was a per capita yearly tax historically implied on non-Muslim subjects, called the "dhimma" exempting women, children, elders, handicapped, the ill, the insane, monks, hermits etc.
- Jizya was levied on Hindus on the ground that it was not mentioned in Sharia.
- Sultan Firoz Shah Tughlaq established Sharia across his realm. He imposed Jizya upon the Brahmins and made it a separate tax.
- It was **abolished by "the third Mughal emperor Akbar", in 1564.**

★ Additional Information

- Akbar (1556 to 1605)
 - Akbar was the third Mughal emperor (1556 to 1605) and son of Humayun.
 - Akbar succeeds in the throne at just 13 years old due to the death of Humayun.
 - The kingdom Akbar inherited was little more than a collection of frail fiefs, under the regency of Bairam Khan.
 - Akbar introduced the Mansabdari system.
 - The Navratnas of Akbar were as follows: Raja Birbal, Tansen, Abul Fazal, Faizi, Raja Man Singh, Raja Todar Mal, Mullah Do Piazza, Fakir Aziao-Din, Abdul Rahim Khan-I-Khana.
 - Abul Fazl started the writing of Akbarnama in 1589.
 - It is the most detailed history of the reign of Akbar.

2. Answer: b

Explanation:

The correct answer is Subhash Chandra Bose.

★ Key Points

- Subhash Chandra Bose:
 - Subhas Chandra Bose was one of the most eminent freedom fighters of India .
 - Born in Cuttack, in the province of Bengal to an affluent family.
 - He was educated in Calcutta acquiring a degree in philosophy .
 - Subhash Chandra Bose was elected as the president of the Indian National Congress for the year 1938 .
 - Subhas Chandra Bose was Selected for the Indian Civil Services (ICS) but refused to take up service since he did not want to serve the British government.
 - Bose joined the Indian National Congress (Formed on December 28, 1885) in 1921 .
 - He also started a newspaper called 'Swaraj' .
 - He was the President of the All India Youth Congress and also the Secretary of the Bengal State Congress .

★ Additional Information

- Abul Kalam Azad:
 - Maulana Azad was born in Mecca, Saudi Arabia to a Muslim scholar from Bengal with Afghan ancestry, Maulana Muhammad Khairuddin, and his Arab wife.
 - The family had moved to Saudi Arabia after the Revolt of 1857 .
 - In 1890 they returned to Calcutta .
 - Azad mastered several languages like Urdu, Persian, Hindi, English, Bengali, and Arabic .
 - He showed erudition at a young age and was contributing articles to magazines and teaching while in his teens itself.
 - He was publishing a popular monthly magazine Lissan-us-Sidq when he was just 12 .

3. Answer: d

Explanation:

The correct answer is 1874 AD.

- Surendra Nath Banerjee was among the earliest political leaders during British rule.

★ Key Points

- He founded the Indian National Association, a Nationalist organization through which he led two sessions of the Indian National Congress in 1883 and 1885 .
- Later on, he became the senior member of the Indian National Congress and was among the founding members of it.
- He was the second Indian to qualify Indian civil service examination in 1869 but was removed from it claiming that he has misrepresented his age.
- He again cleared the examination in 1871 and got posted as an Assistant Magistrate in Sylhet, but he was soon dismissed due to a serious judicial error.

4. Answer: d

Explanation:

The correct answer is James Prinsep.

★ Key Points

- Brahmi Script
 - Brahmi is the mother script of most of the present Indian scripts including Devanagari , Bengali , Tamil , and Malayalam , etc. Hence, Statement 3 is correct.
 - It developed into two broad types in Northern and Southern India.
 - More angular in Northern India

- More circular .in Southern India
 - It was deciphered in 1837 by James Prinsep .
 - Example: Rock-cut edicts of Asoka.
-

5. Answer: b

Explanation:

The correct answer is 2,3,4,1.

★ Key Points

- The following dynasties arrange in chronological
 - Haryank dynasty
 - Nand dynasty
 - Maurya dynasty
 - Shung dynasty

★ Additional Information

Your Personal Exams Guide

Haryank dynasty	The Haryanka dynasty was the third ruling dynasty of Magadha, an empire of ancient India. Which succeeded the Pradyota dynasty and Barhadratha dynasty.
Nand dynasty	The Nanda dynasty ruled in the northern part of the Indian subcontinent during the 4th century BCE, and possibly during the 5th century BCE.
Maurya dynasty	The Maurya Empire was founded in 322 BCE by Chandragupta Maurya, who had overthrown the Nanda Dynasty and rapidly expanded his power westward across central
Shung dynasty	The Shunga Empire was an ancient Indian dynasty from Magadha that controlled areas of the central and eastern Indian subcontinent from around 184 to 75 BCE.

6. Answer: a

Explanation:

The correct answer is option 74.04%.

★ Key Points

- According to the 2011 census, the literacy rate in India is **74%**.
- To be more precise the literacy rate was 74.04%.
- The literacy rate of the male population and the female population was 82.10% and 65.46% respectively.
- The literacy rate in the 2001 census was 64.8% .
- The 2011 Census was the 15th Indian Census with the motto 'Our Census, Our future' .
- The Census was conducted in two phases, the House Listing being the first and Population Enumeration being the second.

- It was the first time when the biometric information was collected.
-

7. Answer: a

Explanation:

The correct answer is Rs. 1000 Crore.

★ Key Points

- Mukhya Mantri Samagra Sampada Vikas Yojna is a city development project which is announced by the Uttar Pradesh government during the Budget.
- Under the component of Pradhan Mantri Awas Yojana (Shahri) a target has been fixed to construct 4 lakh houses from the year 2018 to 2021, which will be in addition to the houses to be constructed by SUDA.
- A provision of Rs. 140 crore for the overall development of Suryakund at Ayodhya and the city development.
- A provision of Rs. 2,000 crore under the Smart City Scheme in 10 selected cities of the state - Lucknow, Kanpur, Prayagraj, Varanasi, Agra, Saharanpur, Bareilly, Jhansi, Moradabad, and Aligarh.
- A provision of Rs. 15 crores for the construction of a park/exhibition site/auditorium in memory of the martyrs is made.

★ Additional Information

- Chief Minister of Uttar Pradesh - Yogi Aditya Nath
 - Home Minister of Uttar Pradesh - Yogi Aditya Nath
 - State Flower of Uttar Pradesh - Palash
 - State Bird of Uttar Pradesh - Sarus Crane
 - State Animal of Uttar Pradesh - Barasingha
-

8. Answer: c

Explanation:

The correct answer is **A and C.**

★ Key Points

- Soil Erosion
 - Destruction of the soil cover is known as soil erosion. generally, the rate of removal of fine particles, i.e., Soil erosion, is equal to the rate of soil formation.
 - But if the soil balance is disturbed by natural and human factors; wind and water are powerful agents of soil erosion.
 - Sheet erosion : On flat lands, due to heavy rainfall removes finer and more fertile topsoil.
 - Gully erosion : On steep slopes. A region with a large number of deep gullies/ ravines is called a badland topography in the Chambal basin, Tamil Nadu, and West Bengal.
 - Eroded materials are carried by rivers increasing their value and can cause floods by reducing the carrying capacity of rivers.
- Causes of soil erosion :
 - Wind: When strong winds blow, the topsoil along with the organic matter is carried away by the wind. This happens more often when the land is not covered with grass or plants.
 - Water: When it rains in the hilly areas, the soil gets washed away towards the plains. The running water deposits the mineral-rich soil in the riverbed.
 - Overgrazing: When cattle are allowed to graze on the same field repeatedly, all the available grass, including the roots are eaten by them. This makes the topsoil vulnerable to wind and flowing water, leading to soil erosion.
 - Deforestation: Humans have taken land from the forest to cultivate in order to feed the ever-increasing population and to build houses, industries, etc. Cutting down trees on a large scale for these purposes is known as deforestation.

★ Important Points

- Soil Conservation:

- It is a methodology to maintain soil fertility, prevent soil erosion and exhaustion, and improve the degraded condition of the soil.
- **Method of Soil conservation –**
 - Contour bunding
 - Contour terracing
 - Regulated forestry
 - Agro-forestry in arid areas
 - Controlled grazing
 - Cover cropping
 - Mixed farming
 - Crop rotation
 - Construction of check dams to prevent gullies.
 - Lands with a 15–25 % gradient should not be cultivated without terracing .
 - Finger gullies are eliminated by terracing.
 - The extension of gullies is checked by Gully plugging .
- Central Arid Zone Research Institute (CAZRI) is involved in integrated land use planning for soil conservation.

9. Answer: b

Explanation:

The correct answer is **All of these**.

★ **Key Points**

- Biodiversity :
 - Biodiversity refers to the different types of species including plants, bacteria, animals, and humans in one region or ecosystem.
 - It is also known as the variety and variability of life on Earth.
 - It is the most complex and significant aspect of our world.
 - A biodiversity hotspot is a region or ecosystem having a high value of biodiversity, a high number of endemic species, and having a high degree of threat i.e. measured in terms of habitat loss and fragmentation.
- Values of Biodiversity :

- Humans value biodiversity for a variety of purposes.
 - Many people believe that biodiversity has intrinsic value, meaning that each species has a value and a right to survive regardless of whether or not it is understood to have value to humans.
-

10. Answer: b

Explanation:

The correct answer is Decibel.

★ Key Points

- **Noise pollution is measured in decibels (dB)** with reference to a standard sound intensity of the following magnitude 1 pico watt per m².
 - The World Health Organization (WHO) defines noise above 65 decibels (dB) as noise pollution .
 - To be precise, noise becomes harmful when it exceeds 75 decibels (dB) and is painful above 120 dB .
 - As a consequence, it is recommended noise levels be kept below 65 dB during the day and indicates that restful sleep is impossible with nighttime ambient noise levels in excess of 30 dB.
 - Sound intensity is defined as the sound power per unit area. The usual context is the measurement of sound intensity in the air at a listener's location. The basic units are watts/m² or watts/cm².
-

11. Answer: d

Explanation:

The correct answer is Rabies.

★ Key Points

Disease	Caused by
Rabies	<ul style="list-style-type: none"> • It is caused by the rabies virus. • The virus is spread through the saliva of infected animals. • Infected animals can spread the virus by biting another animal or a person. • In rare cases, rabies can be spread when infected saliva gets into an open wound or the mucous membranes, such as the mouth or eyes. • A deadly virus spreads to people from the saliva of infected animals. • Rabies is usually transmitted through an animal bite, for example, from stray dogs. • Symptoms include fever, headache, excess salivation, muscle spasms, paralysis, and mental confusion. • Seek immediate medical attention after a bite or suspected bite. • There is no specific treatment for rabies. • Once symptoms appear, it's nearly always fatal. • A vaccine can prevent infection.
Typhoid	<ul style="list-style-type: none"> • It is caused by the bacterium SalmonellaTyphi. • It is usually spread through contaminated food or water.
Leukemia	<ul style="list-style-type: none"> • Leukemia is a blood cancer caused by a rise in the number of white blood cells in your body . • Those white blood cells crowd out the red blood cells and platelets that your body needs to be healthy.
Filaria	<ul style="list-style-type: none"> • Lymphatic filariasis, commonly known as elephantiasis , is a neglected tropical disease. • Infection occurs when filarial parasites are transmitted to humans through mosquitoes.

- Lymphatic filariasis is caused by infection with parasites classified as nematodes (roundworms) of the family Filariodidea
- Lymphatic filariasis impairs the lymphatic system and can lead to the abnormal enlargement of body parts , causing pain, severe disability.

12. Answer: a

Explanation:

The correct answer is Heart.

★ Key Points

- ECG records the rate of heartbeats.
 - ECG stands for Electrocardiogram .
- In ECG, electrodes are placed on the skin to note the normal working condition of the heart.
- ECG was first developed by Willem Einthoven.
- A normal ECG has 5 deflection waves P, Q, R, S, and T. Out of the P, R, and T waves are above the baseline and are called positive waves. The Q and S waves are below the baseline and are called negative waves.
- There are three types of ECT tests-
 - Resting ECG
 - Exercise ECG
 - 24 hour ECG

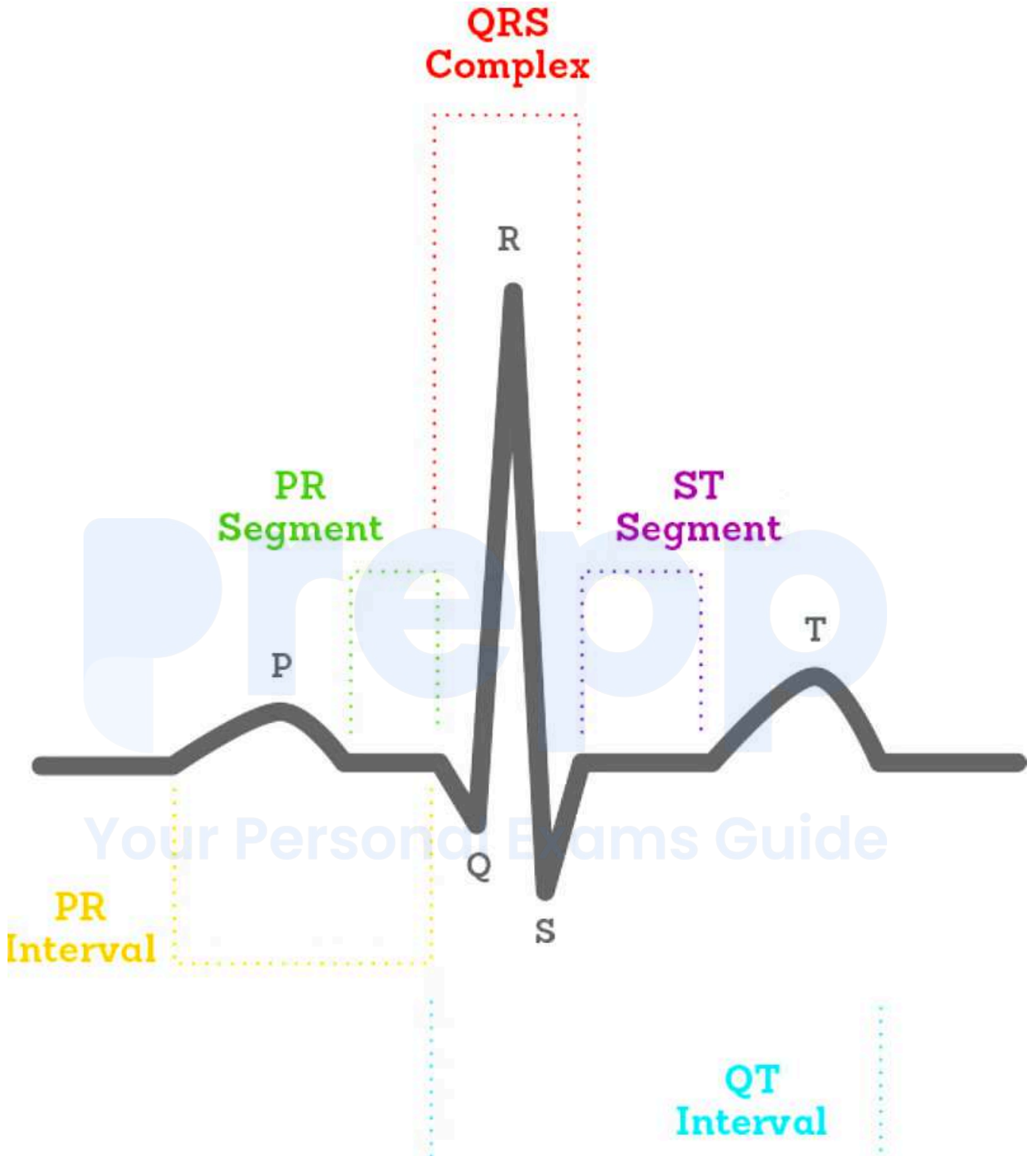

13. Answer: c

Explanation:

The correct answer is Isotopes.

- $^{12}_6\text{C}$ and $^{14}_6\text{C}$, ^1_1H and ^3_1H , $^{35}_{17}\text{Cl}$ and $^{37}_{17}\text{Cl}$ are examples of **Isotopes**.

★ Key Points

- Isotopes
 - Those elements that have the same atomic number but a different mass number are referred to as isotopes. Hence, Option 3 is correct.
 - Isotopes occur due to the presence of a different number of neutrons in elements having the same atomic number as mass number is the sum of the number of neutrons and protons.
 - Many but not all elements have isotopes.
 - The isotopes of hydrogen are protium (has one proton and no neutrons), deuterium (has one proton and one neutron), and tritium (has one proton and two neutrons).
 - The chemical properties of isotopes are the same because they have the same number of protons and hence the same number of electrons which determines the chemical properties of an element.

★ Additional Information

- Isobars
 - The atoms have the same mass number but a different atomic number.
 - For example, the atomic number of carbon and nitrogen is 6 and 7 respectively.
 - Carbon-14 an isotope of carbon has a mass number of 14 which is the same as that of nitrogen and hence carbon-14 and nitrogen are isobars.
- Isomers
 - In chemistry, isomers are molecules or polyatomic ions with identical molecular formulas – that is, the same number of atoms of each element – but distinct arrangements of atoms in space.
 - Isomerism is the existence or possibility of isomers.
 - Isomers do not necessarily share similar chemical or physical properties.
- Isotones

- Two nuclides are isotones if they have the same neutron number N , but different proton number Z .
- For example, boron-12, and carbon-13 nuclei both contain 7 neutrons, and so are isotones.
- Similarly, ^{36}S , ^{37}Cl , ^{38}Ar , ^{39}K , and ^{40}Ca nuclei are all isotones of 20 because they all contain 20 neutrons.

14. Answer: d

Explanation:

The correct answer is Citric acid and Malic acid.

★ Key Points

- Citric and malic acid are the main organic acids in tomatoes .
- Tomatoes are a good source of vitamin C and potassium.
- Other acids like oxalic acid and ascorbic acid are also present in tomatoes.

★ Mistake Points

- Tomato contains more than 10 different types of acids.
- We need to choose our answer from the options given.
- You may think that oxalic acid is the correct answer but since it is not given in options, we need to choose our answer from the given options.
- Thus, the correct answer is Citric acid and Malic acid.

★ Important Points

- Acid : An acid is any hydrogen-containing substance that is capable of donating a proton (hydrogen ion) to another substance.
- Acidic substances are usually identified by their sour taste .
- **Organic acid:** An acid made up of molecules containing organic radicals; e.g., acetic acid, citric acid, which contain the ionizable $-\text{COOH}$ group. These are found in fruits and vegetables.

★ Additional Information

- Lemon: **Citric acid**
- Tamarind: **Tartaric acid**
- Apple: Malic acid
- Buttermilk, Curd, Cheese: **Lactic Acid**

15. **Answer: c**

Explanation:

The correct answer is 2015.

★ Key Points

- The Paris Agreement is a legally binding international treaty on climate change . It was adopted by 196 Parties at COP 21 in Paris, on 12 December 2015 and entered into force on 4 November 2016.
- Its goal is to limit global warming to well below 2, preferably to 1.5 degrees Celsius , compared to pre-industrial levels.
- To achieve this long-term temperature goal, countries aim to reach global peaking of greenhouse gas emissions as soon as possible to achieve a climate-neutral world by mid-century.
- It is a landmark process because, for the first time, a binding agreement brings all nations into a common cause to undertake ambitious efforts to combat climate change and adapt to its effects.
- Implementation of the Paris Agreement requires economic and social transformation, based on the best available science .
- The Agreement works on a 5- year cycle of increasingly ambitious climate action carried out by countries. By 2020, countries submit their plans for climate action known as nationally determined contributions (NDCs).
- In their NDCs, countries communicate actions they will take to reduce their Greenhouse Gas emissions in order to reach the goals of the Paris Agreement. Countries also communicate in the NDCs actions they will take to build resilience to adapt to the impacts of rising temperatures .

The Paris climate agreement: key points

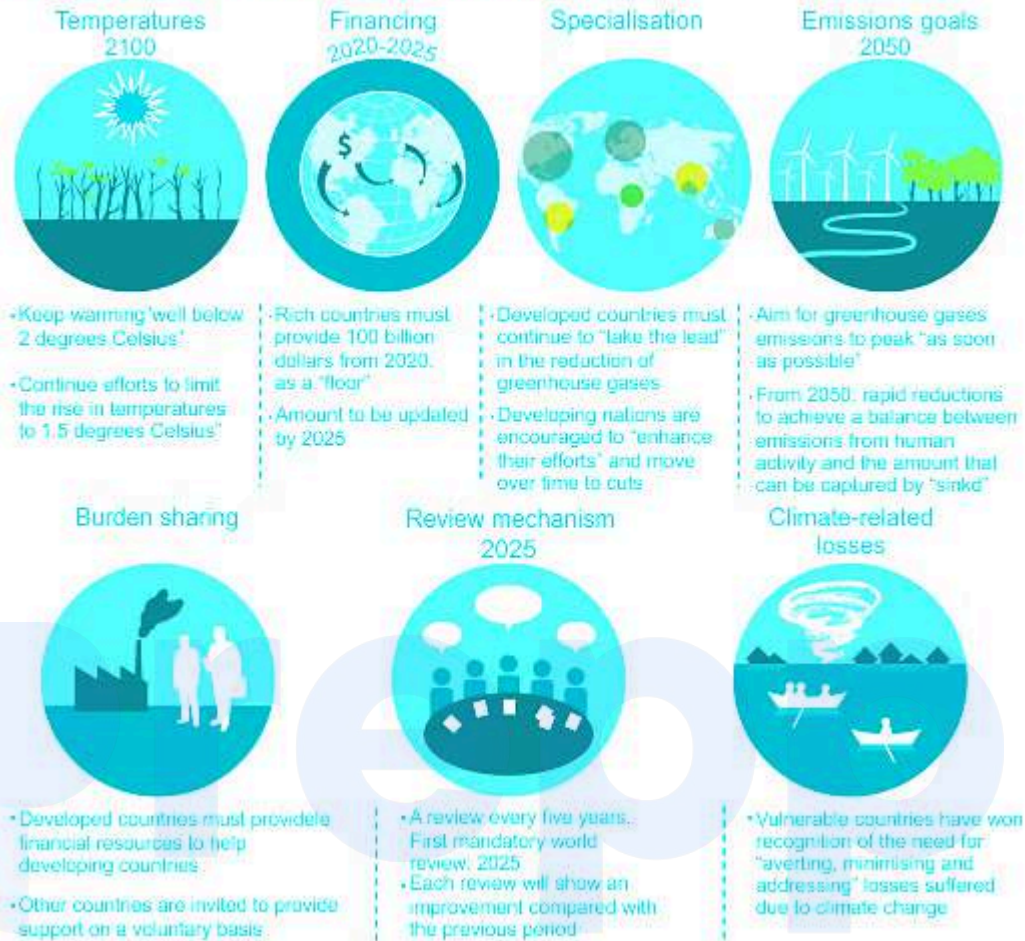

Your Personal Exams Guide

16. Answer: b

Explanation:

The correct answer is Formic acid – Milk.

★ Key Points

- Lactic Acid is present in milk.
- It does have a $\text{CH}_3\text{CH}(\text{OH})\text{COOH}$ molecular formula.
- It's strong white and miscible with water.
- Because of the presence of the carboxyl group adjacent to the hydroxyl group it is an alpha-hydroxy acid (AHA).

- It is produced by the fermentation of milk .

★ Important Points

- Formic acid is present in **ant bites** .
- The sting of an ant contains simple carboxylic acid, which is also known as formic acid.
- The same acid is present in the sting of wasps, bees, etc.
- The chemical formula of formic acid is H-COOH.

17. **Answer: d**

Explanation:

The correct answer is an Offshore patrol ship.

★ Key Points

- An offshore Patrol Vessels (OPV) for the Indian Coast Guard was launched and re-christened as Indian Coast Guard Ship 'Sarthak' .
- OPV Sarthak is the 4th in the series of five **OPVs**.
- It has been designed & built indigenously by Goa Shipyard Limited (GSL) in line with the Prime Minister's vision of 'Make in India'.
- The Ship is fitted with state-of-the-art Navigation and Communication equipment, sensor, and machinery.
- The 105 Metre ship displaces approximately 2350 tons and is propelled by two 9100 KW diesel engines designed to attain a maximum speed of 26 knots , with an endurance of 6000 Nautical Miles.

18. **Answer: a**

Explanation:

The correct answer is Lakshadweep.

★ Key Points

- Lakshadweep is the first Union Territory in India to be declared 100 % organic by the Ministry of Agriculture in 2020 .
 - The entire Lakshadweep group of islands has been declared as an organic agricultural area under the Participatory Guarantee System (PGS) of India.
 - All farming activity in the UT is carried out without the use of synthetic fertilisers and pesticides .
 - This provides access to safer food choices and makes agriculture a more environment -friendly activity.

★ Additional Information

- The Lakshadweep is the smallest union territory of India and its total surface area is just 32 km².
- Lakshadweep is an archipelago of 36 islands in the Arabian sea, located 200 to 440 km off of the mainland's southwestern coast.
- In Malayalam , Lakshadweep means " One lakh islands " .
- Malayalam is the official as well as the widely spoken native language in the territory .
- Kavaratti is the capital of the Union Territory Lakshadweep in India.

Your Personal Exams Guide



19. Answer: a

Explanation:

The correct answer is 4,2,1,3.

- The chronological events in order are
 1. Death of Ferozshah Mehta (1915)

2. Jallianwala Bagh Massacre (1919)
3. Appointment of Simon Commission (1927)
4. Mahatma Gandhi's Dandi March (1930)

★ Key Points

- Pherozeshah Merwanjee Mehta
 - He was an Indian Parsi politician and lawyer from Bombay.
 - He was one of the founding members and President of the Indian National Congress in 1890.
 - He died on 5 November 1915, in Bombay.
- Jallianwala Bagh Massacre
 - It was a massacre that happened on April 13, 1919 ,
 - in which British troops fired on a large crowd of unarmed Indians in an open space known as the Jallianwala Bagh in Amritsar in Punjab.
- Simon Commission
 - It was a commission appointed in November 1927 by the British Conservative government under Stanley Baldwin
 - It was tasked to report on the working of the Indian constitution established by the Government of India Act of 1919.
- Dandi March
 - On March 12, 1930 , Gandhi set out from his ashram, or religious retreat, at Sabarmati near Ahmedabad with several dozen followers on a trek of some 240 miles to the coastal town of Dandi on the Arabian Sea.

20. Answer: c

Explanation:

The correct answer is Vinayak Damodar Savarkar.

- Vinayak Damodar Savarkar founded the Abhinav Bharat Society.

★ Key Points

- Abhinav Bharat

- VD Savarkar or Vinayak Damodar Savarkar was born on May 28, 1883, in Bhagur, a village near Nashik in Maharashtra.
- Savarkar was also associated with the India House and founded the Free India Society.
- The airport at Port Blair in Andaman and Nicobar's capital was renamed Veer Savarkar International Airport in 2002.

★ Additional Information

- Vinayak Damodar Savarkar was born May 28, 1883, at Bhagur village of Nashik district in Maharashtra.
- He passed away on February 26, 1966, in Bombay.
- He was a nationalist and one of the most important figures of the Hindu Mahasabha ("Great Society of Hindus"), a Hindu nationalist organization and political party.
- He got the nickname 'Veer' at the age of 12 after performing a brave act.

21. **Answer: d**

Explanation:

The correct answer is 17.5.

★ Key Points

- India's population accounts for the world's 17.5 per cent. population. Hence option 3 is Correct.
- Of the total population of 1210.2 million, the number of males was pegged at 623.7 million and the population of females stood at 586.5 million.
- The percentage growth in 2001-2011 was 17.64.
 - For males, the growth rate was 17.19% and for females, it was 18.12%.
- Though the country's population is almost equal to the combined population of the U.S., Indonesia, Brazil, Pakistan, Bangladesh, and Japan put together [1214.3 million], the silver lining is that 2001-2011 is the first decade with the exception of 1911-1921 which has actually added lesser population compared to the previous decade.

- Among the States and Union Territories, Uttar Pradesh is the most populous state with 199 million people followed by Maharashtra at 112 million people and Lakshadweep is the least populated at 64,429 persons.

22. Answer: d

Explanation:

The correct answer is Satluj and Kali.

★ Key Points

- The Kumaon Himalayas lie in Uttarakhand and extend from the Satluj to the Kali river
- The Lesser Himalayas in Kumaon Himalaya is represented by the Mussoorie and Nag Tiba ranges.
- The Shiwalik in this region runs south of the Mussoorie range between the Ganga and the Yamuna rivers.
- The flat valleys between the Lesser Himalaya and the Shiwalik range are called 'doons' or 'Duns' of which Dehra Dun is the most famous.

★ Additional Information

- Western Himalayas:
 - It encompasses three physiographic provinces namely Kashmir Himalaya, Himachal Himalaya, and Kumaon Himalaya (Uttarakhand Himalayas).
 - The Ladakh plateau and the Kashmir valley are two important areas of the Kashmir Himalayan region.
 - In Himachal Himalayas, The Greater Himalaya is represented by the Zaskar range, the lesser Himalaya by Pir Panjal and Dhauladhar ranges, and the Outer Himalaya by the Shiwalik range.
 - The southern slopes are rugged, steep, and forested while the northern slopes are bare, gentle, and show plains with lakes.

★ Important Points

Rivers	Himalayan Range
Kali and Tista	Nepal Himalaya
Teesta and Dihang	Assam Himalayas
Indus and Satluj	Punjab Himalayas
Satluj and Kali	Kumaon Himalayas

23. Answer: a

Explanation:

The correct answer is Production of cereal crops.

★ Key Points

- The Green Revolution
 - The green revolution refers to the large increase in the production of food grains resulting from the use of high-yielding variety (HYV) seeds, especially for wheat and rice.
 - The use of these seeds required the use of fertilizer and pesticide in the correct quantities as well as a regular supply of water.
 - At independence, about 75 per cent of the country's population was dependent on agriculture.
 - Productivity in the agricultural sector was very low because of the use of old technology and the absence of required infrastructure for the vast majority of farmers.
 - India's agriculture vitally depends on the monsoon and if the monsoon fell short the farmers were in trouble unless they had access to irrigation facilities which very few had.
 - The stagnation in agriculture during the colonial rule was permanently broken by the green revolution.
 - This refers to the large increase in production of food grains resulting from the use of high-yielding variety (HYV) seeds, especially for wheat and rice.

- The use of HYV seeds required the use of fertilizer and pesticide in the correct quantities as well as a regular supply of water; the need for these inputs in correct proportions is vital.
- The farmers who could benefit from HYV seeds required reliable irrigation facilities as well as the financial resources to purchase fertilizer and pesticides.
- As a result, in the first phase of the green revolution (the approximately mid-1960s up to mid-1970s), the use of HYV seeds was restricted to the more affluent states such as Punjab, Andhra Pradesh, and Tamil Nadu.
- Further, the use of HYV seeds primarily benefited the wheat-growing regions only.
- A good proportion of the rice and wheat produced during the green revolution period (available as marketed surplus) was sold by the farmers in the market.
- As a result, the price of food grains declined relative to other items of consumption.
- The low-income groups, who spend a large percentage of their income on food, benefited from this decline in relative prices.
- The green revolution enabled the government to procure a sufficient amount of food grains to build a stock that could be used in times of food shortage.

Your Personal Exams Guide

24. Answer: d

Explanation:

The correct answer is Odisha.

★ Key Points

- Odisha is most likely to be affected by a cyclone because the east coast is more prone to cyclones and Odisha is situated on the East coast of India.
- **The reason for being more prone to the cyclone is:**
 - The temperature and salinity of the Bay of Bengal are more than the Arabian sea.

- Prevailing of Easterly Subtropical Jetstream.
- The Bay of Bengal is very active during the end of the monsoon (Oct to Dec) because a lot of freshwater mixes in it via great rivers Ganga Brahmaputra etc.

★ Additional Information

- Cyclone: A cyclone is a rotating low-pressure weather system with inward-spiralling winds, which spins clockwise in the southern hemisphere and anticlockwise in the northern hemisphere.
- The eastern coastal states are Tamil Nadu, Andhra Pradesh, Orissa and West Bengal.

25. Answer: c

Explanation:

The correct answer is Northern Railway Zone.

- North Zone is Indian Railways' largest Railway zone.

★ Key Points

- The Indian Railways are divided into 18 zones and 70 divisions.
- Southern Coast Railway will be the 18th railway zone with its headquarters at Visakhapatnam.
- The division of this zone will include Guntakal, Vijayawada, Guntur, divisions that currently serve as divisions in the South Central Railway.
- Indian rail lines have four types: Broad Gauge; Meter Gauge, Narrow Gauge, and Standard Gauge.
- The first train in India was started from Bombay to Thane (34 Kms) by Lord Dalhousie on April 16, 1853.
- Indian Railways was **nationalized in 1951** and is now Asia's largest rail network and the world's second-largest.
- The Southern Railway zone was the first zone to be established at 9,654 kilometres (5,999 mi).

- It was founded on 14 April 1951 by the merger of the Madras and Southern Maharashtra Railway, South Indian Railway, and Mysore State Railway, this zone's economic and geographic factors facilitated an early integrated network.

26. Answer: b

Explanation:

The positions of the letters according to the English alphabet series:

Alphabets	A	B	C	D	E	F	G	H	I	J	K	L	M
Positional value	1	2	3	4	5	6	7	8	9	10	11	12	13
Positional value	26	25	24	23	22	21	20	19	18	17	16	15	14
Alphabets	Z	Y	X	W	V	U	T	S	R	Q	P	O	N

The pattern for this code is as follows;

$$(\text{Positional Value of letter})^3 = \text{Number}$$

In F : 216 →

$$F = 6$$

$$6^3 = 216$$

Similarly;

In L : ? →

$$L = 12$$

$$12^3 = 1728$$

Hence, "1728" is the correct answer.

27. Answer: a

Explanation:

The positions of the letters according to the English alphabet series:

Alphabets	A	B	C	D	E	F	G	H	I	J	K	L	M
Positional value	1	2	3	4	5	6	7	8	9	10	11	12	13
Positional value	26	25	24	23	22	21	20	19	18	17	16	15	14
Alphabets	Z	Y	X	W	V	U	T	S	R	Q	P	O	N

The pattern for this code is as follows;

Positional values of the letters.

In GANGA →

G = 7

A = 1

N = 14

G = 7

A = 1

GANGA = 711471

Similarly;

In SARJU →

S = 19

A = 1

R = 18

$$J = 10$$

$$U = 21$$

$$\text{SARJU} = 191181021$$

Hence, "191181021" is the correct answer.

28. Answer: c

Explanation:

As per the given information;

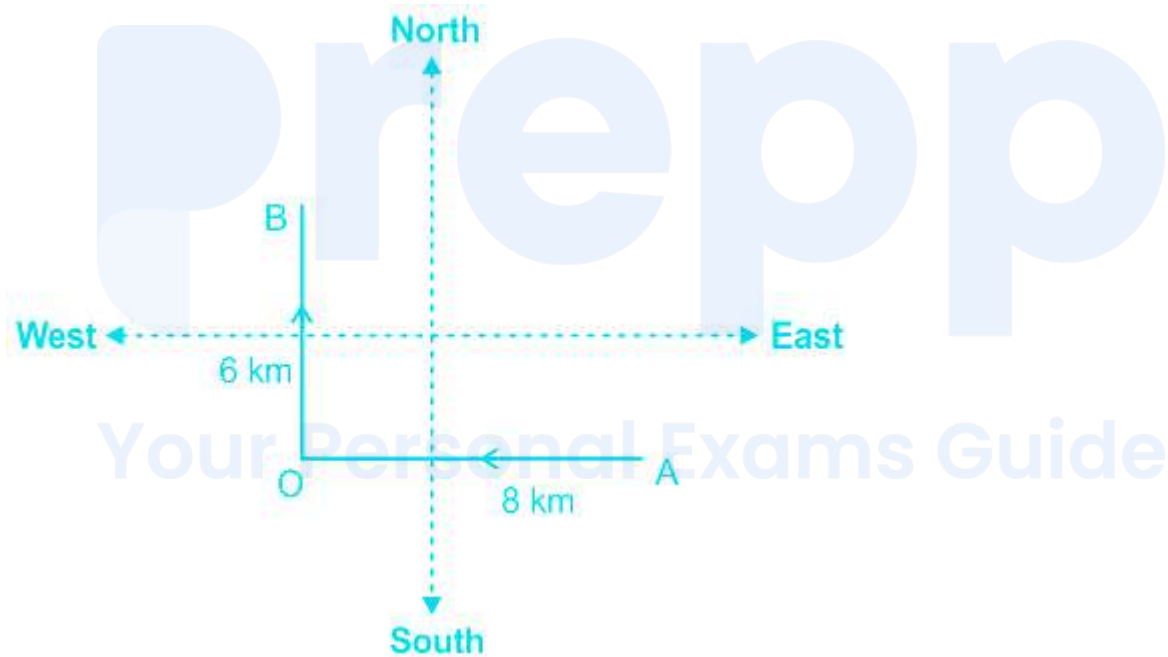

$$\text{Distance between A and B} = \sqrt{AO^2 + OB^2}$$

$$AB = \sqrt{8^2 + 6^2}$$

$$AB = \sqrt{64 + 36}$$

$$AB = \sqrt{100}$$

$$AB = 10 \text{ km}$$

Hence, The man is 10 km from his starting point.

29. Answer: c

Explanation:

Time = 2 : 30

$$\text{Angle} = \theta = |(60 \times \text{hour} - 11 \times \text{minute})/2|^\circ$$

And another angle = $(360 - \theta)^\circ$

$$\therefore \theta = |(60 \times 2 - 11 \times 30)/2|^\circ$$

$$= |(120 - 330)/2|^\circ$$

$$= (210/2)^\circ$$

$$= 105^\circ$$

And another angle = $(360 - \theta)^\circ = (360 - 105)^\circ = 255^\circ$

In the option, 105° is given.

Hence, ' 105° ' is the correct answer.

30. Answer: d

Explanation:

The city of Prayagraj is among the largest cities of Uttar Pradesh and is situated at the confluence of three rivers- **Ganga, Yamuna, and the invisible Saraswati.**

Similarly;

Ayodhya is a city **situated** on the banks of the holy **river** Saryu.

Hence, "Saryu" is the correct answer.

31. Answer: a

Explanation:

The correct answer is Alluvial.

★ Key Points

prepp

Your Personal Exams Guide

Soil Type	Transporting Agent
Alluvial Soil	Running Water
Lacustrine Soil	Fresh Still water of lakes
Marine Soils	Seawater
Aeolian Soils	Wind
Colluvial Soils	Gravitational Force
Glacial Soil	Glaciers or ice
Loess Soil	Windblown silt
Peat Soil	Decomposition of organic matter
Marl Soil	Decomposition of aquatic life
Tuff Soil	Transported by water or wind
Bentonite Soil	Volcanic ash

32. Answer: a

Explanation:

The correct answer is Food chain.

★ Key Points

- Food Chain
 - Transfer of food energy from green plants (producers) through a series of organisms with repeated eating and being eaten link is called a food chain.
 - E.g. Grasses → Grasshopper → Frog → Snake → Hawk/Eagle.
 - Each step in the food chain is called a trophic level.
 - A food chain starts with producers and ends with top carnivores.
 - The trophic level of an organism is the position it occupies in a food chain.
 - A food chain illustrates the order in which a chain of organisms feeds upon each other.
 - Food chains are found within the populations of a species.
 - A food chain illustrates the numbers of each organism that is eaten by others.

Your Personal Exams Guide

33. Answer: d

Explanation:

The correct answer is Benthic.

★ Key Points

- **The benthic zone** is the ecological region at the lowest level of a body of water
 - It starts at the shoreline and continues down until it reaches the floor, encompassing the sediment surface and subsurface layers.

- Although this zone may appear barren, it plays a vital role in the health of aquatic ecosystems .
- Tiny, microscopic benthic organisms live in this zone and act as a source of food for bottom-feeding animals.
- Benthic organisms are very important as they are good indicators of water quality.

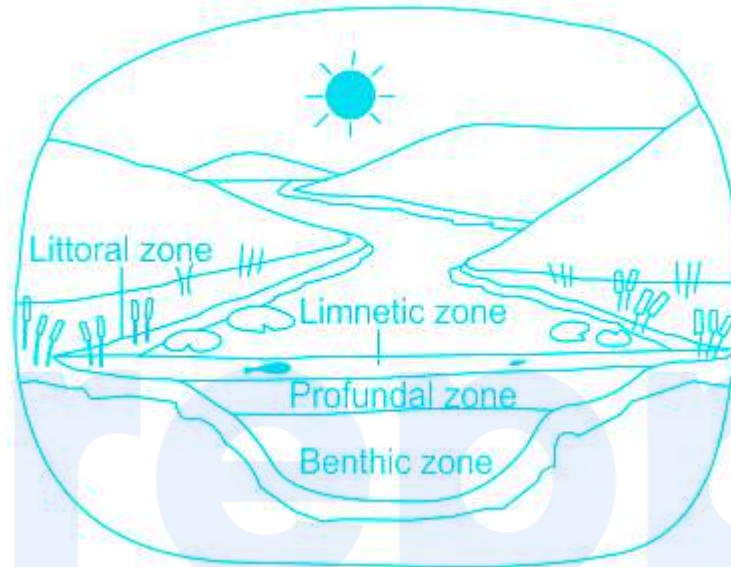

★ Additional Information

Your Personal Exams Guide

Lentic	<ul style="list-style-type: none"> • Lentic ecosystems are those water bodies whose water is still. • These ecosystems range in size from very small ponds or pools that may be temporary, to large lakes. • Example: ponds, marshes, pools, ditches, lakes, and swamps.
Pelagic	<ul style="list-style-type: none"> • Aquatic animals living not near the bottom of the shore, coasts, open oceans, and lakes are called Pelagic.
Lotic	<ul style="list-style-type: none"> • Lotic ecosystems are those water bodies whose water is flowing. • These ecosystems can vary in size dramatically from small trickling streams to mile-wide rivers that travel for thousands of miles. • Example: rivers, streams, canals and springs.

34. Answer: c

Explanation:

The correct answer is **4800 Megawatt hour**.

★ Key Points

Power = 200 MW

Power = Energy/Time

Therefore, Energy = Power * Time

Energy = 200MW * 24h

Energy = 4800MWh

35. Answer: c

Explanation:

The correct answer is 28 th February.

★ Key Points

- 28th February is celebrated as National Science Day.
- Indian Scientist Sir C. Venkata Raman on this day in 1928, discovered a phenomenon of scattering of photons which was later known as the 'Raman Effect'.
- In 1930, he got Nobel Prize for this exceptional discovery.
- The National Council for Science and Technology Communication (NCSTC) in 1986 requested the Government of India to designate 28 February as National Science Day.
- The government of India accepted and announced the day as National Science Day in 1986.
- The theme for National Science Day 2021 is 'Future of STI: Impact on Education Skills and Work'.

Your Personal Exams Guide

36. Answer: a

Explanation:

The correct answer is Goa.

★ Key Points

- Jal Jeevan Mission
 - It aims to provide piped drinking water to all rural households by 2024.
 - It aims to provide 55 litres of tap water per person per day to all households by 2024.

- **Goa** has become the first 'Har Ghar Jal State' to provide 100% household tap connections in rural areas.
- The **Jal Shakti Ministry** is the nodal ministry for the implementation of the scheme.

★ Additional Information

- Jal Jeevan Mission:
 - Jal Jeevan Mission (JJM) envisages a supply of 55 litres of water per person per day to every rural household through Functional Household Tap Connections (FHTC) by 2024 .
 - JJM focuses on integrated demand and supply-side management of water at the local level.
 - Creation of local infrastructure for source sustainability measures as mandatory elements, like rainwater harvesting, groundwater recharge and management of household wastewater for reuse, would be undertaken in convergence with other government programmes/schemes.

37. Answer: d

Explanation:

The correct answer is Tamil Nadu.

★ Key Points

- Thai poosam is a festival celebrated by the Tamil Hindu community mainly in south India.
- Thai Poosam festival is dedicated to Lord Muruga.
- Lord Muruga is the son of Shiva and Parvati.
- The word Thaipooam is a combination of the name of a month and the name of a star.
- The festival is also observed in Kerala as Thaipooam.
- It is believed that Thaipooam marks Lord Muruga's birthday.
- It is a celebration of the victory of good over evil.

38. Answer: a

Explanation:

The correct answer is Uttar Pradesh.

★ Key Points

- On January 6, 2021, the Uttar Pradesh government launched a special program called the 'Kisan Kalyan Mission' to double the state's farmers' income. In every development block of all 75 districts, the 3-week long campaign for farmers' welfare will be coordinated.
- Uttar Pradesh's Chief Minister, Yogi Adityanath, launched the mission from the Lucknow development block of Sarojini Nagar.
- Several state government departments, such as Horticulture, Mandi Parishad, animal husbandry, food and supply for sugarcane, fisheries, and Panchayati Raj, will work together under the mission to be launched by the government of Uttar Pradesh.

39. Answer: a

Explanation:

The correct answer is Shuggie Bain.

★ Key Points

- Douglas Stuart has won the Booker Prize for his novel ' Shuggie Bain '.
- 'Shuggie Bain' is Douglas' debut novel that has been published in 2020.
- It is an autobiographical novel that tells the story of his mother and him and is set in Glasgow of 1980s .
- The Novel is about a boy supporting her mother suffering for alcoholism, marriage breakdown and poverty.

- The novel was rejected by 32 publishers before being published by UK based Picador Publishers.

★ Additional Information

- About the Booker Prize :
 - It is literary award given for the novels written in English and Published in either England or Ireland .
 - The prize was constituted in the year 1969 by Booker McConnell Limited Company .
 - The awardee is presented with a reward of 50,000 Euros .
 - The first winner of this prize was PH Newby who won it for his novel 'Something to Answer for'.
 - Since 2019, The award is being presented by 'Crankstart' .
- Indian winners of Booker Prize :
 - VS Naipaul: On a Free State.
 - Salman Rushdie: Midnight' s Children
 - Arundhati Roy: The god of small things
 - Kiran Desai: The inheritance of Loss
 - Aravind Adiga: The White Tiger

40. Answer: c

Explanation:

The correct answer is Maidan river.

★ Key Points

- A Memorandum of Understanding (MoU) on Video-Teleconferencing (VTC) was signed by India and Afghanistan to build the Shahtoot Dam also known as Lalander Dam.
- Shahtoot Dam in Afghanistan , on **Maidan river** a tributary of the Kabul River.
- The initiative, costing nearly \$300 million, is part of India and Afghanistan's New Development Partnership.

- The MoU was signed between Dr Jaishankar, Minister of Foreign Affairs, and Mr Hanif Atmar, Minister of Foreign Affairs of Afghanistan, in the presence of Shri Narendra Modi, Prime Minister of India, and Dr Mohammad Ashraf Ghani, President of Afghanistan.
- The Shahtoot Dam will meet Kabul City's healthy drinking water needs, provide irrigation water to nearby areas, rehabilitate the current irrigation and drainage network, assist in the area's flood control and management efforts, and also provide the region with electricity.
- After the India- Afghanistan Friendship Dam [Salma Dam], which was inaugurated in June 2016, this is the second major dam being constructed by India in Afghanistan.

41. Answer: b

Explanation:

The correct answer is 1 July 2017.

★ Key Points

- Goods and Service Tax(GST) was implemented in India on 1st July 2017 by then Finance Minister Arun Jaitley.
- Goods and Service Tax(GST):
 - GST is an indirect tax used in India on the supply of goods and services.
 - It is a destination-based tax.
 - Goods and services are divided into five different tax slabs for collection of tax- 0%, 5%, 12%, 18%, and 28%.
 - GST Council is the governing body of GST having 33 members.
 - The council is headed by the union finance minister assisted by the finance ministers of all the states of India.

★ Additional Information

- The 101st Constitutional (One Hundred and First Amendment) Act, 2016 introduced a national Goods and Services Tax (GST) in India on 1 July 2017.

- The Goods and Services Tax (GST) is a Value Added Tax (VAT) intended to establish a systematic indirect tax levy on the production, sale, and use of products and services at the national level.
- CGST, IGST, UTGS, and SGST Compensation Act passed at Loksabha on 29 March 2017 .
- The Constitution (One Hundred and Twenty-Second Amendment) Bill, 2014 was introduced on 19 December 2014 by Finance Minister Arun Jaitley in the Lok Sabha and passed on 6 May 2015 by the House.

42. Answer: c

Explanation:

The correct answer is Madras.

★ Key Points

- Madras High Court has jurisdiction over Tamil Nadu and the Union Territory of Puducherry.
- Pondicherry, officially known as Puducherry, is the capital and the most populous city of the Indian union territory of Puducherry.
- The city is in the Puducherry district on the southeast coast of India and is surrounded by the state of Tamil Nadu.

★ Important Points

- The High Court of Kerala is the highest court in the Indian state of Kerala and in the Union Territory of Lakshadweep. It is located in Kochi.
- The Madras High Court is the second oldest High Court of India after the Calcutta High Court in Kolkata. It is located in Chennai, Tamil Nadu.

43. Answer: a

Explanation:

The correct answer is Dyarchy in the center.

★ Key Points

- **Government of India Act 1935**
 - Government of India 1935 was a second milestone towards a completely responsible government in India. It had the following provisions:
 - It provided for the **establishment of an All-India Federation consisting of provinces and princely states** as units.
 - However, this provision never came into force.
 - It abolished dyarchy in the provinces (brought by the Government of India Act 1919) and introduced 'provincial autonomy' in its place.
 - It provided for the adoption of dyarchy at the Centre. Hence dyarchy at the center is a feature of the GOI Act 1935. *Hence, statement 1 is incorrect.*
 - It introduced bicameralism in six out of eleven provinces .

★ Additional Information

- **The Government of India Act 1919 was an Act of the Parliament of the United Kingdom.**
 - Government of India Act, 1919 also known as Montagu-Chelmsford Reforms which came into force in 1921.
 - It was instituted in the British Indian polity to introduce the Diarchy, i.e., rule of two which means executive councillors and popular ministers.
 - The Central Legislature was made more powerful and more representative by this Act.

44. **Answer: a**

Explanation:

The correct answer is Raja Raja Pratham.

★ Key Points

- **Brihadeshwara Temple of Tanjore** was built by Raja Raja Chola I aka Raja Raja Pratham.
- **Key facts about Brihadeshwara Temple:**
 - Brihadeshwara Temple, Thanjavur is in Tamil Nadu .
 - It is a Hindu Temple dedicated to Lord Shiva.
 - It is one of the largest Temple in the southern part of India.
 - It is built between 1003 and 1010 AD by Raja Raja Chola I in Dravidian architecture style.
 - It is on the list of UNESCO World Heritage Site.
 - It is also called Dakshina Meru which simplifies “Meru of South”.





45. Answer: c

Explanation:

The correct answer is Entrepreneurship Development.

★ Key Points

- About the Atal Innovation Mission (AIM):
 - The Atal Innovation Mission (AIM) is a flagship initiative set up by the NITI Aayog to promote innovation and entrepreneurship across the length and breadth of the country.
 - AIM's objectives are to create and promote an ecosystem of innovation and entrepreneurship across the country at school, university, research institutions, MSME and industry levels.
 - Initiatives of Atal Innovation Mission (AIM):
 - Atal Tinkering Labs - at the school level
 - Atal Incubation Centres - "An ecosystem of Startups and Entrepreneurs"
 - Atal Community Innovation Centres - serving Unserved and Under-Served regions of India

- Atal New India Challenges – Product and Service Innovations with National Impact
- ARISE ANIC challenges – to stimulate startup/ MSME industry innovation
- Mentor of Change (Mentorship and Partnerships – with Public, Private sector, NGOs, Academia, Institutions)

46. Answer: d

Explanation:

The Correct Answer is Madhya Pradesh.

★ Key Points

- The total forest cover of MP is 77,414 sq km.
- In terms of area, Madhya Pradesh has the largest forest cover in the country followed by Arunachal Pradesh, Chhattisgarh, Odisha, and Maharashtra.

★ Important Points

- In terms of forest cover as a percentage of their total geographical area, the top five states are
 - Mizoram (85.41 percent)
 - Arunachal Pradesh (79.63 percent)
 - Meghalaya (76.33 percent)
 - Manipur (75.46 percent)
 - Nagaland (75.31 percent).

47. Answer: b

Explanation:

The correct answer is Narmada.

★ Key Points

- River Narmada does not form a delta.
- River Narmada:
 - The Narmada is the westward flowing river of Peninsular India.
 - Source: The Narmada rises from the western flank of Amarkantak plateau in the state of Madhya Pradesh.
 - Mouth: The Narmada river drains into the Gulf of Khambat (the Arabian Sea) near Bharuch in the state of Gujarat.
 - The river flows in a rift valley between the Vindhyas in the north and the Satpura in the south.
 - The river forms a picturesque gorge in marble rocks.
 - The Narmada forms the Dhaundhar waterfalls, southwest of Jabalpur.
 - It forms the traditional boundary between North India and South India.
 - Peninsular rivers, such as the Narmada and the Tapi form estuaries.

Most of the major rivers of the peninsula such as the Mahanadi, the Godavari, the Krishna and the Cauvery flow eastwards and drain into the Bay of Bengal. These rivers make deltas at their mouths. Hence, only Narmada from the list does not form delta.

48. Answer: d

Explanation:

The correct answer is March 1946.

★ Key Points

- Cabinet Mission (1946):
 - The Cabinet Mission came to India in 1946.
 - It was launched by the British Government in March 1946 to discuss plans for the transfer of power from the British Raj to Indian leadership.
 - The members of the mission were:
 - Lord Patrick-Lawrence: The Secretary of State for India.
 - Sir Stafford Cripps: President of the Board of Trade

- A.V. Alexander: First Lord of the Admiralty.
- On 22nd January 1946, the decision to send Cabinet Mission was taken and on 19th February 1946, the British PM C.R Attlee Government announced in the House of Lords about the mission and the plan to quit India.
- The mission made its own proposals, after inconclusive dialogue with the Indian leadership, seeing that the Congress opposed Jinnah's demand for a Pakistan comprising six full provinces.
- The mission proposed a complicated system for India with three tiers: the provinces, provincial groupings and the centre.
- The centre's power was to be confined to foreign affairs, defence, currency and communications.
- The provinces would keep all the other powers and be allowed to establish three groups.

49. Answer: d

Explanation:

The correct answer is Rajya Sabha.

★ Key Points

- The Vice-President acts as the ex-officio chairman of Rajya Sabha .
- In the absence of the President, the Vice-President acts as President only for a maximum period of six months .
- The Vice-President shall be ex-officio Chairman of the Council of States and shall not hold any other office of profit .
- Article 70 states that the discharge of the President's functions in other contingencies .

★ Additional Information

- The articles (63-71) are related to the Vice President .
- The post of Vice President was taken from the USA .
- The minimum age should be 35 years for the post of Vice President.

- The election of the Vice President is mentioned in Article 66.
 - No State Legislative Assembly and State Legislative Council take part in the Vice president Election.
-

50. Answer: d

Explanation:

The correct answer is 29.

★ Key Points

- 11th Schedule:
 - The 11th Schedule of the Indian Constitution was added in 1992 by the 73rd Constitution Amendment Act.
 - The 11th Schedule of the Indian Constitution contains 29 subjects.
 - It covers topics such as Panchayat's powers, rural development, poverty alleviation, market, roads and drinking water, etc.

★ Additional Information

- The Eleventh Schedule of the Constitution of India consists of article 243G .
 - Article 243G of Constitution of India "Powers, authority and responsibilities of Panchayats"
 - The 11th Schedule of the Indian Constitution:
 - The 11th Schedule of the Indian Constitution was added in 1992 by the 73rd Constitution Amendment Act.
 - This schedule contains 29 subjects.
 - This schedule covers important topics such as Panchayat's powers, rural development, poverty alleviation, market, roads and drinking water etc.
 - It is expected that the subjects covered under the eleventh schedule of the Indian constitution are made to ensure the development of rural India.
-

51. Answer: a

Explanation:

Explanation:

- The four chambers of the heart are two atria and two ventricles.
- The four chambers are present in birds and mammals.
- Reptiles and amphibians usually have 3 chambered hearts.

★ Additional Information

- The increasing number of chambers of the heart signifies the evolution in living beings.
- Chambered helps in complete separation of oxygenated blood from de-oxygenated blood.
- The right ventricle pumps blood to the lungs, while the left ventricle pumps blood to the rest of the body.

52. Answer: c

Explanation:

Concept-

- The five-kingdom system was proposed by R.H. Whittaker .
- The kingdom defined by him was named- Monera, Protista, Fungi, Plantae, Animalia.
- Kingdom Animalia is divided into sub-groups which is known as Phylum.
- There are 11 phyla in the kingdom Animalia.
 - Porifera, Coelenterata, Ctenophora, Platyhelminthes, Aschelminthes, Annelida, Arthropoda, Mollusca, Echinodermata, Hemichordata, Chordata.
- Mammals are the class of phylum Chordata.

- Mammals are found in a variety of habitats – polar ice caps, deserts, mountains, forests, grasslands, and dark caves.
- Some of them have adapted to fly or live in water.
- They have two pairs of limbs, adapted for walking, running, climbing, burrowing, swimming, or flying.
- Mammals are divided into 3 types- Prototherians, Metatherians, and **Eutherians**.
- **Orders of eutherians are 16.**
- Some important orders names are - **Chiroptera, Rodentia, Lagomorpha, Carnivora, Cetacea, Proboscida, Artiodactyla, Perissodactyla, Primates.**

Explanation-

- **Cetacea** is the order of eutherians animals.
- These animals are marine animals i.e. **completely aquatic**.
- Their forelimbs were modified into **flippers for swimming** and Hindlimbs were absent.
- A thick heat resistance layer of adipose tissue is present just beneath the skin, that is called **blubber**.

Therefore Cetacea order of the class mammalian is completely aquatic.

Carnivora

★ Additional Information

- Smart, strong, and carnivore animals.
- The Upper last premolar and lower first molar are specialized for tearing the flesh, these are called carnassial teeth.
- Digitigrade locomotion is present.
- Examples of carnivores are Panthera leo, Canis familiaris, etc.

Rodentia

- It is the biggest order in mammals.
- These are small, terrestrial, herbivore, or omnivore animals.
- Incisor teeth grow continuously in these animals and canines are absent, empty space of canine is called diastema.

- Examples of Rodentia are Rattus rattus, Funambulus, etc.

53. Answer: a

Explanation:

The correct answer is Epidermis.

Explanation:

Epidermis-

- The **outermost layer of the epidermis** is known as the **stratum corneum**.
- Stratum corneum consist dead cells (corneocytes).
- The cells of the Stratum corneum are cornified.
- **Keratin** is a protein that is found in the epidermis and is **responsible for the formation of many skin structures**.
- So, the epidermis outermost layer stratum corneum is **responsible for the formation of nails, claws, hoofs, horns, hair, and feathers**.
- The main function of the stratum corneum is to protect the skin and the underlying tissue from dehydration, chemical and mechanical damage.

Thus, *the nails, claws, hoofs, and horns are developed from Epidermis*.

Your Personal Exams Guide

54. Answer: c

Explanation:

The correct answer is Vitamin K.

- Vitamin K is most commonly used for blood clotting problems or for reversing the blood-thinning effects of warfarin.
- Vitamin K is a vitamin found in leafy green vegetables, broccoli, and Brussels sprouts.

★ Additional Information

Vitamin E

- Vitamin E is a series of organic compounds consisting of various methylated phenols.
- Vitamin E deficiency causes neurological problems due to poor nerve conduction.
- It has been linked to Age-related macular degeneration (AMD), Alzheimer's disease.

Vitamin A (Retinol):

- Vitamin A is required in the production of rhodopsin, the visual pigment used in low light levels.

Vitamin C (Ascorbic Acid):

- Ascorbic acid is found in plants and animals where it is produced from glucose.
- Humans are unable to make ascorbic acid.

55. Answer: d

Explanation:

Concept-

Adaptation

- **Adaptation** is a feature of the organism (morphological, physiological, behavioral) which helps them to survive and reproduce in their habitat.
- **It** takes place in response to changes in the environment, or relationship to other organisms.
- Some examples: The fur of Polar bears gives them protection from cold weather, the hump of camel helps them in surviving without food in the desert areas.

Explanation -

- **Fossorial adaptation** occurs in the animals leading an underground mode of life.
- They have **digging organs** and they dig for food, or for shelter.
- They were **primitive** and defenseless.
- The modified head is small and tapers anteriorly to form a burrowing snout.
- The common **examples** are Amphibia, Sphenodon, snakes, and limbless-lizards, burrowing owls (Birds), etc.

Therefore the animals with digging or burrowing habits show fossorial adaptation.

Scansorial adaptation

★ Additional Information

- 'Scansorius' means capable of climbing and 'arboreus' means 'of a tree'.
- Modification for leading life on the walls, rocks, branches of the trees is called scansorial adaptation.

Volant adaptation

- Volant adaptation is defined as the animals that spend most of their time in the air, i.e., flying.
- The environment, i.e., the air is characteristically homogeneous and lighter than any other habitat.

Cursorial adaptation

- A cursorial organism is one that is adapted specifically to run.
- An animal can be considered cursorial if it has the ability to run fast (e.g. cheetah) or if it can keep a constant speed for a long distance.

56. Answer: b

Explanation:

Concept-

- ELISA means **Enzyme-Linked Immuno -sorbent Assay** .
- **ELISA** techniques serve the purpose of early diagnosis.
- **ELISA** is based on the principle of **antigen -antibody interaction** .
- Infection by a pathogen can be detected by the presence of **antigens** (proteins, glycoproteins, etc.) or by detecting the **antibodies** synthesized against the pathogen.

Explanation-

- **ELISA** uses an enzyme to detect the binding of antigens and antibodies.
- The enzyme converts a colorless substrate to a colored product, indicating the presence of Ag: Ab binding.
- An **ELISA** can be used to detect either the presence of Antigens or antibodies in a sample depending on how the test is designed.
- **ELISA** was developed in 1970 and became rapidly accepted.
- **ELISA** is used for the diagnosis of AIDS.

Therefore the working principle of ELISA is antigen-antibody interaction.

★ Additional Information

- **Phagocytic process:** Phagocytosis is a process for ingesting and eliminating materials, including, foreign substances, and apoptotic cells, etc.
- **Amplification process :** PCR is a method for amplifying a specific region of DNA molecule without the requirement for time-consuming cloning procedures.
- **Magnification process :** Magnification is for enlarging the apparent size.

57. Answer: a

Explanation:

Concept -

- Bt toxin is produced by a bacterium called **Bacillus thuringiensis (Bt for short)**.
- **Bt toxin** gene has been cloned from the bacteria and been expressed in plants to provide resistance to insects without the need for insecticides, in effect

creating a bio-pesticide.

- **Examples** are Bt cotton, Bt corn, rice, tomato, potato, and soybean, etc.

Explanation-

- **B acillus thuringiensis** , produces **crystals** (Cry) protein.
- This **Cry** protein is a toxin to Larvae of certain insects.
- Each **Cry** protein is toxic to a different group of insects.
- The gene encoding cry protein is called **the "cry gene"**.
- This **Cry protein was** isolated and transferred into several crops.
- A crop expressing a cry gene is usually resistant to the group of insects for which the concerned **Cry protein is toxic**.

Therefore Code of the Bt toxin gene is cry.

58. Answer: a

Explanation:

Explanation:

Photosynthesis

- It is the process of the preparation of food by plants in presence of sunlight.
- **Oxygen is released in the process and not required for it.**
- Following reaction takes place during the reaction.



Respiration

- The carbohydrate produced in the process is burnt in presence of oxygen and energy is released.
- So oxygen is required in the process.



Glycolysis

- Glycolysis is the process through which glucose is transformed into pyruvate or pyruvic acid. During this process ATP or Adenosine Triphosphate is also formed which is known as the “molecular unit of energy currency”.
- Glycolysis can occur with or without oxygen .
- In the presence of oxygen, glycolysis is the first stage of cellular respiration.
- In the absence of oxygen , glycolysis allows cells to make small amounts of ATP through the process of fermentation.

Electron Transport System

- The metabolic pathway through which the electron passes from one carrier to another is called the electron transport system (ETS) and it is present in the inner mitochondrial membrane .
- During the ETS $\text{NADH} + \text{H}^+$ and FADH_2 get oxidized to release and utilize the energy stored in them.
- This is accomplished when they are oxidised through the electron transport system and the electrons are passed on to O_2 resulting in the formation of H_2O .

So the correct option is photosynthesis.

59. Answer: b

Explanation:

Concept:

- Mycorrhizae is a symbiotic association between a fungus and roots of higher plants.
- The term mycorrhiza refers to the role of the fungus in the plant’s rhizosphere, its root system.
- Mycorrhizal fungi allow plants to draw more nutrients and water from the soil.
- They also increase plant tolerance to different environmental stresses.
- They play a major role in the soil aggregation process and stimulate microbial activity.
- Fungistatic: It is a process that stops the growth of fungus.

- Mutualism: It is an interaction between two organisms in which both are being benefitted.
- Amensalism: It is a process in which one organism is harmed and the other has no effect.

prepp

Your Personal Exams Guide

Interaction	Species X	Species Y
Mutualism	+	+
Commensalism	+	0
Predation	+	-
Herbivory	+	-
Parasitism	+	-
Amensalism	0	-
Competition	-	-
Neutralism	0	0

Classic categories of direct effects in ecological communities

The sign (+, -, 0) represents the net effect of one species on the other species, either positive, negative, or neutral

Conclusion:

In Mycorrhizae, both plant and fungus are benefitted. So, it is an example of Mutualism

★ Additional Information

Mycorrhiza is of two types:

1. Ectomycorrhiza - In this, the fungus forms a covering around the plant's roots. In this way, a layer like structure is formed on the surface of the roots, which is called pseudoparenchymatous sheath. Ex - Pinus , Abies , Eucalyptus and Oak
2. Endomycorrhiza - In this the fungus does not form a layer on the roots of plants. They enter intracellularly in the roots. Intracellular fungal hyphae form branched structures in cells of roots called " arbuscule " and unbranched structures called vesicles so these are also called Vesicular arbuscular mycorrhizal (VAM) . Ex - Orchids

60. Answer: c

Explanation:

Concept:

- Nitrogen Cycle:
 - The Nitrogen Cycle describes how Nitrogen moves between various components - plants, animals, bacteria, air, and soil.
 - The various processes involved in the Nitrogen cycle are fixation, nitrification, assimilation, ammonification, and denitrification.
- Denitrification:
 - Nitrification is the process of converting ammonium ions into nitrates or nitrites.
 - However, certain denitrifying bacteria in soil, like Pseudomonas and **Thiobacillus**, convert some of the nitrates back into nitrogen gas. This process is called Denitrification.
 - This process is the opposite of nitrification.
 - This process is the last stage in the Nitrogen cycle and occurs in the absence of Oxygen.

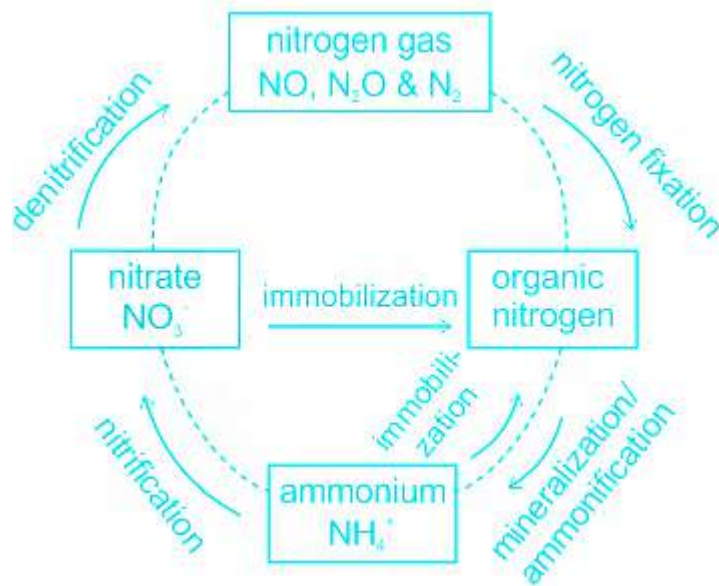

Conclusion:

So, Pseudomonas and Thiobacillus are responsible for denitrification

★ Additional Information

Rhizobium and Azotobacter are responsible for nitrification.

61. Answer: d

Explanation:

Concept:-

- Drugs interact with macromolecular targets and generate a biological response .
- If such biological responses are therapeutic and useful, the chemicals are called **medicines** and are further used in the diagnosis, prevention, and treatment of diseases.
- Some of the medicinal plants are wild, these plants are collected and sent to the centers of researches to work out their medicinal value.
- A good number of them are cultivated on a commercial basis.

Explanation:-

- Scientific name of belladonna is **Atropa Belladonna**.
- **Atropa Belladonna** belong to solanaceae family.
- **Belladonna drug** is obtained from the leaves of this plant.
- The plant is a perennial herb.
- **Belladonna** is used extremely to relieve pain.

Therefore “Belladonna” medicine is obtained from leaves and roots.

★ Additional Information

Some of the important drug yielding plants are-

Rauwolfia

- Rauwolfia belongs to the Apocynaceae family.
- The dried roots are an important source of alkaloids.
- It has a depressant action on the central nervous system.

Opium

- Opium belongs to the Papaveraceae family.
- The plant is an erect herb with having large globose capsule.
- Opium has narcotic and sedative effects.

62. Answer: b

Explanation:

Explanation:

- Jute is a natural fibre obtained from the bark of the white jute plant called *Corchorus capsularis*.

Scientific classification:

Kingdom: Plantae

Order: Malvales

Family: Malvaceae

Genus: Corchorus

Species: C. capsularis

Characters -

Plant type	Shrub
Height	Two meters or more
Origin	China
Grown in	India, Bangladesh

★ Important Points

- Another common jute variety is dark jute or Tossa obtained from Corchorus Olitorius.
- Berrya ammonilla - It is a deciduous tree that yields timber.

63. Answer: a

Explanation:

Concept-

- **Fibres** are thread-like **sclerenchymatous tissues** obtained from different parts of the plant body.
- They are usually long with **thick walls and pointed ends** .
- The thickening of the walls is either due to the deposition of **lignin or cellulose**.

Explanation -

- **Cotton** is obtained from **Gossypium** .
- **Cotton** is the most important commercial textile **fibre** .
- It is used for many purposes, especially of **clothing** .
- **Fibres** are produced by seed coats.

- They are also used for making ropes, threads, etc.

Therefore cotton is obtained from *Gossypium*.

★ Additional Information

Rauwolfia

- Rauwolfia belongs to the Apocynaceae family.
- The dried roots are an important source of alkaloids.
- It has a depressant action on the central nervous system.

Glycine max

- Soyabean scientific name is glycine max.
- The seeds of this plant are rich in protein.
- It has 30-60% protein content.

Oryza sativa

- Rice scientific name is Oryza sativa.
- The rice grains are used as food.

64. Answer: c

Explanation:

The correct answer is Epigynous.

Explanation:

- The **Compositae family** is known as **Asteraceae** .
- Compositae family possess a **capitulum or head type of inflorescence** in flowers.
- In the Compositae family, the **flower is Epigynous** because it possess the **inferior ovary** .
- The thalamus grows upwards to completely cover the ovary and also fused inseparably with the latter.

- The other floral parts arise at the top of the fused thalamus and ovary.
- The **ovary is called inferior ovary**.
- Example- *Helianthus* (sunflower), *Cucurbita* (pumpkin)

★ Additional Information

Hypogynous-

- In hypogynous, the **ovary is present at the top of the thalamus** .
- The stamen, petals, and sepals are separate and successively inserted below the ovary.
- In this family of flowers, **ovary is superior** , whereas the **rest of the structures are inferior** .
- Example- Brassica, Hibiscus

Perigynous-

- The margin of thalamus grows upwards forming a cup-like structure called a calyx tube.
- The calyx tube encloses the ovary but remains free from it and the sepals, petals, and stamens are in it.
- The **ovary is half inferior** .
- Example- Rose, Peach

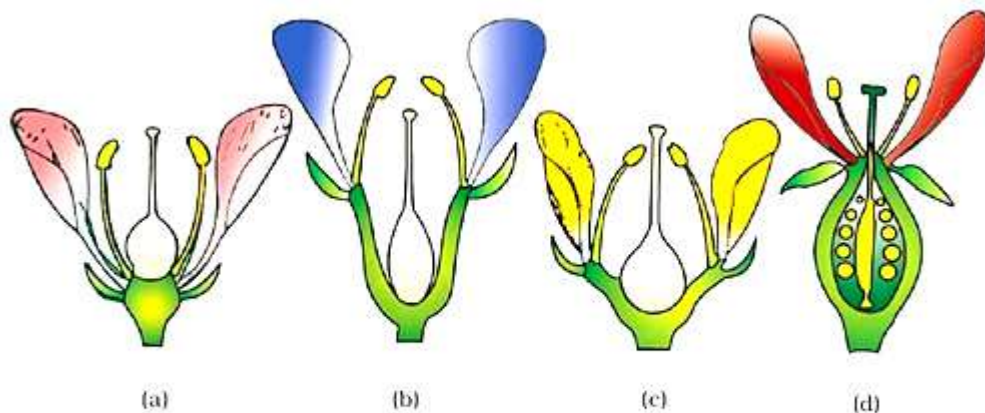

Position of floral parts on thalamus : (a) Hypogynous (b) and (c) Perigynous (d) Epigynous

65. Answer: d

Explanation:

Cocaine is obtained from the Erythroxyllum plant.

★ Key Points

- Coca alkaloid or **cocaine** is obtained from the coca plant Erythroxyllum coca, native to South America.
- It interferes with the transport of the **neuro-transmitter dopamine** .
- **Cocaine** , commonly called coke or crack is usually snorted.
- It has a potent stimulating action on the **central nervous system** , producing a sense of euphoria and increased energy.
- An excessive dosage of **cocaine** causes hallucinations.

★ Additional Information

Poppy plant

- Opioids are drugs, which bind to specific opioid receptors present in our central nervous system and gastrointestinal tract.
- Heroin, commonly called smack is chemically diacetylmorphine which is a white, odorless, bitter crystalline compound.
- This is obtained by acetylation of morphine, which is extracted from the latex of poppy plant Papaver somniferum.
- Generally taken by snorting and injection, heroin is a depressant and slows down body functions.

Cannabis plant

- Cannabinoids are a group of chemicals, which interact with cannabinoid receptors present principally in the brain.
- Natural cannabinoids are obtained from the inflorescences of the plant Cannabis sativa.
- The flower tops, leaves, and the resin of the cannabis plant are used in various combinations to produce marijuana, hashish, charas, and ganja.

- Generally taken by inhalation and oral ingestion, these are known for their effects on the cardiovascular system of the body.

Atropa plant

- Scientific name of belladonna is Atropa Belladonna.
- Atropa Belladonna belong to solanaceae family.
- Belladonna drug is obtained from the leaves of this plant.
- The plant is a perennial herb.
- Belladonna is used extremely to relieve pain.

66. Answer: c

Explanation:

Concept:

Bond Polarity

- In a covalent chemical bond, the more electronegative the element more is its tendency to attract the electron cloud towards itself.
- Thus one of the atoms (more electronegative one) attains a partial negative charge, and the other (less electronegative) attains a partial positive charge creating a dipole.
- The stronger the separation of charges, the stronger is the polarity of the bond.
- When the electronegativity difference is zero, the bond is nonpolar covalent.

Dipole moment

- Dipole moment arises in a polar bond be it ionic or covalent.
- The greater the separation of charges between the atoms in bonds, the greater is the value of dipole moment.
- Dipole moment is a vector quantity that means it has a direction as well as magnitude.
- The direction of the dipole moment in a bond is towards the more electronegative atom.

- The direction of the dipole in a molecule is the resultant of all the bond dipole moments.
- It has to be noted that the bonds in a molecule can be polar but the molecule can have the net dipole moment as zero. The difference between them is listed below.

Bond polarity	Molecular polarity
Bond polarity is a concept that produces polarity in covalent bonds .	Molecular polarity is a phenomenon that produces polarity in covalent compounds .
Depends on the difference of E.N values of the bonded atoms.	Depends on the geometry of the molecules and types of atoms present.

Explanation:

BF₃:

- The geometry of the molecule is **trigonal planar**. The three fluorine atoms occupy three corners of a triangle.
- **Fluorine** is **more** electronegative than **Boron** and thus bond moment acts from **B to F**.
- The resultant bond moments **cancel out each other** as shown below:

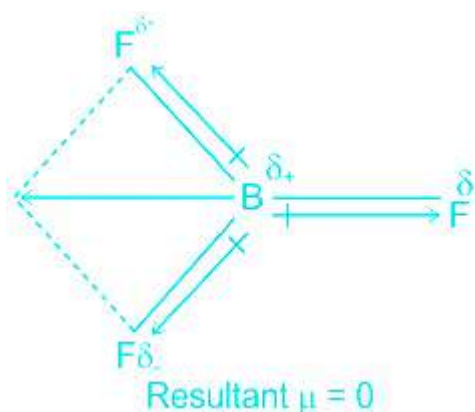

- The net dipole moment becomes zero as the moment acting forwards is canceled by the moment acting backward.

So, BF_3 molecule has zero dipole moment.

★ Additional Information

NH_3 :

- The shape of the ammonia is **distorted tetrahedral**.
- Nitrogen is more **electronegative** than H so, the bond moment acts **towards Nitrogen**.
- There is also a **lone pair** of electrons in the molecule and as lone pairs are more polar, the dipole acts towards it.
- Resultant dipole acts **upwards**.

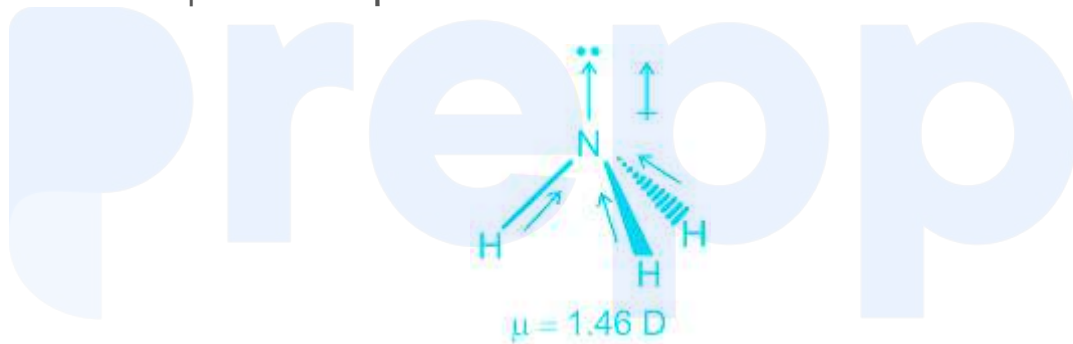

H_2O : **Your Personal Exams Guide**

- **Oxygen** is the central molecule.
- As **oxygen** is **more** electronegative, the **O-H** bond moment acts towards it.
- However, there are **two lone pair** of **electrons** in the molecule, and as they are **more electronegative**, the **net dipole** moment acts **upwards**.

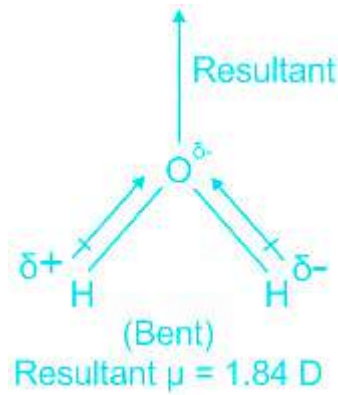

67. Answer: b

Explanation:

Concept:

- The metallic property of the elements of the periodic table decreases when we move across the group whereas it increases when we go down the group, as we go down the number of electrons increases, and thereby their distance from the nucleus increases.
- This increase causes them to shed more electrons and thereby have a greater electropositive or metallic character.

Your Personal Exams Guide

Table: Modern Periodic table

The zig zag-line separates the metals from the non metals

Legend:

- Alkali metals
- Alkaline Earth Metals
- Halogens
- Nobel gases

GROUP NUMBER	1	2	Transition Metals										GROUP NUMBER						18
	1	2	3	4	5	6	7	8	9	10	11	12	13	14	15	16	17	18	
1	H																		He
2	Li	Be											B	C	N	O	F	Ne	
3	Na	Mg											Al	Si	P	S	Cl	Ar	
4	K	Ca	Sc	Ti	V	Cr	Mn	Fe	Co	Ni	Cu	Zn	Ga	Ge	As	Se	Br	Kr	
5	Rb	Sr	Y	Zr	Nb	Mo	Tc	Ru	Rh	Pd	Ag	Cd	In	Sn	Sb	Te	I	Xe	
6	Cs	Ba	La*	Hf	Ta	E	Re	Os	Ir	Pt	Au	Hg	Tl	Pb	Bi	Po	At	Rn	
7	Fr	Ra	Ac**	Rf	Db	Sg	Bh	Hs	Mt	Ds	Rg	Cn	Uut	Ff	Mcc	Lv	Ts	Og	

*Lanthanoides 6	58	59	60	61	62	63	64	65	66	67	68	69	70	71
	Ce	Pr	Nd	Pm	Sm	Eu	Gd	Tb	Dy	Ho	Er	Tm	Yb	Lu
**Actinoides 7	90	91	92	93	94	95	96	97	98	99	100	101	102	103
	Th	Pa	U	Np	Pu	Am	Cm	Bk	Cf	Es	Fm	Md	No	Lr

Explanation:

- In the above periodic table, in the 3rd group, the metallic character will be

$P < Si < Mg < Na$

- Also, we know metallic characters increase down the group.
- So, Mg has more metallic character than Be.

Therefore, the correct sequence is

$P < Si < Be < Mg < Na$

68. Answer: a

Explanation:

Concept:

Photochemical Smog

- Photochemical smog is formed when ultraviolet light from the sun reacts with nitrogen oxides in the atmosphere.
- Photochemical smog is a brownish-gray haze caused by the action of solar ultraviolet radiation on the atmosphere polluted with hydrocarbons and oxides of nitrogen.
- It contains anthropogenic air pollutants, mainly ozone, nitric acid, and organic compounds, which are trapped near the ground by temperature inversion. These pollutants and also some others can affect human health and cause damage to plants.
- Photochemical smog often has an unpleasant odor due to some of its gaseous components.
- Photochemical smog is also known as "Los Angeles smog."
- **Nitric oxide (NO) and nitrogen dioxide (NO₂) are emitted from the combustion of fossil fuels, along with being naturally emitted from things such as volcanos and forest fires. These are main constituent of the photochemical smog.**
- When exposed to ultraviolet radiation, NO₂ goes through a complex series of reactions with hydrocarbons to produce the components of photochemical smog—a mixture of ozone, nitric acid, aldehydes, Peroxyacyl nitrates (PANs) and other secondary pollutants.

Conclusion:

So the main constituent is NO₂ gas.

69. Answer: a

Explanation:

- Methaemoglobinaemia or Blue baby syndrome or is commonly caused due to the presence of nitrate in drinking water.
- In this syndrome, the ability of blood to carry vital oxygen around the body decreased.
- According to the World Health Organisation, nitrate levels in drinking water sources should be below around 50mg/litre.

70. Answer: b

Explanation:

Ionization Enthalpy: Ionization enthalpy is the energy required to remove loosely bonded electron from valance shell of gaseous atom

★ Key Points

Factors affecting ionization energy

1. Atomic radius: The greater the distance between the nucleus and the outer electron, the less the ionization energy.
2. Nuclear Charge: The larger the nuclear charge, the greater will be the ionization energy.
3. Shielding effect: Greater the shielding effect, lesser the ionization energy.
4. Electronic Configuration : Full or half-full sub-level requires additional energy to be remove

Explanation:

Periodic trends in ionization enthalpy of elements

Your Personal Exams Guide

ELECTROPOSITIVE NATURE OF METALS

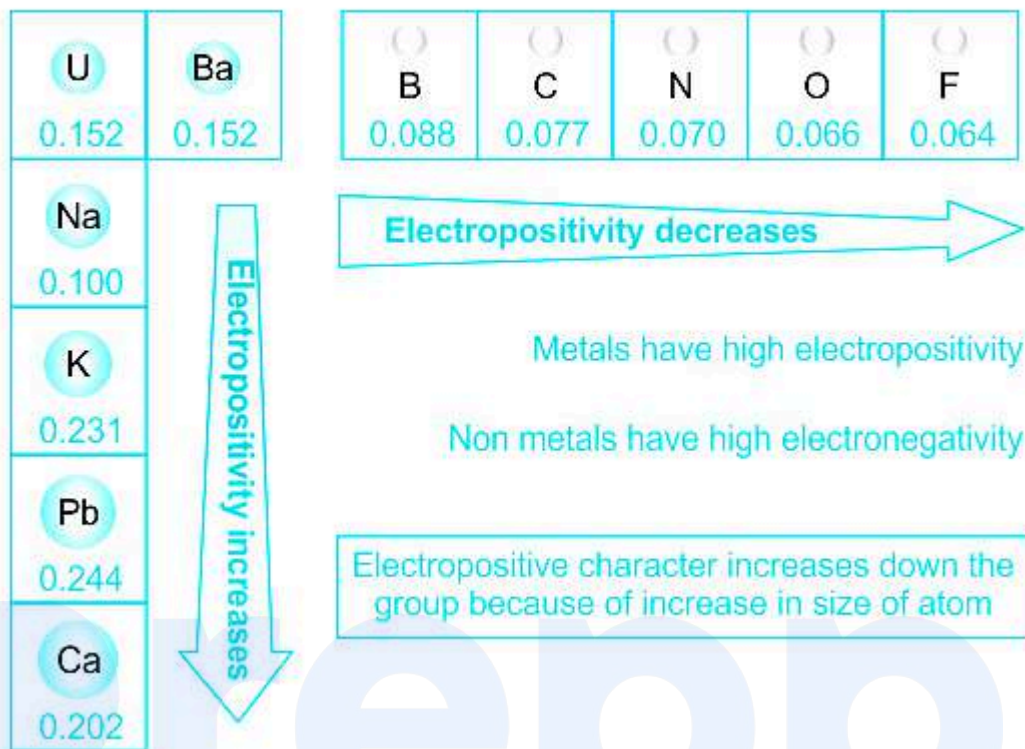

Thus it is conclude that $C^{2+} \rightarrow C^{3+} + 1e^{-}$ will need maximum amount of energy.

★ Hint

- Due to nuclear Charge and right side position of carbon atom will need maximum amount of energy to loose electron.
- Due to shielding effect Calcium and potassium will need lesser amount of energy to loose electron.

71. Answer: c

Explanation:

Explanation:

- Concave mirrors have **reflecting curved inward**.
- They give a parallel beam of light when light rays are present at the focus of the mirror.

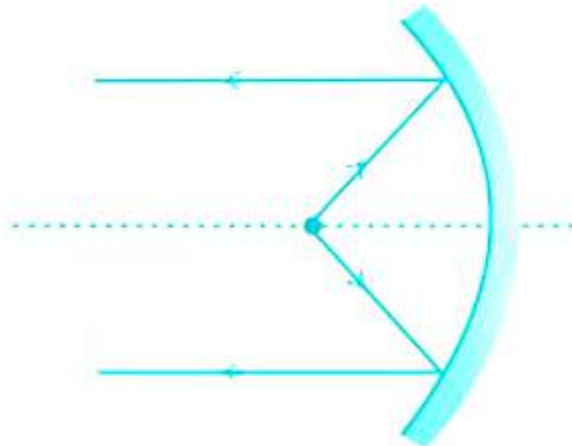

- So in headlights, the source of light or the light bulb is present at the focus of the mirror.
- This gives a parallel beam of light on the road.
- So the headlight used in vehicles uses a concave mirror.

★ **Additional Information**

- Uses of Concave mirrors: Headlight, dentist mirror, shaving mirror.
- Uses of Convex mirror: Camera, rear view mirror
- Concave and convex mirror are part of spherical mirrors.
- Concave have reflecting surface curved inward while convex have reflecting surface curved outward.

72. **Answer: c**

Explanation:

Concept:

Resistivity

- The property of a conductor that opposes the flow of electric current through them and is independent of the shape and size of the materials but depends

on the nature and temperature of the materials is called resistivity.

- The unit for resistivity is the ohm-meter ($\Omega\text{-m}$).
- The resistivity of a material depends on its nature and the temperature of the conductor and doesn't depend on its shape and size (length and area).
- Resistance : The property of any conductor that opposes the flow of electric current through it and depends on the shape and size of the materials, temperature, and nature of the materials is called resistance.
 - It is denoted by R and the SI unit is the ohm (Ω).
- The resistance is given by:

$$\Rightarrow R = \frac{\rho l}{A}$$

ρ is resistivity, l is length, A is cross-sectional Area

- The resistivity of a conductor increases with temperature.

Temperature coefficient of resistance (α) :

- The change in electrical resistance of a substance with respect to a per degree change in temperature .
- α depends on the type of material.

Variation of resistance with temperature:

Let ρ_0 and ρ_T represent the resistivity at a temperature of T_0 and T respectively.
Therefore

$$\Rightarrow \rho_T = \rho_0 [1 + \alpha (T - T_0)]$$

Resistivity of semiconductors

- Compared to insulators , the energy band gap is very less in semiconductors. Thus, the electrons require very little energy to jump to the conduction band.
- When the temperature is increased, most of the electrons acquire a sufficient amount of energy and jumps to the conduction band.
- Hence, the conduction increases i.e. conductivity increases.

- We know that conductivity is the reciprocal of resistivity. Thus, on increasing the temperature of a semiconductor, resistivity decreases.
- Semiconductors have a negative temperature coefficient. So, α is negative.

Explanation:

Among the given options Silicon is semiconductors and the rest options are metals and hence conductors.

So, the resistivity of silicon will decrease with an increase in temperature.

★ **Additional Information**

- Energy Band: The different energy levels with continuous energy variation of electrons in a material are called energy bands.
- Valance Band: The energy band which includes the energy levels of the valence electrons is called the valence band.
- Conduction Band: The energy bands above the valence bands are called the conduction bands.
- The conduction band holds those electrons that are responsible for conduction.

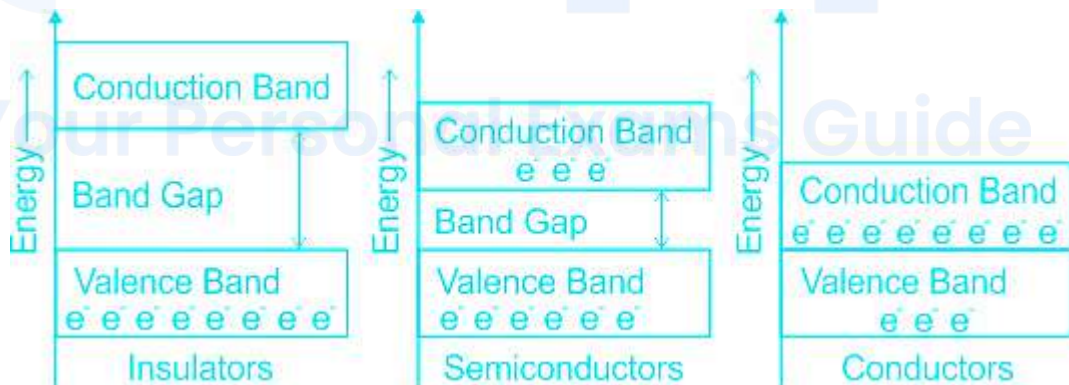

73. Answer: a

Explanation:

Concept:

- **Acceleration** : The rate of change of velocity is called acceleration.
- **Acceleration due to gravity (g)**: The acceleration by which an object falls on the surface of the earth is called acceleration due to gravity.

The value of g is given as

$$g = \frac{GM}{r^2}$$

G is the Universal Gravitational Constant, r is the radius of the planet, M is the mass of the planet (All are constant).

The value of g on surface of earth is around 9.8 ms^{-2} .

Explanation:

- The value of the acceleration due to gravity is not changing with time is constant.
- It is not changing with time.
- So the graph will be a straight line parallel to the time axis.
- Therefore the correct option is



74. Answer: a

Explanation:

Concept:

1024 bytes are there in a kilobyte.

- The smallest unit of measurement used for measuring data is a bit.
- A single bit can have a value of either zero(0) or one(1).

- It may contain a binary value (such as True/False or On/Off or 1/0) and nothing more.
- Therefore, a byte, or eight bits, is used as the fundamental unit of measurement for data storage.
- Computer storage and memory are often measured in megabytes (MB) and gigabytes (GB).
- A medium-sized novel contains about 1 MB of information.

★ Additional Information

Byte

- A bit is a basic unit of information in information theory, computing, and digital communications.
- The name is a portmanteau of binary digits.

calculate kb. to bit

- 1 Kilobyte is equal to 8000 Bit (eight thousand bit)
- 1 Bit is equal to 0.000125 Kilobyte (zero point zero × 3 one hundred and twenty-five kb)
- 1 Kilobyte is equal to 8000 bits (eight thousand bits)
- 1 Bit is equal to 1 bits (one bits)
- 1 Kilobyte is equal to 8000 Bit (eight thousand bit).

75. **Answer: d**

Explanation:

Concept:

Electromagnetic waves (EM Waves)

- The electromagnetic wave is a special kind of wave which do not require any material medium for its propagation.
- The EM wave is a combination of the time-varying oscillating electric and magnetic field which propagates in a space with a speed very

closed to the speed of light.

- It is also called the EM wave.
- EM waves are formed when the electric and magnetic field comes in contact and oscillates perpendicular to each other.
- The direction of propagation of EM is perpendicular to that of the oscillating electric and magnetic field.

Explanation:

- The electromagnetic waves are categorised into different waves based on the frequency of the wave.
- The following diagrams represents different types of electromagnetic waves.

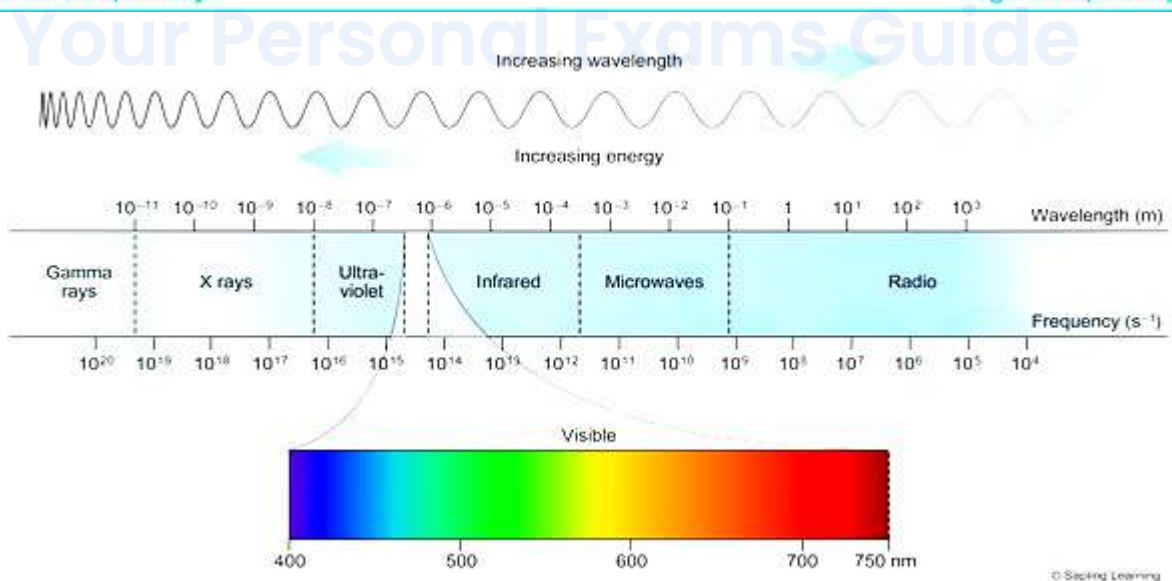
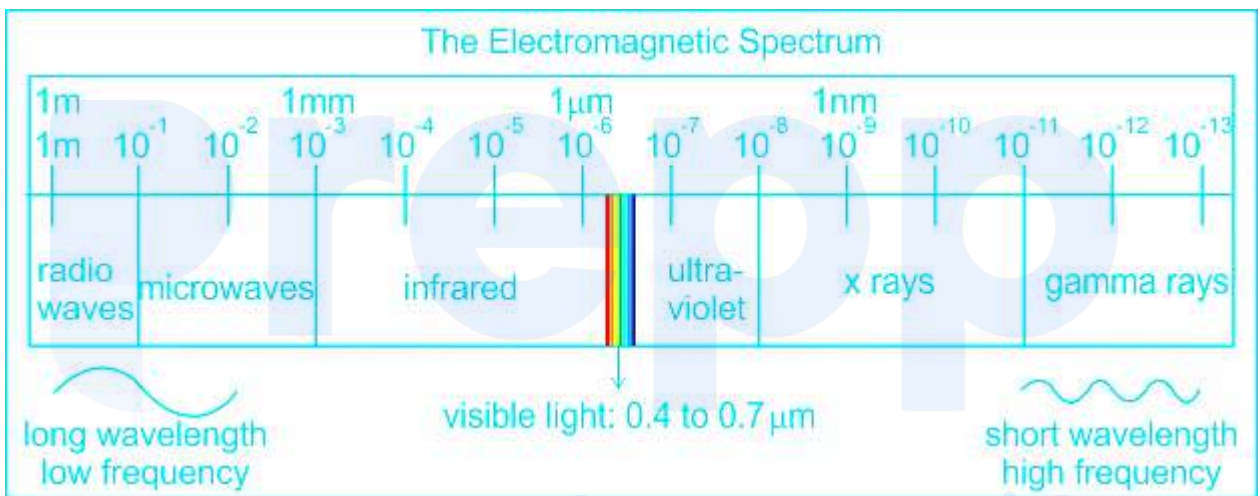

- The frequency is increasing while moving left to right on the above spectrum.

- From the diagram, we can see that the X rays have highest frequency. (10^{17} to 10^{19}) Hertz.

76. Answer: b

Explanation:

Concept:

- Distance travelled is the product of speed and the time taken while travelling with that speed.

$$speed = \frac{distance}{time}$$

- The average speed is defined as the total distance travelled by the total time taken during the process.

$$Average\ speed = \frac{total\ distance}{total\ time}$$

Calculation:

Let the distance from X to Y is d

So, the distance travelled from X to Y or Y to X is d.

Total distance hence travelled is $d + d = 2d$

Speed of Car moving from X to Y is V_1

distance from moving X to Y is d

time taken

$$t_1 = \frac{d}{v_1} \quad \text{-----(1)}$$

Similarly, time taken from moving Y to X is

$$t_2 = \frac{d}{v_2} \quad \text{-----(2)}$$

total time taken t

$$t = t_1 + t_2 = \frac{d}{v_1} + \frac{d}{v_2}$$

Average speed is the total distance by the total time

$$s = \frac{2d}{\frac{d}{v_1} + \frac{d}{v_2}}$$

$$\implies s = \frac{2d}{d \left(\frac{1}{v_1} + \frac{1}{v_2} \right)}$$

$$\implies s = \frac{2V_1V_2}{V_1+V_2}$$

Clearly, the average speed is the harmonic mean.

★ Additional Information

If H is the Harmonic mean of numbers a and b and is given by

$$H = \frac{2ab}{a+b}$$

Arithmetic mean = Sum of terms/Number of terms

Geometric mean = G.M. = \sqrt{ab}

77. Answer: d

Your Personal Exams Guide

Explanation:

Concept:

- Temperature: It is the measure of the degree of hotness and coldness of a body.
 - The SI unit of temperature is Kelvin (K).

Fahrenheit and Celsius are measurements of temperature and are related to each other as follows:

$$C = (F - 32) \times \frac{5}{9}$$

Where C is the temperature in Celsius and F is the temperature in Fahrenheit.

Explanation:

Since we need temperature in Fahrenheit and Celsius to be equal :

Now, let $C = F = x$

So,

$$x = (x - 32) \times \frac{5}{9}$$

$$\text{or, } 9x = 5x - 160$$

$$\text{or, } 4x = -160$$

$$\text{or, } x = -40$$

Therefore, $^{\circ}\text{C} = ^{\circ}\text{F} = -40^{\circ}$

★ Additional Information

Kelvin is the SI unit of temperature. $K = C + 273$

78. **Answer: d**

Explanation:

The correct option is Freon.

★ Key Points

- Freons are chlorofluorocarbons compounds of methane and ethane.
- Freon 12 - dichlorodifluoromethane (CCl_2F_2) is commonly known as freon.
- It is a colorless gas.
- It is usually used as a refrigerant, aerosol propellant.
- It can cause ozone depletion.

★ Additional Information

- The properties of Phosphine gas (PH_3) are - It is a colorless gas, smelling like rotten fish, and is a highly poisonous gas.
 - It explodes in the presence of traces of oxidizing agents like HNO_3 , Cl_2 , and Br_2 . It is slightly soluble in water.
-

79. Answer: a

Explanation:

Concept:

- Electric current is the rate of flow electric charge or free Electrons in a definite direction through any section of wire. Its SI unit is ampere(A).
- The direction of the conventional current corresponds to the direction of positive charge which is from higher potential(positive) to lower potential(negative).

$$I = Q / t$$

I is current, Q is charge, t is time

Explanation:

$$Q = I t$$

So Charge is the product of current and time.

Unit of current is Ampere, and unit of time is an hour.

So, Amount of charge or Quantity of electricity is Ampere-hour

80. Answer: c

Explanation:

Concept:

- Magnetic field due to a straight current-carrying conductor: Biot-Savart Law
 - Magnetic field B at a radial distance r , due to a wire carrying current is given by:

$$B = \frac{\mu_0 I}{2\pi r}$$

Where μ_0 is the permeability of free space ($4\pi \times 10^{-7} \text{ Tm/A}$), and I is the current intensity.

Explanation:

- So a current-carrying wire has a magnetic field around it.
- Electromagnets are based on this principle.
- The wire does not have an electric field around it.
- A single charge stationary has an electric field around it.
- But, when the charge is moving in a conductor, the net electric charge across the wire will be zero, as the number of electrons entering the conductor is equal to charges exit from the conductor.
- Also according to the gauss law, if the charge enclosed is zero, the net field will be zero.

So there is only a magnetic field.

81. Answer: a

Explanation:

The correct answer is Nereis, Earthworm, Hirudinaria.

Explanation-

- Classification of living beings helps in easy identification.
- In spite of differences in structure and form of different animals, there are certain fundamental features common in various individuals in relation to the arrangement of cells, body symmetry, nature of coelom, patterns of digestive, circulatory, or reproductive systems.

- The phylum Annelida includes segmented worms, such as sandworms, earthworms, and leeches .
- Nereis, Earthworm, Hirudinaria all belong to the **phylum Annelida** .
- The phylum Annelida is divided into three classes: **Polychaeta** ,**Oligochaeta**, and **Hirudinea** .
- **Class 1. Polychaeta** -
 - Body bears a distinct head with sense organs (eyes, tentacles).
 - Setae are long, numerous.
 - Sexes are separate gonads are temporary.
 - Fertilization is generally external.
 - **Example:***Nereis* - the sandworm
- **Class 2. Oligochaeta-**
 - Body lacks head and parapodia.
 - Setae are small and fewer.
 - Sexes are united.
 - Fertilization occurs in the ootheca.
 - **Example:***Pherentia* - the earthworm
- **Class 3. Hirudinea** -
 - Body lacks head and parapodia.
 - Setae are also absent.
 - Sexes are united.
 - Fertilization takes place in the ootheca.
 - **Example:***Hirudinaria* - the cattle leech



Nereis

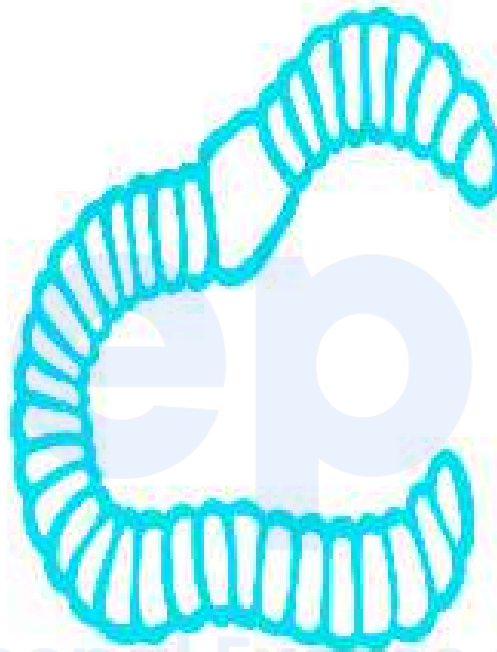

Earthworm

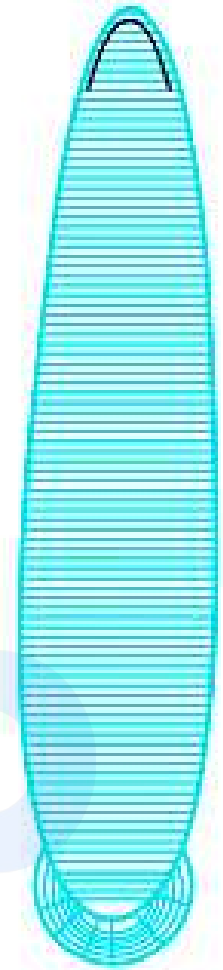

Hirudinaria

prepp
Your Personal Exams Guide

Thus, *Nereis*, *Earthworm*, and *Hirudinaria* belong to the *Annelida* Phylum.

82. Answer: a

Explanation:

The correct answer is unicellular animal.

Explanation:

- An amoeba often known as **amoeboid** is a **microscopic unicellular animal** found in pond water.
- Amoeba has a cell membrane, a rounded, dense nucleus, and many small bubble-like vacuoles in its cytoplasm.
- Amoeba constantly changes its shape and position.
- It pushes out one, or more finger-like projections, called **pseudopodia** or false feet for movement and capture of food.
- Amoeba **feeds on some microscopic organisms** .
- When it senses food, it pushes out pseudopodia around the food particle and engulfs it.

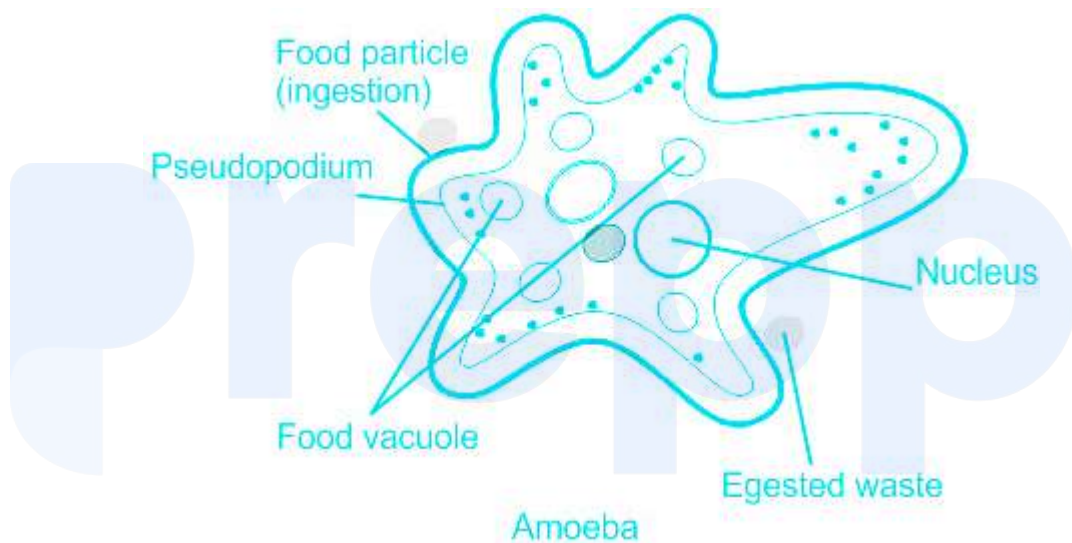

★ Additional Information

Unicellular protist-

- Most protists are **unicellular** , which means that the organism is **made up of a single cell**.
- Protists aren't actual plants, animals, or fungi.
- These are mostly **aquatic organisms**.
- Some protists also live in the bodies of animals as parasites.
- Examples- Dinoflagellates; Giardia

Unicellular plant-

- A unicellular plant are **autotrophs** and **contain chlorophyll**.

- They include both **multicellular and unicellular species**.
- They are found in freshwater.
- Examples- Chlamydomonas, Chlorella

Bacterium-

- These are **single-celled microbes**.
- They are found in all kinds of habitats.
- They are **prokaryotic microorganisms**.
- In bacteria organised nucleus is absent.
- Bacteria show both autotrophic and heterotrophic mode of nutrition.
- Example- Escherichia coli

83. Answer: a

Explanation:

The correct answer is Porifera.

Explanation:

Porifera-

- Members of this phylum are commonly known as **sponges** .
- They are generally marine and mostly asymmetrical animals.
- Sponges have a **water transport or canal system** .
- There are holes or '**pores**' , all over the body.
- These lead to a **canal system** that **helps in circulating water** throughout the body **to bring in food and oxygen** .
- Water enters through minute pores (ostia) in the body wall into a central cavity, spongocoel, from where it goes out through the osculum.
- The canal system of the Porifera phylum is helpful in **food gathering, respiratory exchange** and **removal of waste** .
- These animals are covered with a hard outside layer or skeleton.
- **Examples:** *Sycon* (Scypha), *Spongilla* (Fresh water sponge).

Thus, *the presence of the 'Canal System' is the characteristic feature of phylum Porifera.*

★ Additional Information

Echinodermata-

- They are generally marine, solitary, and triploblastic.
- Animals are radially symmetrical and larva are bilaterally symmetrical.
- The most distinctive feature of echinoderms is the presence of **water vascular system** which helps in the locomotion, capture, and transport of food and respiration.
- **Examples:** *Asterias* (Starfish), *Echinus* (Sea urchin)

Coelenterata-

- They are aquatic, mostly marine, free swimming.
- Animals are radially symmetrical.
- A **coelenteron** or **gastrovascular cavity is present**, which is blind at one end and opens as mouth or **hypostome** at other end.
- Digestion is extracellular and intracellular.
- **Examples:** *Adamsia* (Sea anemone), *Pennatula* (Sea-pen)

Platyhelminthes-

- The phylum Platyhelminthes includes flatworms.
- They are the most primitive bilateral animals.
- In phylum Platyhelminthes **flames cells are present** for excretion and osmoregulation.
- **Examples :** *Taenia* (Tapeworm), *Fasciola* (Liver fluke)

84. Answer: d

Explanation:

The correct answer is Aves.

★ Key Points

Aves -

- The class Aves includes **birds** or **flying vertebrates** .
- A characteristic feature of Aves is the **presence of feathers** .
- The birds are unique in having a coat of feathers and in resting on the hindlimbs alone.
- Respiration takes place only by the **lungs** .
- **Lungs are respiratory organs** , which are spongy, inelastic, and are connected to **large air sacs** .
- Endoskeleton is **bony** , but delicate and light.
- Bones are **pneumatic** i.e., **contain air cavities** to reduce weight.
- These are warm -blooded animals.
- **Example** - *Covus* (Crow), *Neophron* (Vulture)

★ Additional Information

Amphibia-

- Amphibians can live in aquatic as well as terrestrial habitats.
- Most of them have two pairs of limbs.
- **Respiration** takes place **by gills, lungs** and through **skin** , either separately or in combination.
- The endoskeleton is **largely bony** .
- **Example** - *Hyla* (Tree frog), *Bufo* (Toad)

Mammalia-

- The most unique mammalian characteristic is the presence of **milk producing glands** (mammary glands) by which the young ones are nourished.
- **Respiration** occurs only **by lungs** . The lungs are spongy and elastic.
- The endoskeleton is **bony** .
- **Example** - *Ornithorhynchus* (Platytus), *Camelus* (Camel)

Reptilia-

- The reptiles were the **first vertebrates** fully adapted for life on dry land.
 - Some live in water but they too return to land for breeding.
 - **Respiration** occurs by **lungs** . Gills are not developed at any stage.
 - The endoskeleton is **bony** .
 - **Example** - *Chelone* (Turtle), *Crocodilus* (Crocodile)
-

85. Answer: d

Explanation:

★ Key Points

- **Gandhi Bug:** It is a pest of rice that attacks rice in the season of ripening.
- **Culex** is a genus of mosquitoes that are responsible for several diseases.
- **Aphid:** Aphids are soft-bodied insects. They use their piercing-sucking mouthparts to feed on plant sap.
- **Apis** is the genus of bees. It is beneficial as they provide honey.

★ Additional Information

Kingdom Classification hierarchy: Kingdom, phylum, class, order, family, genus, and species, whereas Species is the lowest level in the hierarchy.

86. Answer: b

Explanation:

★ Key Points

- Sericulture is related to the rearing of silkworms.
- Sericulture is an agro-based industry.
- It involves the rearing of silkworms for the production of raw silk.
- India is the second-largest producer of silk within the globe.

★ Additional Information

Culture	Related
Apiculture	Bee farming
Floriculture	Flower farming
Horticulture	Vegetable farming
Pisciculture	Fish farming
Vermiculture	Earthworm farming
Viticulture	Grapes farming
Aquaculture	fish, shellfish, and other aquatic animals
Fungi culture	Mushroom farming

87. Answer: a

Explanation:

The correct answer is Medulla of the brain.

Explanation-

- The respiratory center of the body is present in the *Medulla of the brain*.
- Respiration is regulated by a specialized center present in the medulla region of the brain called the **respiratory rhythm center**.
- The respiratory rhythm center is primarily **responsible for the regulation of respiration**.
- Another center present in the pons region of the brain called **pneumotaxic center** can moderate the functions of the Respiratory rhythm center.
- Neural signal from this center can reduce the duration of inspiration and thereby, alter the respiratory rate.
- The medulla contains centers that **control respiration, cardiovascular reflexes, and gastric secretions**.

★ Additional Information

Spinal cord-

- The spinal cord is **made up of nerves** that **supply information** . It involves more complex mechanisms and neural connections.
- These are concentrated in the brain, which is the main coordinating center of the body.
- The brain and spinal cord constitute the **central nervous system** .
- They **receive information** from all parts of the body and integrate it.

Cerebellum of the brain-

- It is the **part of the Hindbrain** .
- It has a very convoluted surface in order to provide the additional space for many more neurons.

Cerebral hemisphere of the brain-

- It is the **part of the forebrain** .
- A deep cleft divides the cerebrum longitudinally into two halves, which are termed as the left and right cerebral hemispheres.
- The hemisphere is connected by a tract of nerve fibers called **corpus callosum**

Your Personal Exams Guide

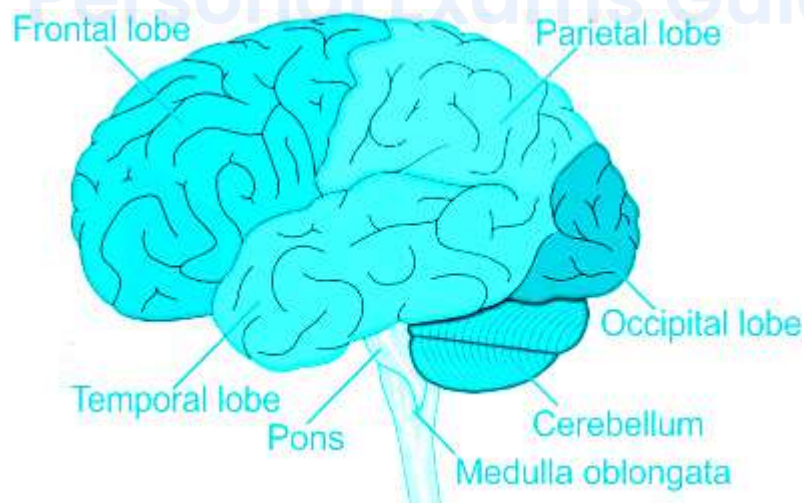

88. Answer: c

Explanation:

Explanation:

- Loop of Henle is part of Nephron.
- It is a functional and structural unit of the kidney which plays major role in Excretion.
- Loop of Henle, long U-shaped portion of the tubule that conducts urine within each nephron of the kidney of reptiles, birds, and mammals .
- The principal function of the Loop of Henle is in the recovery of water and sodium chloride from urine .

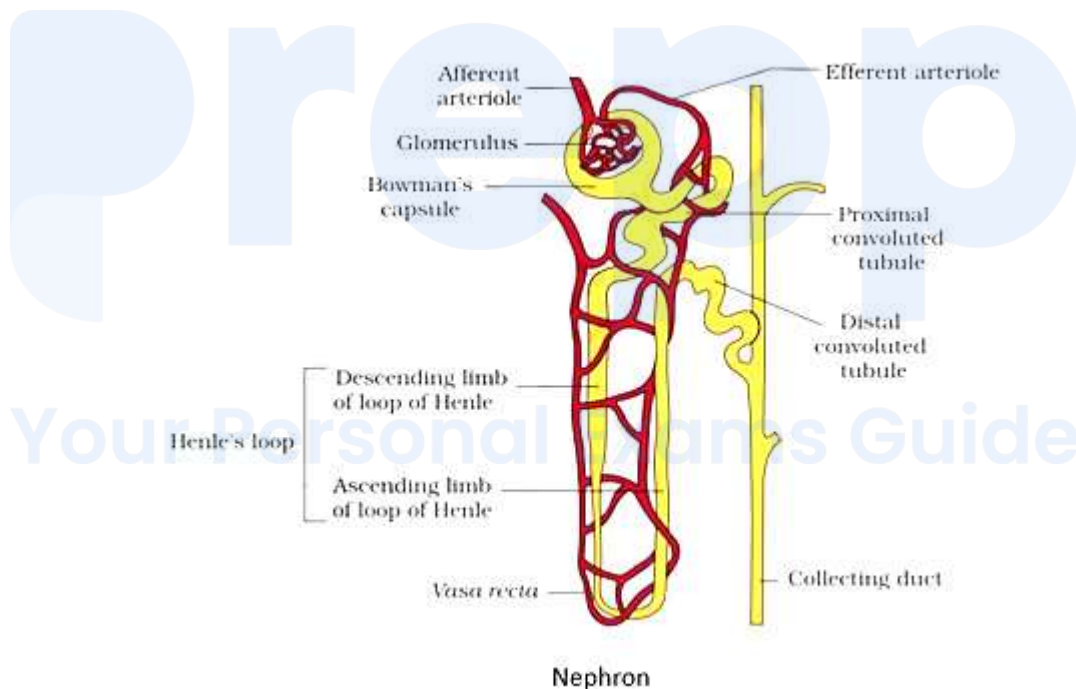

So the correct option is Excretion.

89. Answer: c

Explanation:

Spleen is an organ on the left side of the abdomen below the stomach.

★ Key Points

It performs two major functions:

1. Storage of blood - Blood vessels of spleen can alter their thickness and become wider or narrower depending on the situation. In case of emergency situations like trauma & severe injuries where a lot of blood gets lost, the spleen expands its vessels and holds the blood. This reserve blood is then transported to the organ where blood is required. For this reason, the spleen is also called the blood bank of the human body.
2. Filtration of blood - Spleen filters the blood & removes the old & dead RBCs. It acts like a maze from which healthy RBCs can easily pass while the old & dead RBCs get stuck in it. These are then broken down in the spleen by macrophages. For this reason, the spleen is also called as The Graveyard of RBCs.

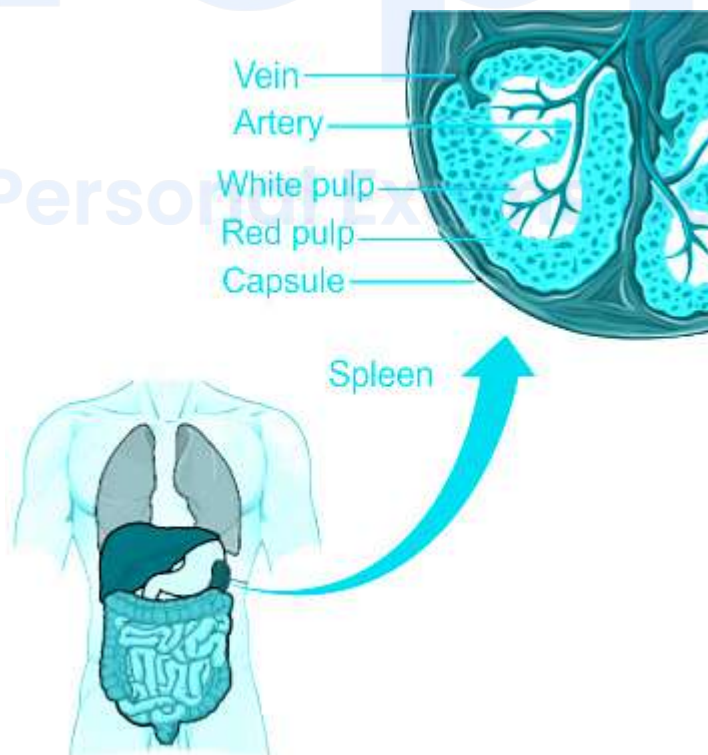

★ Additional Information

Heart:

- The heart is a mesodermally derived organ, that is present in the thoracic cavity, in between the two lungs, slightly tilted to the left. It has the size of a clenched fist. It is protected by a double-walled membranous bag, pericardium, enclosing the pericardial fluid.

Liver:

- The liver is the largest gland of the human body. It performs the function of detoxification of harmful substances in the body
- For example, it converts harmful ammonia into urea, It also breaks down alcohol and other such substances in the blood.

Bone marrow :

- Bone marrow refers to the tissue located in the hollow interior of long bones. It is composed of adipose tissue, areolar tissue, and blood cells.
- Bone marrow is mainly of two types – red and yellow

90. Answer: c

Explanation:

The correct answer is Coelenterata.

Explanation:

Coelenterata-

- They are **aquatic, mostly marine, free-swimming** .
- Animals are **radially symmetrical** .
- Cnidarians exhibit two basic body forms called **polyp** and **medusa** .
- **Polyp is sessile, cylindrical structure with a mouth and tentacles facing upwards** , e.g., Hydra, Adamsia, etc.
- **Medusa is a free-swimming zooid with mouth and tentacles facing downwards** , e.g., Aurelia (jellyfish)

- Medusae may form polyps after sexual reproduction while polyps form medusae through vegetative budding.
- This phenomenon is called **polymorphism** , which helps in the division of labour.
- A coelenteron or gastrovascular cavity is present, which is blind at one end and opens as mouth or hypostome at other end.
- Digestion is **extracellular** and **intracellular** .

★ Additional Information

Porifera-

- Members of this phylum are commonly known as **sponges** .
- They are generally marine and mostly asymmetrical animals.
- Sponges have a **water transport** or **canal system** .
- The canal system of the Porifera phylum is helpful in food gathering, respiratory exchange, and removal of waste.
- These animals are covered with a hard outside layer or skeleton.
- Examples: *Sycon* (Scypha), *Spongilla* (Freshwater sponge).

Arthropoda-

- Arthropoda includes the **first and simplest segmented animals** .
- These are commonly called **jointed-legged animals** .
- They may be aquatic or terrestrial.
- Body is segmented externally. It has a distinct head, thorax, and abdomen.
- They have joined, paired appendages, which are present in some or all somites or segments. these perform various functions like walking, clinging, jumping, feeding, etc.
- Examples: *Apis* (Honey bee), *Bombyx* (Silkworm)

Annelida-

- The phylum Annelida includes **segmented worms** , such as sandworms, earthworms, and leeches.
- They may be aquatic, terrestrial and free-living or parasitic.

Explanation:

The electronegativity of different elements is given as

Atom (Period II)	Li	Be	B	C	N	O	F
Electromagativity	1.0	1.5	2.0	2.5	3.0	3.5	4.0
Atom (Period III)	Na	Mg	Al	Si	P	S	Cl
Electromagativity	0.9	1.2	1.5	1.8	2.1	2.5	3.0

Electronegativity decreases down the group and increases from left to right in a period.

So oxygen has the highest electronegativity in period II and sulphur in period 3.

The correct order of electronegativity hence is

$P < S < N < O$

92. Answer: b

Explanation:

Concept:

Knocking: The abnormal combustion of fuel in an engine is known as Knocking.

- Knocking is harmful for engine life. **To decrease the knocking tendency**, the extra chemicals are added to the petrol like Tetra Ethyl Lead, Tetra Methyl Lead ,etc
- By adding this chemicals, the anti-knocking property of petrol increases and **engine runs smoothly**. But due to presence of Lead in this chemicals, when fuel combust, the Lead particles gets separated.

- These Lead particles are is cause of air-pollution.
- These Lead particles are harmful for human as well as plants.

So, Tetra Ethyl Lead (TEL) is added to gasoline so that the gases coming out of vehicles may not Cause air-pollution is **incorrect Statement**.

★ Additional Information

Acid Rain:

- Normal rain has a pH of about 5.6 ; it is slightly acidic because carbon dioxide (CO₂) dissolves into it forming weak carbonic acid.
- Acid rain usually has a pH between 4.2 and 4.4.
- Acid rain results when sulfur dioxide (SO₂) and nitrogen oxides (NO_x) are emitted into the atmosphere and transported by wind and air currents.
- The SO₂ and NO_x react with water, oxygen, and other chemicals to form sulfuric and nitric acids.

OZONE LAYER:

- The ozone layer is an area or a continuous region in the stratosphere of the earth that includes high concentrations of ozone (O₃) and protects the earth from the sun's harmful ultraviolet (UV) radiation.

Insecticides:

- The use of insecticides in crops is meant to protect plants against harmful insects and increases crop yields.
- But the incessant use of insecticides has caused soil pollution.

93. Answer: b

Explanation:

Explanation:

- XeF₆ is a compound where Xe is the central element.

- Xe is a noble gas yet it reacts and does not follow the octet rule.
- As Xe is the largest of the noble gases, the electrons in the outer orbitals are loosely bound. Also, the energy difference between its valence shell 5p and higher energy orbitals 4f and 6s is low, so the paired electrons can easily jump to the higher energy orbitals, unpairing.
- The unpaired electrons then lead to covalent bonding between atoms such as F and O forming compounds like XeF₆, XeO₄.
- XeF₆ has a distorted octahedral structure with hybridization sp³d³.
- XeF₆ has seven electron pairs forming 6 bond pairs and one lone pair.

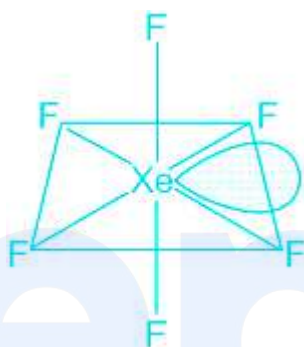

94. Answer: a

Explanation:

Concept:

Table: Modern Periodic table

The zig zag-line separates the metals from the non metals

Legend:
■ Alkali metals
■ Alkaline Earth Metals
■ Halogens
■ Nobel gases

PERIODS	GROUP NUMBER		Transition Metals										GROUP NUMBER						18	
	1	2	3	4	5	6	7	8	9	10	11	12	13	14	15	16	17	18		
1	1	2																		2
	H	He																		
2	3	4											5	6	7	8	9	10		
	Li	Be											B	C	N	O	F	Ne		
3	11	12	3	4	5	6	7	8	9	10	11	12	13	14	15	16	17	18		
	Na	Mg											Al	Si	P	S	Cl	Ar		
4	19	20	21	22	23	24	25	26	27	28	29	30	31	32	33	34	35	36		
	K	Ca	Sc	Ti	V	Cr	Mn	Fe	Co	Ni	Cu	Zn	Ga	Ge	As	Se	Br	Kr		
5	37	38	39	40	41	42	43	44	45	46	47	48	49	50	51	52	53	54		
	Rb	Sr	Y	Zr	Nb	Mo	Tc	Ru	Rh	Pd	Ag	Cd	In	Sn	Sb	Te	I	Xe		
6	55	56	57	72	73	74	75	76	77	78	79	80	81	82	83	84	85	86		
	Cs	Ba	La*	Hf	Ta	W	Re	Os	Ir	Pt	Au	Hg	Tl	Pb	Bi	Po	At	Rn		
7	87	88	89	104	105	106	107	108	109	110	111	112	113	114	115	116	117	118		
	Fr	Ra	Ac**	Rf	Db	Sg	Bh	Hs	Mt	Ds	Rg	Cn	Uut	Ff	Mcc	Lv	Ts	Og		

*Lanthanoides 6	58	59	60	61	62	63	64	65	66	67	68	69	70	71
	Ce	Pr	Nd	Pm	Sm	Eu	Gd	Tb	Dy	Ho	Er	Tm	Yb	Lu
**Actinoides 7	90	91	92	93	94	95	96	97	98	99	100	101	102	103
	Th	Pa	U	Np	Pu	Am	Cm	Bk	Cf	Es	Fm	Md	No	Lr

Trends of electronegativity:

- A qualitative measure of the ability of an atom in a chemical compound to attract shared electrons to itself is called electronegativity.
- Electronegativity increases across a period because of the number of charges on the nucleus increases. That attracts the bonding pair of electrons more strongly.
- Electronegativity decreases across moving down in a group, due to an increase in the distance between the nucleus and the valence electron shell.

Explanation:

The electronegativity of different elements is given as

Electronegativity Values (on Pauling scale) Across the Periods

Atom (Period II)	Li	Be	B	C	N	O	F
Electromagativity	1.0	1.5	2.0	2.5	3.0	3.5	4.0
Atom (Period III)	Na	Mg	Al	Si	P	S	Cl
Electromagativity	0.9	1.2	1.5	1.8	2.1	2.5	3.0

Electronegativity decreases down the group and increases from left to right in a period.

So Lithium (Li) has least electronegativity based on the trends and Carbon has the highest electronegativity.

The correct order of electronegativity hence is

$\text{Li} < \text{Mg} < \text{Be} < \text{C}$

95. Answer: c

Explanation:

The given reaction is between p-methyl benzoic acid and 1 equivalent This is an example of bromination reaction. In this reaction, bromination of p-methyl benzoic acid takes place at meta position. This is because, $-\text{COOH}$ is a group which is meta directing in nature. So, it deviates incoming group towards its meta position.

In addition to this, methyl group is a group ortho-para directing in nature. So, in this reaction, both the substituents, that is, carboxyl and methyl group, directs the incoming group towards the same position. Hence, the organic formed in this reaction will be 3-bromo-4-methyl benzoic acid.

The reaction equation can be drawn as follows,

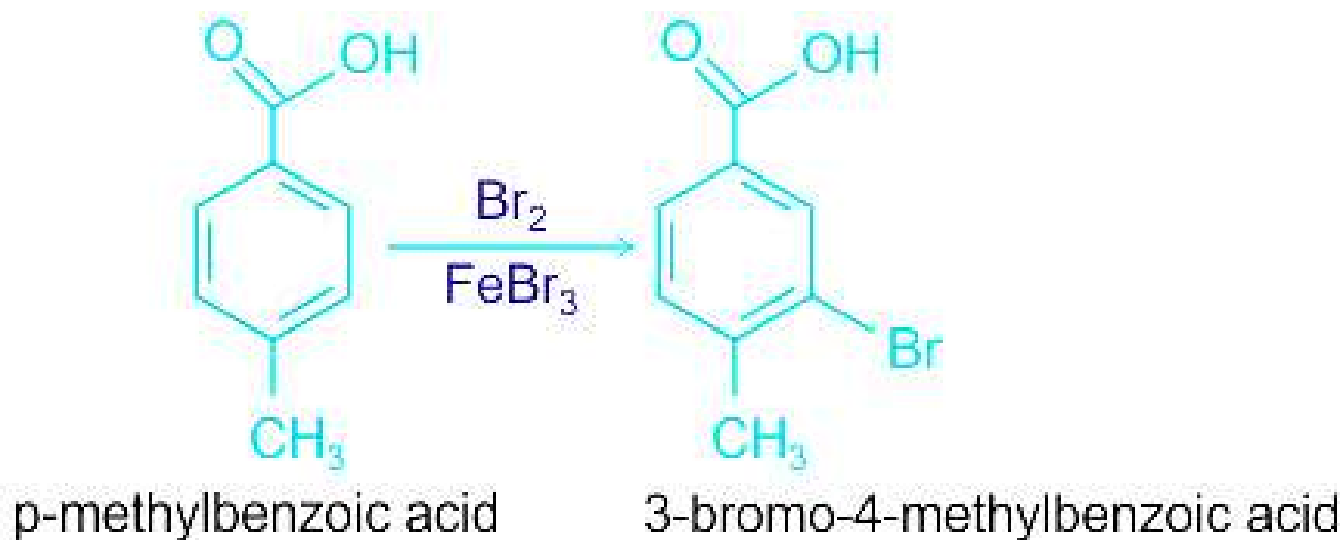

96. Answer: d

Explanation:

The correct answer is Because crystalization of virus is possible.

Concept:

- A virus is a group of **ultramicroscopic, non-cellular, highly infectious agents** that multiply only intracellularly inside the living host cells without involving growth and divisions.
- Viruses reproduce only inside the cells of the host organism, which may be a bacterium, plant or animal.
- The inert virus outside the cell wall is called **viron** .
- Outside the host cells, they are inert particles.
- It is very difficult to ascertain whether they are living or non-living.

★ Key Points

- Properties of the virus suggest that it is **abiotic** are-
 - The viruses are **non-cellular organisms** that are characterized by having an **inert crystalline structure** outside the living cell.
 - They **do not show cellular metabolism** and lack respiration.
 - They possess **high specific gravity** , unlike living organisms.

- The viruses can be precipitated just like chemical substances.
- Properties of the virus suggest that it is **biotic** are-
 - They have a **definite shape** and **morphology** like that of a living organism.
 - In addition to proteins, viruses also **contain genetic material** , which could be either **RNA** or **DNA** .
 - No virus contains both RNA and DNA.
 - They show the property of **mutation** .

97. Answer: d

Explanation:

The correct answer is Nitrogen cycle.

★ Key Points

- Nostoc presence in farm land can contribute in Nitrogen cycle.
- Nostoc are **free-living nitrogen-fixers** .
- The role of Nostoc is to **supply nutrients to the plants** that they cannot acquire from the air.
- It can utilize nitrogen in the form of nitrogen (N_2), available abundantly in the air.
- It is a **cyanobacterium** that **helps in the nitrogen fixation process** .

Explanation:

Nitrogen Cycle-

The process of cycle of events by which **free atmospheric nitrogen gets converted into its various chemical forms** is called Nitrogen cycle.

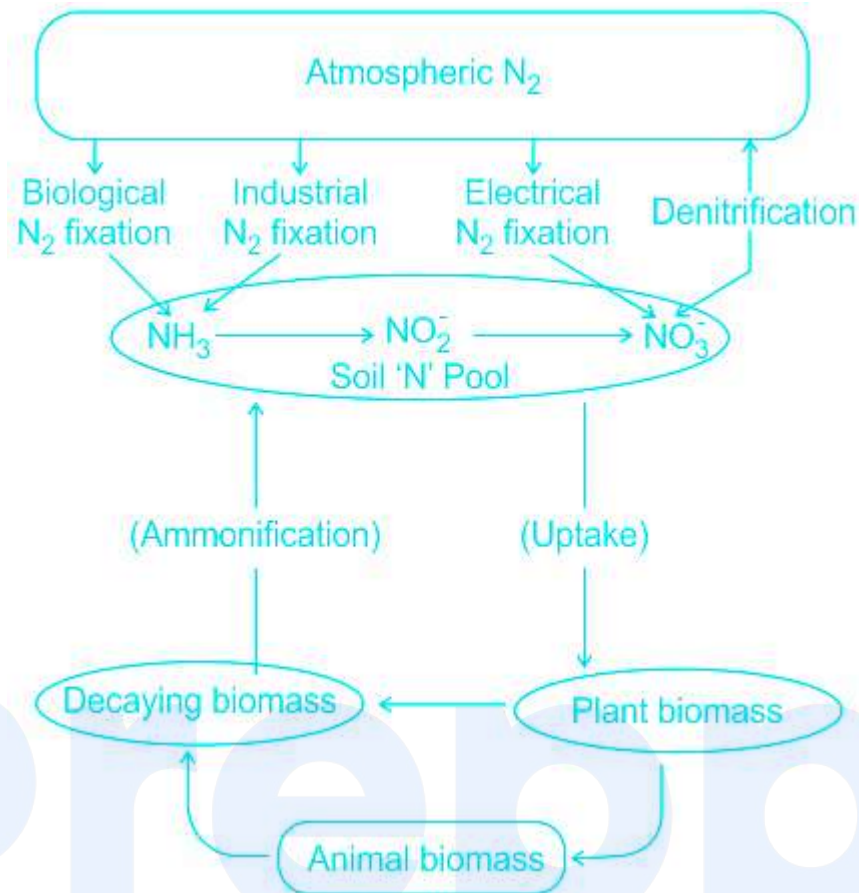

Nitrogen fixation process

- In this process, the **atmospheric nitrogen is fixed** which is to be used by plants.
- In this step, the **molecular nitrogen is converted into inorganic nitrogenous compounds** like nitrite, nitrate, and ammonia.
- Nitrogen fixation is of two types-
- **Physical nitrogen fixation-**
 - The process of conversion of N_2 to **inorganic nitrogenous compounds without the involvement of microorganisms** is called physical nitrogen fixation.



- **Biological nitrogen fixation-**

- The process in which **atmospheric nitrogen gets converted into inorganic nitrogenous compounds through microorganisms** are called biological nitrogen fixation.
- Very few organisms can utilize atmospheric nitrogen, only certain prokaryotes are capable of fixing nitrogen.
- **Reduction of nitrogen to ammonia by living organisms** is called **Biological nitrogen fixation** .
- The enzyme, **nitrogenase** which is capable of N_2 reduction is present in prokaryotes. such microbes are called N_2 - *fixers* .



Thus, **Nostoc presence in farm land contribute in Nitrogen cycle** .

98. **Answer: b**

Explanation:

Concept:

Prokaryotic Cell -

- The cells having nuclear material without a nuclear membrane are termed prokaryotic cells .
- The organisms with these kinds of cells are called prokaryotes (pro: primitive; karyon: nucleus).
- Examples of prokaryotes are bacteria and blue-green algae .

Eukaryotic cell -

- The cells having a well-organized nucleus with a nuclear membrane are designated as eukaryotic cells.
- All organisms other than bacteria and blue-green algae are called eukaryotes. (eu : true; karyon: nucleus).

Explanation:

- The infectious agent of small size and simple composition can multiply only in living cells of animals, plants, or bacteria.
- They behave as non-living objects when they are independent.
- When they enter living cells, they start to reproduce as living beings by cell multiplication.
- They can cause various diseases in human beings, other animals, and in plants.
- Tobacco Mosaic Virus (TMV) is a single-stranded RNA virus that commonly infects Solanaceous plants, which is a plant family that includes many species such as petunias, tomatoes, and tobacco.
- **TMV is the only virus among the given options, so it is the correct option.**

★ **Additional Information**

- Nostoc is a type of blue-green algae and prokaryote.
- *Saccharomyces cerevisiae*, also known as baker's yeast, is one of the model organisms studied in laboratories worldwide. It is a eucaryote.
- E. Coli is a prokaryotic cell. E. Coli is commonly found in the Intestine of humans and animals with warm blood.

99. Answer: a

Explanation:

Concept-

- Chromosomes carry genes and help in the inheritance or transfer of characters from the parents to the offspring. The chromosomes can be seen only when the cell divides.
- Chromatin contains DNA and some basic proteins called histones, some non-histone proteins, and also RNA.
- A single human cell has approximately two-meter-long threads of DNA distributed among its forty-six (twenty-three pairs) chromosomes.
- Every chromosome essentially has a primary constriction of the centromere on the sides of which disc-shaped structures called kinetochores are present.

Explanation-

- Based on the position of the centromere, the chromosomes can be classified into four types.
 - (1) Metacentric (2) Sub-metacentric (3) Acrocentric (4) Telocentric
- The **metacentric** chromosome has a middle centromere forming two equal arms of the chromosome.
- Both the **arms** are the same in size of this chromosome.

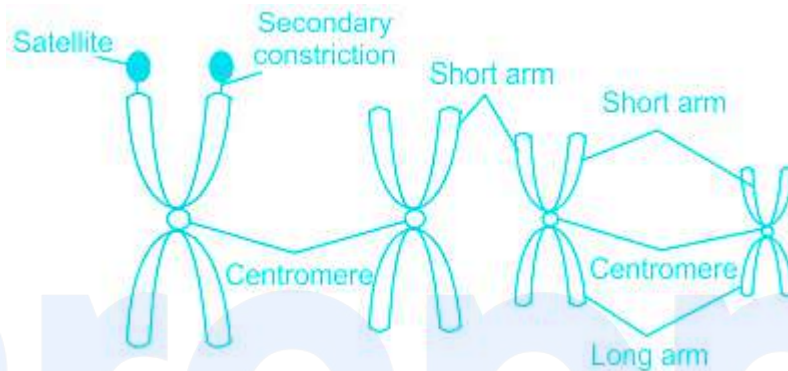

Therefore in metacentric conditions both the arms of a chromosome are the same.

★ Additional Information

- **Submetacentric** : The sub-metacentric chromosome has a centromere slightly away from the middle of the chromosome resulting in one shorter arm and one long arm.
- **Acrocentric** : The acrocentric chromosome the centromere is situated close to its end forming one extremely short and one very long arm.
- **Telocentric** : The telocentric chromosome has a terminal centromere.

100. Answer: b

Explanation:

Explanation:

- Structurally, lysosomes are membrane-bound sacs filled with digestive enzymes.

- These enzymes are made by RER (Rough Endoplasmic Reticulum).
- Lysosomes are a kind of waste disposal system of the cell.
- They help to keep the cell clean by digesting any foreign material as well as worn-out cell organelles.
- During the disturbance in cellular metabolism, for example, when the cell gets damaged, lysosomes may burst and the enzymes digest their own cell. Therefore, lysosomes are also known as the 'suicide bags' of a cell.

So the correct option is Lysosome

★ **Additional Information**

- Centrosomes are organelles that serve as the main microtubule-organizing centres for animal cells. Centrosomes are made up of two, barrel-shaped clusters of microtubules called 'centrioles'.
- Ribosomes are macromolecular machines, found within all living cells, which perform biological protein synthesis.

101. **Answer: b**

Explanation:

Concept:

Ore is a mineral from which metals can be extracted profitably.

Explanation:

Ore	Composition
Magnetite	Magnetite is a mineral and one of the main iron ores. With the chemical formula Fe_3O_4 .
Petalite	$\text{LiAlSi}_4\text{O}_{10}$ (Ore of Lithium)
Limonite	Is an iron ore and it is a mixture of hydrated iron(III) oxide-hydroxides
Hematite	It is basically ferric oxide (Fe_2O_3), ore of Iron

Petalite is an ore of Lithium not iron. So, it is the correct option.

★ Additional Information

- Petalite is a lithium aluminium silicate
- It is from the silicate class of minerals.
- Its crystal system is monoclinic.
- It crystallises relatively rarely and most often occurs as large cleavable masses.
- It can have the colour white, colourless, grey, pinkish or yellow.
- Colourless pieces can be faceted into exceptionally.

102. Answer: b

Explanation:

Explanation:

Alloys:

- Alloys are basically a homogenous mixture of a metal with another metal or non-metal.
- This is done to change the property of metals or improvise some of the qualities.
- The alloys can make metal rust-free, can enhance its, strength, and make it more useful for certain purposes. For example, steel, an alloy of iron has more

strength than alloy and is rust-free. Hence it is used for construction purposes.

Alloy	Composition	Uses
(1) Brass	Copper and zinc	Making Utensils, Locks, gears
(2) solder	Lead and Tin	Electronics, heating, etc
(3) Gun metal	Copper, Tin, and Zinc	Gears, casting, valves
(4) Nichrome	Nickel, Iron, and Chromium	Heating, toasters, and space heaters

Solder is the alloy of lead and tin but in question, it is Lead and zinc. So it is the correct option.

103. Answer: c

Explanation:

Concept:

Alcohol dehydration:

- Alcohols can undergo dehydration (i.e, removal of a molecule of water) to form alkenes.
- This is possible in the treatment of alcohol with a protic acid .

E.g., $\text{con.H}_2\text{SO}_4$ or H_3PO_4 , or catalysts like anhydrous zinc chloride or alumina.

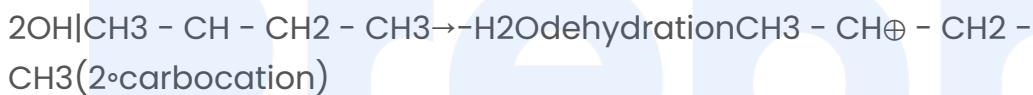
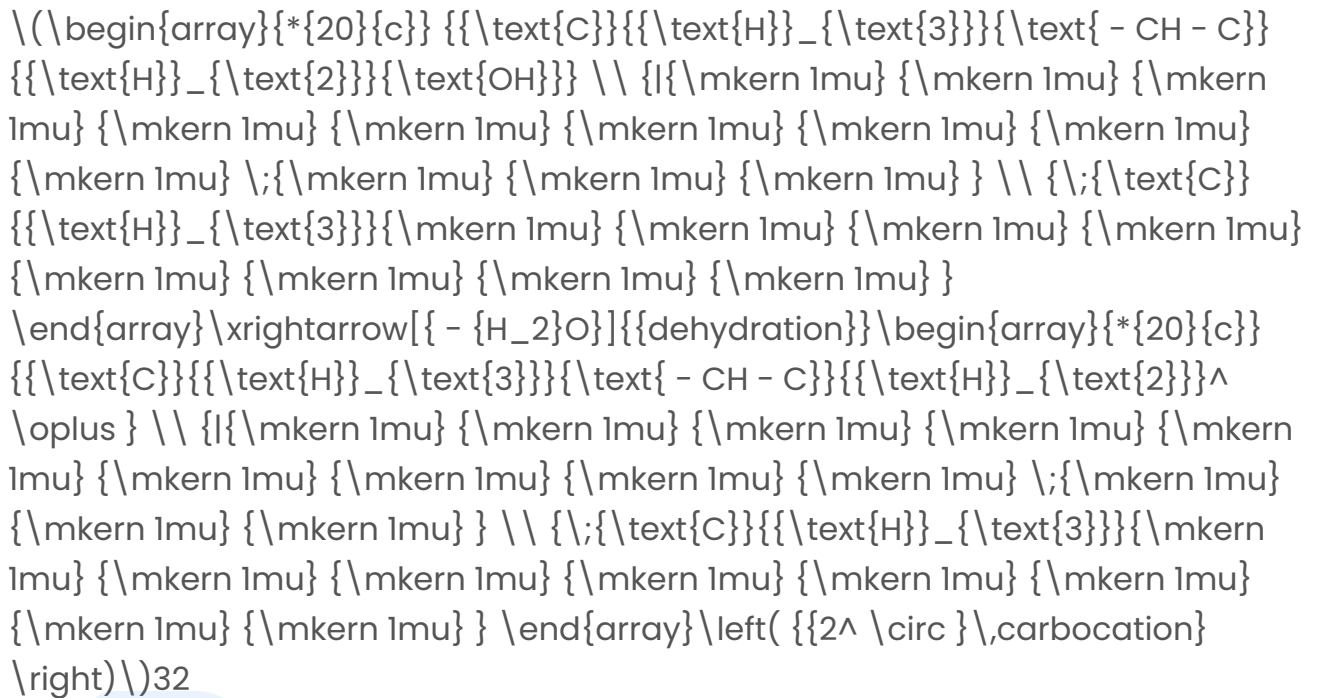

2,



$\left(\text{3}^\circ \text{ carbocation} \right)$

3.



4.

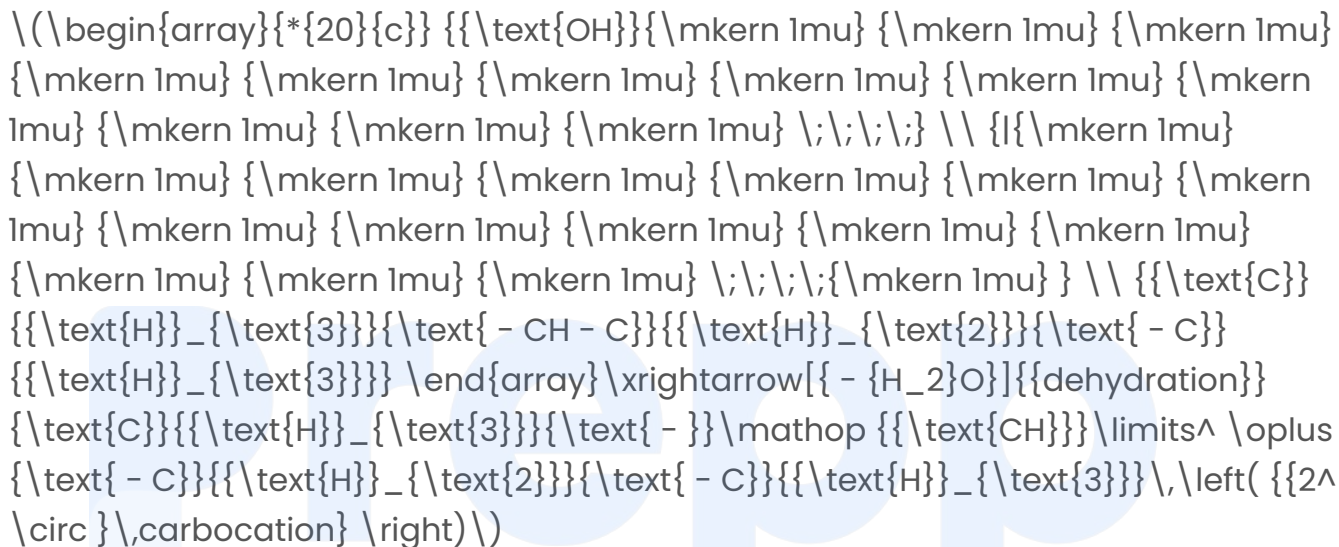

The increasing order of stability of carbocation is:



On the basis of the Inductive (+I) effect, among the above carbocations formed by dehydration, the most stable is the tertiary carbocation.

Hence, $\text{CH}_3\text{C(CH}_3)_2\text{OH}$ (t-Butyl alcohol) on dehydration forms the most stable (t-Butyl cation [3°]) carbonium ion.

★ **Additional Information**

Alcohol Dehydration:

The mechanism of dehydration of alcohol (eg: ethanol) involves the following steps:

Step 1: Formation of protonated alcohol.

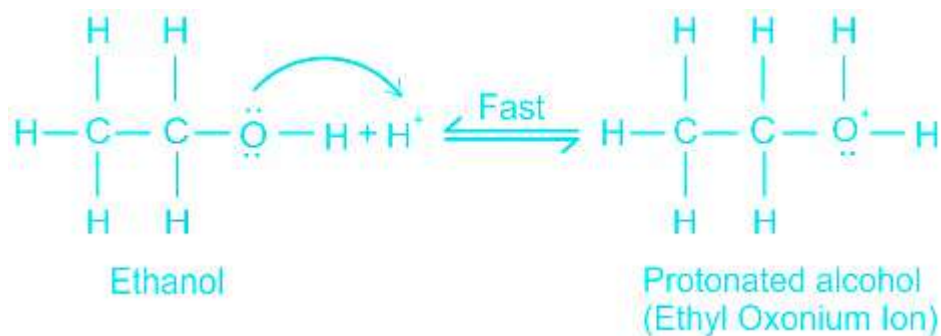

Step 2: Carbocation formation: It is the slowest step and hence, the rate-determining step of the reaction.

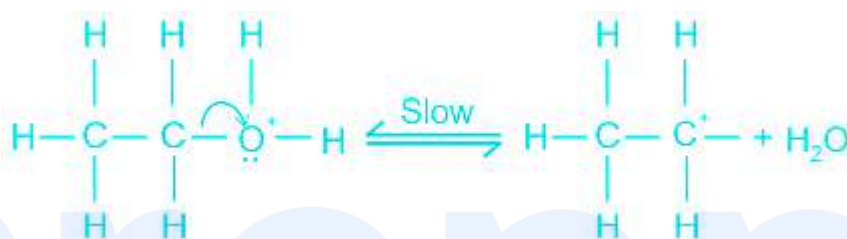

Step 3: Formation of ethene by the elimination of a proton. The acid utilized in step 1 is released in step 3. The equilibrium shifts to the right when ethene is removed as it is formed.

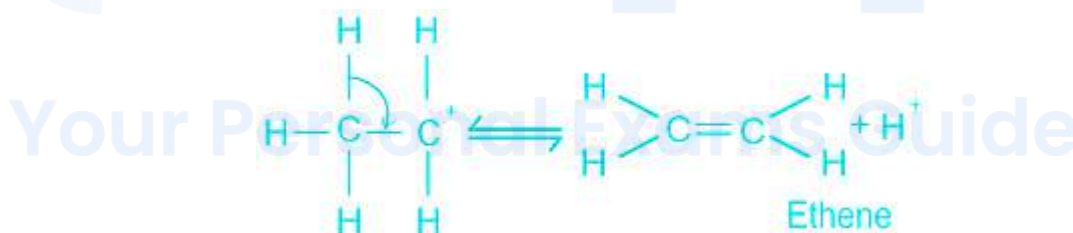

104. Answer: d

Explanation:

Concept:

- Acids are substances that taste sour.
- It turns litmus paper red.
- Acids are naturally present in citrus fruits like oranges, grapes, etc.

- It is also present in the ant's sting which causes irritation.
- Some naturally occurring acids and their source are listed in the below table.

Substance	Acid
Lemon \ Orange	Citric Acid
Ant Sting	Formic Acid
Vinegar	Acetic Acid
Curd	Lactic Acid
Grapes, Unripened Mangoes, tamarind	Tartaric acid
Amla (Vitamin C)	Ascorbic Acid
Spinach	Oxalic Acid

- From, the above chart, we can see that tartaric acid is present in Tartaric Acid.

105. Answer: b

Explanation:

The S_N2 reaction is a second order nucleophilic substitution reaction where the rate is dependent on the concentration of the substrate / alkyl halide and the nucleophile. S_N2 reactions occur with inversion of configuration and work well with methyl and primary substrates.

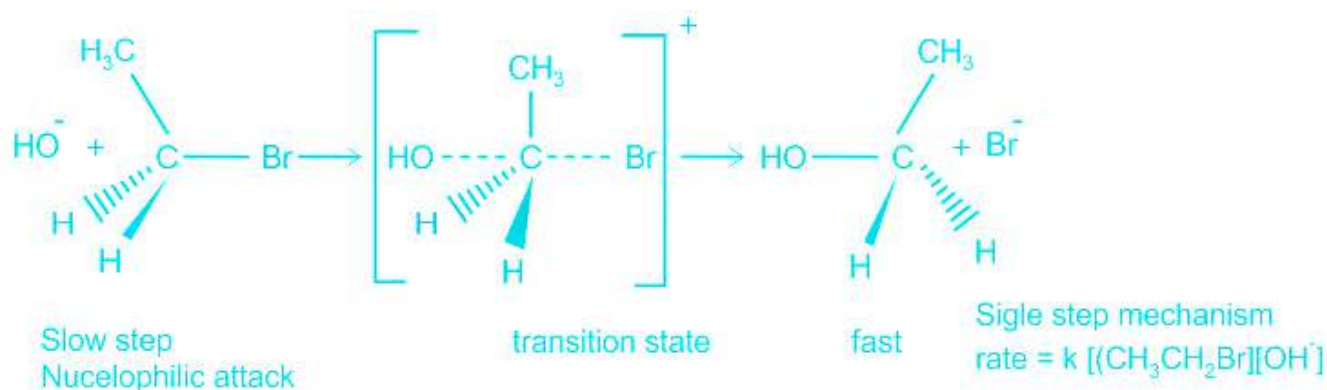

★ Key Points

Stereochemistry of SN2 Reactions

- There are two ways in which the nucleophile can attack the stereocenter of the substrate:
- **A frontside attack** where the nucleophile attacks from the same side where the leaving group is present, resulting in the **retention** of stereochemical configuration in the product.
- **A backside attack** where the nucleophile attacks the stereocenter from the opposite side of the carbon-leaving group bond, resulting in **inversion** of stereochemical configuration in the product.
- Since purely SN2 reactions show **100% inversion** in stereochemical configuration, it is clear that these Reactions occur through a backside attack

Reactivity order

- Reactivity of alkylhalides for SN2 reaction **increase** with the **decreasing order** of **electronegativity of halide group**.

Thus it is conclude that The order of reactivities of the following alkylhalides for SN2 reaction is $RI > RBr > RCl > RF$

106. **Answer: a**

Explanation:

Concept:

Thermal Expansion

- Whenever the solids, liquids, and gases are heated at some temperature, they start changing their shape and that process is known as Thermal Expansion.
- On heating, the average kinetic energy of the molecules increases and they start moving vigorously about their mean position.
- In the process, the intermolecular spacing increases and the material expands in all directions.

- Coefficient of thermal expansion: The coefficient of thermal expansion is a property of any material.

Explanation:

- When the hole is heated, it keeps expanding from all sides.
- This is as the metal copper will expand linearly from all sides.
- So overall the hole size will increase.

★ **Additional Information**

Linear expansion	<ul style="list-style-type: none"> • It is the change in one dimension (length) due to a change in temperature (ΔT). • The coefficient of linear expansion is α. 	Change in length, $\Delta L = L \alpha \Delta T$
Superficial expansion	<ul style="list-style-type: none"> • It is the change in two dimensions (area) due to a change in temperature (ΔT). • The coefficient of linear expansion is β. 	Change in area, $\Delta A = A \beta \Delta T$
Cubical expansion	<ul style="list-style-type: none"> • It is the change in three dimensions (volume) due to a change in temperature (ΔT). It is also called volumetric expansion. • The coefficient of linear expansion is γ. 	Change in volume, $\Delta V = V \gamma \Delta T$

107. Answer: b

Explanation:

★ **Key Points**

- Meter is the SI unit of length.
- Nano means the quantity is 10^{-9} of the standard quantity.
- The nanometer is 10^{-9} meters.

Calculation:

- Since $1 \text{ mm} = 10^{-3} \text{ m}$ also, $1 \text{ cm} = 10^{-2} \text{ m}$
- $1 \text{ nanometer} = 10^{-9} \text{ m} = 10^{-3} \times 10^{-9} \text{ mm} = 10^{-6} \text{ millimeter}$

Also,

- Since, $1 \text{ cm} = 10^{-2} \text{ m}$
- So, $1 \text{ nanometer} = 10^{-9} \text{ m} = 10^{-2} \times 10^{-9} \text{ cm} = 10^{-7} \text{ centimeter}$

★ **Mistake Points**

Here it has been asked the relationship between nanometer and millimeter, not meter.

★ **Additional Information**

prepp

Your Personal Exams Guide

SI Prefix		
Prefix	Symbol	Multiplier
exa	E	10^{18}
peta	P	10^{15}
tera	T	10^{12}
giga	G	10^9
mega	M	10^6
kilo	k	10^3
hecto	h	10^2
deca	da	10^1
deci	d	10^{-1}
centi	c	10^{-2}

Prepp
Your Personal Exams Guide

mili	m	10^{-3}
micro	μ	10^{-6}
nano	n	10^{-9}
angstrom	Å	10^{-10}
pico	p	10^{-12}
femto	f	10^{-15}
atto	a	10^{-18}

108. Answer: c

Your Personal Exams Guide

Explanation:

★ Key Points

- The phenomenon in which electrical energy is produced by means of thermal energy is called the thermoelectric effect .
- The thermocouple is an electrical device containing junctions of two dissimilar metal joints. It is used as temperature sensors.
- It works on the principle of the thermoelectric effect or Seebeck effect which states that the temperature difference between two dissimilar electric conductors produces a voltage difference between them.
- This potential difference is used to measure temperatures.

So the correct option is Thermocouple.

★ Additional Information

- Hydrometer: It works on the Archimedes principle. It is used to know the (specific) density of the fluid.
- Photocell: It converts solar energy into electrical energy.
- Voltmeter: It is the device used to measure the potential difference.

109. Answer: d

Explanation:

Concept:

- Conservative force: A force is conservative if the work done by the force in displacing an object from one point to another point is independent of the path followed by the object and depends only on the endpoints.
- Electrostatic forces , gravitational forces , elastic forces , magnetic forces, etc and are the examples of a conservative force .
- Non-conservative forces: A force is said to be non-conservative if work done by or against the force in moving a body from one position to another, depends on the path followed between these two positions.
- Example: Frictional force , Viscous force , Airdrag, etc .

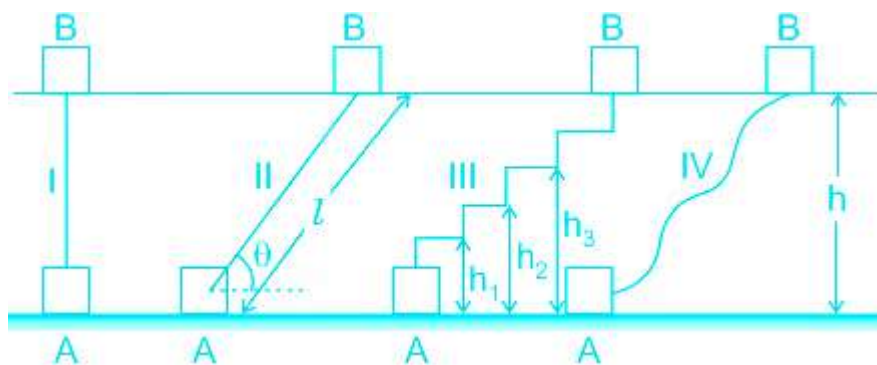

- If a body of mass m lifted to height h from the ground level by a different path, then the work done in each case will be the same. Therefore, in conservative force work done by the force in displacing an object from one point to another

point is independent of path followed by the object and depends only on the endpoints.

Explanation:

Viscous force (F):

- When a layer of fluid slips or tends to slip on adjacent layers in contact. the two layers exert tangential force on each other which tries to destroy the relative motion between them.
- The property of a fluid due to which it opposes the relative motion between its different layers is called viscosity (or fluid friction or internal friction) and the force between the layers opposing the relative motion is called viscous force .
- This is basically a frictional force and hence a non-conservative force.

110. **Answer: c**

Explanation:

Explanation:

- The intensity of a sound depends upon the loudness which depends upon amplitude.
- The shrillness of a sound depends upon its pitch.
- Examples of the high pitched sound is of the sound of a bird, or a good singer.
- The low pitched sound is sounds that not much pleasant like shouting or roaring,
- So roaring is loud, it is having high intensity but the sound of roaring is low pitched.

high intensity and low pitch is correct.

111. **Answer: a**

Explanation:

Formula Used:

The radius of incircle = $\frac{1}{2}$ (Side of the square)

The radius of circumcircle = $\frac{1}{2}$ (Diagonal of the square)

Area of the square = (Side)²

Diagonal of the square = $\sqrt{2} \times$ Side

Area of circle = πr^2

Calculation:

Let the side of the square be = x

The radius of incircle = $\frac{1}{2}$ (Side of the square)

⇒ The radius of incircle = $\frac{x}{2}$

Area of incircle = $\pi(\frac{x}{2})^2 = \frac{\pi x^2}{4}$

The radius of circumcircle = $\frac{1}{2}$ (Diagonal of the square)

⇒ Diagonal of the square = $\sqrt{2}x$

⇒ The radius of circumcircle = $\frac{1}{2} \times \sqrt{2}x = \frac{x}{\sqrt{2}}$

⇒ Area of circumcircle = $\pi(\frac{x}{\sqrt{2}})^2 = \frac{\pi(x)^2}{(\sqrt{2})^2} = \frac{\pi x^2}{2}$

⇒ Area of incircle : Area of circumcircle = $\frac{\pi x^2}{4} : \frac{\pi x^2}{2}$

∴ Area of incircle : Area of circumcircle = 1 : 2

The correct option is 1 i.e. 1 : 2

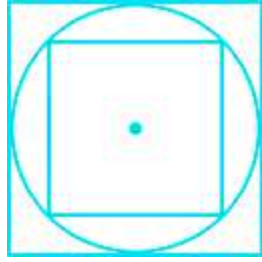

112. Answer: c

Explanation:

Concept:

Formula of percentage = $(\text{Value}/\text{Total value}) \times 100\%$

Calculation:

The number of students obtaining more than 10 marks and less than or equal to 40 marks = $4 + 6 + 3 = 13$

Total number of students = $2 + 4 + 6 + 3 + 3 + 2 = 20$

\therefore Percentage = $(13/20) \times 100 = 65\%$

Hence, the percentage of students obtaining more than 10 and less than or equal to 40 marks is 65%.

113. Answer: b

Explanation:

Concept:

- $\sin^2 x + \cos^2 x = 1$
- $\tan x = \sin x / \cos x$
- $\tan^{-1} x + \tan^{-1} y = \tan^{-1} \left(\frac{x+y}{1-xy} \right)$

Calculation:

We have, $\sin^{-1} \frac{5}{13} + \cos^{-1} \frac{3}{5}$

Let $x = \sin^{-1} \frac{5}{13}$

$$\Rightarrow \sin x = \frac{5}{13}$$

$$\Rightarrow \cos x = \sqrt{1 - \frac{25}{169}} \quad (\because \cos x = \sqrt{1 - \sin^2 x})$$

$$\Rightarrow \cos x = \frac{12}{13}$$

$$\therefore \tan x = \sin x / \cos x = 5/12$$

$$\Rightarrow x = \tan^{-1} \frac{5}{12} \quad \text{-----(1)}$$

Similarly, let $y = \cos^{-1} \frac{3}{5}$

$$\Rightarrow \cos y = \frac{3}{5}$$

$$\Rightarrow \sin y = \sqrt{1 - \frac{9}{25}} \quad (\because \sin y = \sqrt{1 - \cos^2 y})$$

$$\Rightarrow \sin y = \frac{4}{5}$$

$$\therefore \tan y = 4/3$$

$$\Rightarrow y = \tan^{-1} \frac{4}{3} \quad \text{-----(2)}$$

Now, $\sin^{-1} \frac{5}{13} + \cos^{-1} \frac{3}{5}$

$$\Rightarrow x + y$$

$$\Rightarrow \tan^{-1} \frac{5}{12} + \tan^{-1} \frac{4}{3} \quad [\text{Using (1) \& (2)}]$$

$$\Rightarrow \tan^{-1} \left(\frac{\frac{5}{12} + \frac{4}{3}}{1 - \frac{5}{12} \times \frac{4}{3}} \right) \quad \because \tan^{-1} x + \tan^{-1} y = \tan^{-1} \left(\frac{x+y}{1-xy} \right)$$

$$\Rightarrow \tan^{-1} \frac{63}{16}$$

114. Answer: d

Explanation:

Quadrilateral: It is a closed two-dimensional shape that has 4 sides, 4 angles and 2 diagonals. Quadrilaterals will typically be of standard shapes with four sides like rectangle, square, trapezoid.

Quadrilateral Properties:

- The total of its interior angles = 360 degrees.
- A quadrilateral is a plane figure made with four line segments closing in a space.
- Sides and angles can be equal or unequal.
- A quadrilateral with four equal sides and four right angles is a square.
- When two or four sides are equal, you get special types of quadrilaterals such as trapezoids and rectangles.
- Parallelogram, trapezium, rhombus are other examples of quadrilaterals.

To Draw a Quadrilateral Minimum 5 Components are Required:

- 4 Sides and 1 Diagonal
- 3 Sides and 2 Diagonal
- 2 Adjacent Sides and 3 Angles
- 3 Sides and 2 Included Angles

Hence, from the above-mentioned points, it becomes clear that the minimum number of 5 components required for the construction of a quadrilateral.

115. Answer: b

Explanation:

Calculation:

$$\sqrt{0.9} = 0.949$$

$$0.9 = 0.9$$

$$(0.9)^2 = 0.81$$

$$(0.9)^3 = 0.729$$

Ascending order

$$\Rightarrow 0.729 < 0.81 < 0.9 < 0.949$$

$$\Rightarrow (0.9)^3 < (0.9)^2 < 0.9 < \sqrt{0.9}$$

\therefore The largest number is $\sqrt{0.9}$

The correct option is 1 i.e. $\sqrt{0.9}$

116. Answer: b

Explanation:

Concept:

From the law of exponent,

$$a^0 = 1$$

Calculation:

$$\text{We have } a^{2n^2+2} = 1$$

$$\Rightarrow a^{2n^2+2} = a^0$$

$$\Rightarrow 2n^2 + 2 = 0$$

$$\Rightarrow 2n^2 = -2$$

$$\Rightarrow n^2 = -1$$

$$\Rightarrow n = i$$

Thus, there is no real value of n for which the given equation has a solution.

117. Answer: d

Explanation:

Concept:

The two **concentric circles** are given by,

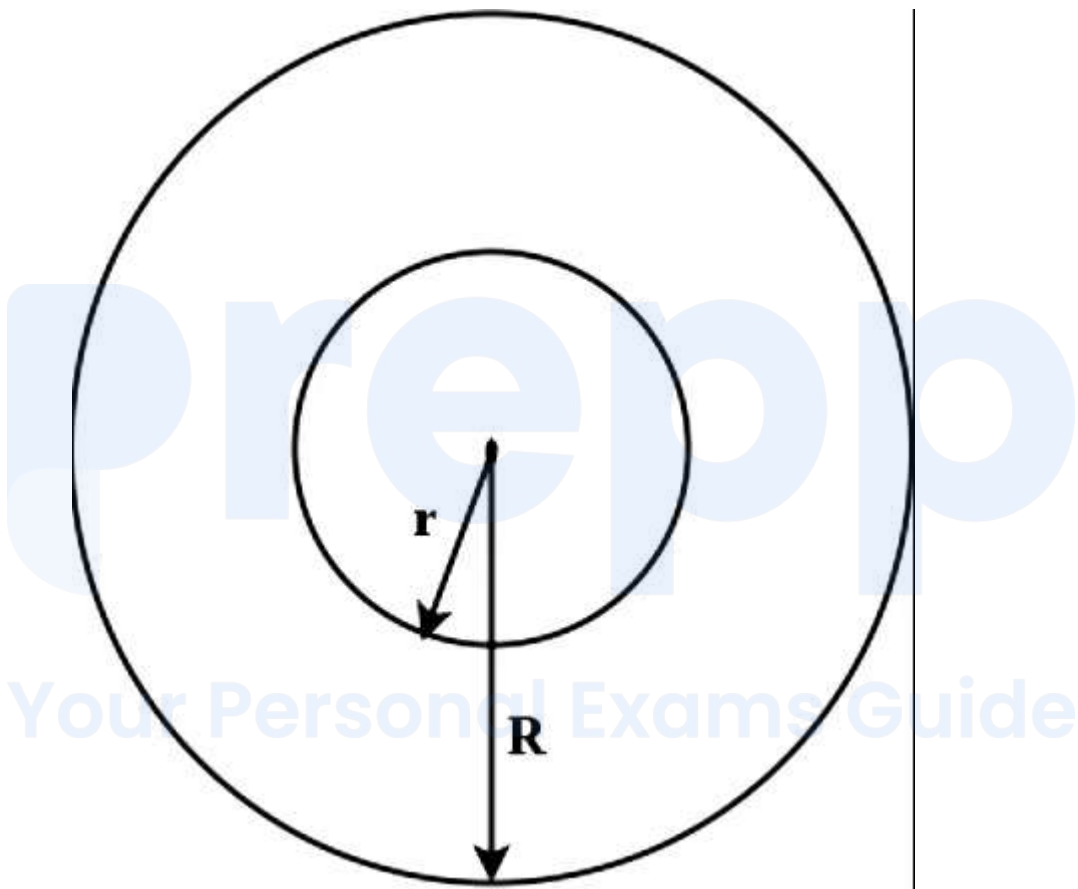

When two circles **touch externally**,

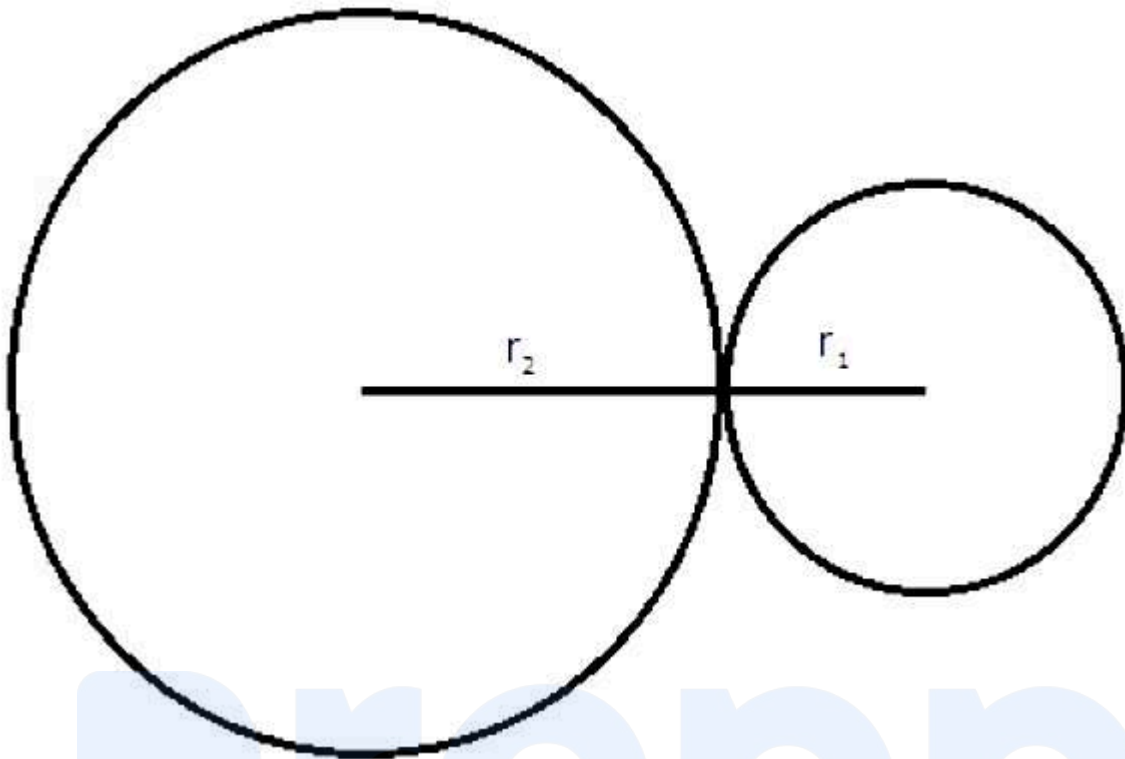

Calculation:

Let the radius of the bigger circle be R and that of the smaller circle be r .

The difference of the radius of two concentric circles is given by,

$$R - r = 2 \quad \text{----(1)}$$

When the circles are touching externally, the equation is given by,

$$R + r = 8 \quad \text{----(2)}$$

On solving equations (1) & (2), we get,

$$R = 5 \text{ and } r = 3$$

Hence, the radius of the bigger circle is 5.

118. Answer: a

Explanation:

Explanation:

It is given that $p(n) = x^{3^n} + y^{3^n}$ is divisible by $x + y$.

Let us put $n = 0$, we get

$$p(0) = x^{3^0} + y^{3^0}$$

$$\Rightarrow p(0) = x + y \quad (\because a^0 = 1)$$

$\Rightarrow p(0)$ is divisible by $x + y$

Now, let's put $n = 1$, we get

$$p(1) = x^3 + y^3$$

$$\Rightarrow p(1) = (x + y)(x^2 + y^2 - xy) \quad [\because x^3 + y^3 = (x + y)(x^2 + y^2 - xy)]$$

$\Rightarrow p(1)$ is divisible by $x + y$

Now, let's put $n = 2$,

$$p(2) = x^{3^2} + y^{3^2}$$

$$\Rightarrow p(2) = x^9 + y^9$$

$$\Rightarrow p(2) = (x^3 + y^3)(x^6 + y^6 - x^3y^3)$$

$\Rightarrow p(2)$ is divisible by $x + y$

Thus, we can say that $p(n)$ is divisible by $x + y$ for all values of $n \geq 0$, where n is an integer.

119. Answer: b

Explanation:

Explanation:

$$x - \frac{1}{x^2-9} = 3 - \frac{1}{x^2-9}$$

On multiplying the whole equation by $(x^2 - 9)$, we get

$$x^3 - 9x - 1 = 3x^2 - 27 - 1$$

$$\Rightarrow x^3 - 3x^2 - 9x + 27 = 0$$

Since the equation is a cubic equation. Therefore, the number of real solutions of the equations will be 3.

Hence, the number of real solutions of the equation $x - \frac{1}{x^2-9} = 3 - \frac{1}{x^2-9}$ will be 3.

120. Answer: d

Explanation:

Calculation:

$$x - y = 0$$

$$\Rightarrow x = y$$

$$f(y) = x^3 - 3x^2y + \lambda xy^2 + \mu y^3 = 0$$

$$\Rightarrow f(y) = y^3 - 3(y)^2y + \lambda(y)y^2 + \mu y^3 = 0$$

$$\Rightarrow f(y) = y^3 - 3y^3 + \lambda y^3 + \mu y^3 = 0$$

$$\Rightarrow -2y^3 + (\lambda + \mu)y^3 = 0$$

$$\Rightarrow \lambda + \mu = 2 \quad \dots\dots\dots(1)$$

$$y - 2x = 0$$

$$\Rightarrow y = 2x$$

$$\Rightarrow y/2 = x$$

$$\Rightarrow f(y) = x^3 - 3x^2y + \lambda xy^2 + \mu y^3 = 0$$

$$\Rightarrow f(y) = (y/2)^3 - 3(y/2)^2y + \lambda(y/2)y^2 + \mu y^3 = 0$$

$$\Rightarrow f(y) = \frac{y^3}{8} - \frac{3y^3}{8} + \frac{\lambda y^3}{2} + \mu y^3 = 0$$

$$\Rightarrow f(y) = y^3 - 6y^3 + 4\lambda y^3 + \mu y^3 = 0$$

$$\Rightarrow y^3 - 6y^3 + 4\lambda y^3 + 8\mu y^3 = 0$$

$$\Rightarrow 4(\lambda + 2\mu) = 5$$

$$\Rightarrow (\lambda + 2\mu) = 5/4 \quad \dots\dots\dots(2)$$

From equation (1) and (2)

$$\lambda = 11/4$$

$$\mu = -3/4$$

$$\therefore \lambda = 11/4 \text{ and } \mu = -3/4$$

The correct option is 3 i.e. 11/4 and -3/4

121. Answer: a

Explanation:

Concept:

- Area of the sector = $\frac{\theta}{360} \times \pi r^2$
- Area of triangle = $\frac{1}{2} \times \text{Base} \times \text{Height}$
- $\sin \theta = \text{perpendicular/hypotenuse}$
- $\cos \theta = \text{base/hypotenuse}$

Calculation:

$$\text{Area of the shaded region} = \text{Area of sector OABO} - \text{Area of } \Delta\text{OAB} \quad \text{-----(1)}$$

$$\text{Now, Area of sector OABO} = \frac{120}{360} \times \pi(42)^2 = 588\pi = 1848 \text{ cm}^2$$

Now, to calculate the area of ΔOAB , let's draw OM perpendicular to AB.

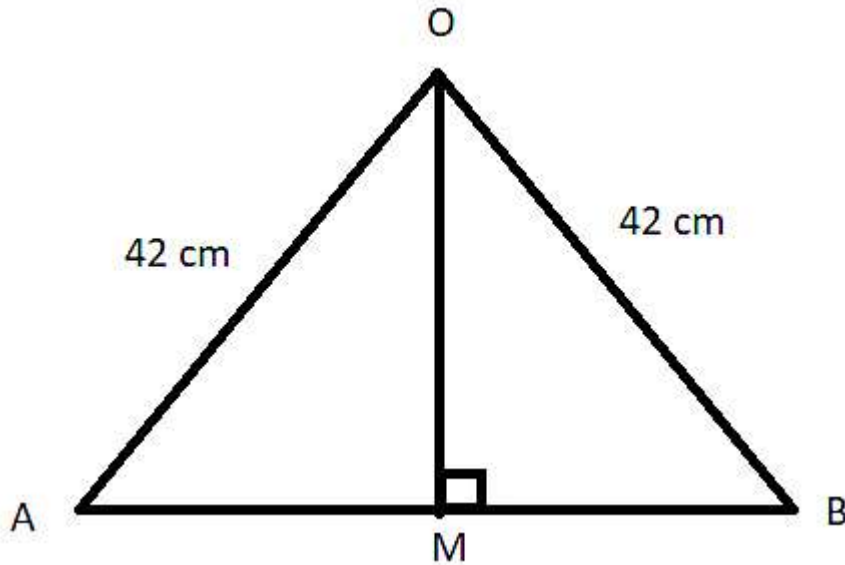

In $\triangle OMA$ and $\triangle OMB$, we have

$$\angle OMA = \angle OMB = 90^\circ$$

$$OA = OB = 42 \text{ cm (radius)}$$

$$OM = OM \text{ (common)}$$

$$\Rightarrow \triangle OMA \cong \triangle OMB \text{ (By RHS rule)}$$

$$\Rightarrow \angle AOM = \angle BOM = 120/2 = 60^\circ$$

$$\text{Also, } AM = BM \text{ (By CPCT)}$$

Now, in $\triangle OAM$,

$$\Rightarrow \sin O = AM/OA$$

$$\Rightarrow \sin 60^\circ = AM/42$$

$$\Rightarrow \sqrt{3}/2 = AM/42$$

$$\Rightarrow AM = 21\sqrt{3} \text{ cm}$$

$$\text{So, } AB = 2AM = 42\sqrt{3} \text{ cm}$$

$$\text{Also, } \cos O = OM/OA$$

$$\Rightarrow 1/2 = OM/42$$

$$\Rightarrow OM = 21 \text{ cm}$$

$$\text{So, area of } \triangle AOB = \frac{1}{2} \times AB \times OM = \frac{1}{2} \times 42\sqrt{3} \times 21 = 441\sqrt{3} \text{ cm}^2$$

$$\therefore \text{Area of shaded region} = 1848 - 441\sqrt{3} = 21(88 - 21\sqrt{3}) \text{ cm}^2$$

Hence, the area of the shaded region is $21(88 - 21\sqrt{3}) \text{ cm}^2$.

122. Answer: a

Explanation:

Concept:

According to **factor theorem**, if $f(x)$ is a polynomial of degree $n \geq 1$ and 'a' is any real number, then, $(x - a)$ is a factor of $f(x)$, if $f(a) = 0$.

Calculation:

Since $f(x) = px^3 + x^2 - 2x - q$ is exactly divisible by $(x - 1)$. Therefore, $(x - 1)$ is the factor of $f(x)$.

$$\Rightarrow p(1)^3 + (1)^2 - 2(1) - q = 0$$

$$\Rightarrow p + 1 - 2 - q = 0$$

$$\Rightarrow p - q = 1 \quad \text{-----(1)}$$

Also, $(x + 1)$ is the factor of $f(x)$

$$\Rightarrow p(-1)^3 + (-1)^2 - 2(-1) - q = 0$$

$$\Rightarrow -p + 1 + 2 - q = 0$$

$$\Rightarrow p + q = 3 \quad \text{-----(2)}$$

On solving equations (1) & (2), we get

$$p = 2, q = 1$$

123. Answer: a

Explanation:

Given:

Decrement in number of employees = 10 : 9

Increment in wages = 11 : 12

Formula Used:

The ratio of total expenditure = $\frac{\text{Number of workers before change} \times \text{Wage per worker before change}}{\text{Number of workers after change} \times \text{Wage per worker after change}}$

Calculation:

Let assume the number of employees before decrement = 10x

The number of employees after decrement = 9x

Wages before increment = 11y

Wages after increment = 12y

Ratio of total expenditure = $\frac{\text{Number of workers before change} \times \text{Wage per worker before change}}{\text{Number of workers after change} \times \text{Wage per worker after change}}$

$$\Rightarrow \text{Ratio of total expenditure} = \frac{10x \times 11y}{9x \times 12y}$$

$$\Rightarrow \text{Ratio of total expenditure} = 55 : 54$$

\therefore The ratio of total expenditure = 55 : 54

The correct option is 1 i.e. 55 : 54

124. Answer: c

Explanation:

Given:

$$(a + b) : (b + c) : (c + a) = 6 : 7 : 8$$

$$a + b + c = 14$$

Calculation:

$$(a + b) : (b + c) : (c + a) = 6 : 7 : 8$$

Let the constant be k

$$(a + b) = 6k \quad \dots\dots\dots(1)$$

$$(b + c) = 7k \quad \dots\dots\dots(2)$$

$$(c + a) = 8k \quad \dots\dots\dots(3)$$

By adding equation (1), (2) and (3)

$$2(a + b + c) = 21k$$

$$\Rightarrow a + b + c = 21k/2 \quad \dots\dots\dots(4)$$

$$a + b + c = 14 \quad \dots\dots\dots(5)$$

From equation (4) and (5)

$$\Rightarrow 14 = 21k/2$$

$$\Rightarrow 28 = 21k$$

$$\Rightarrow 4/3 = k$$

$$\Rightarrow (a + b) = 6 \times 4/3 = 8$$

$$a + b + c = 14$$

$$\Rightarrow c = 14 - 8 = 6$$

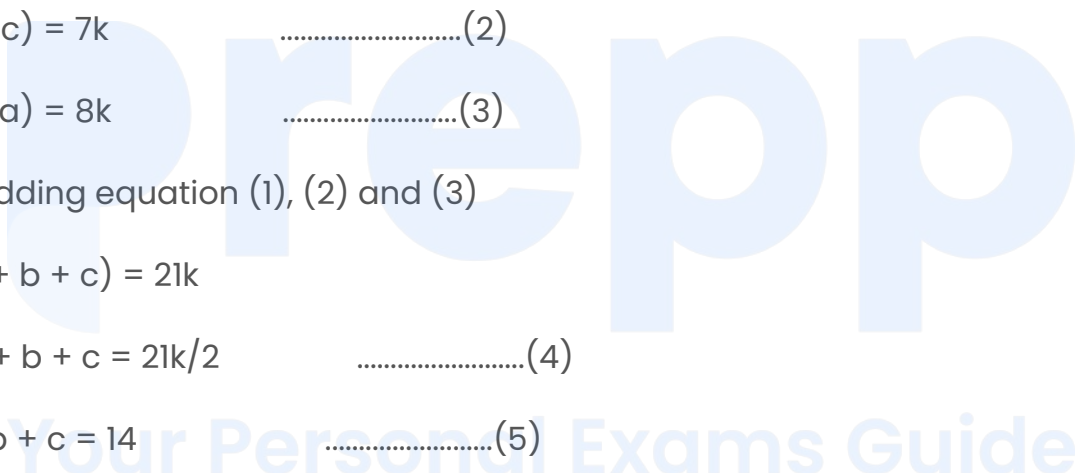

$$\Rightarrow (b + c) = 7 \times \frac{4}{3} = \frac{28}{3}$$

$$a + b + c = 14$$

$$\Rightarrow a = 14 - \frac{28}{3} = \frac{14}{3}$$

$$\Rightarrow (c + a) = 8 \times \frac{4}{3} = \frac{32}{3}$$

$$a + b + c = 14$$

$$\Rightarrow b = 14 - \frac{32}{3} = \frac{10}{3}$$

$$a : b : c$$

$$\Rightarrow \frac{14}{3} : \frac{10}{3} : 6$$

$$\Rightarrow \frac{14}{3} : \frac{10}{3} : \frac{18}{3}$$

$$\Rightarrow 14 : 10 : 18$$

$$\Rightarrow 7 : 5 : 9$$

$$\therefore a : b : c = 7 : 5 : 9$$

The correct option is 3 i.e. 7 : 5 : 9

Your Personal Exams Guide

125. Answer: d

Explanation:

Given:

$$\angle AOB = 60^\circ$$

Construction:

Join A and B. AB is a chord of the circle.

Mark point C on major arc.

Concept:

The sum of either pair of opposite angles of a cyclic quadrilateral is 180° .

If 2 angles are made on the same chord, then the angle at the center is twice the angle at circumference.

Calculation:

Chord of circle = Radius of circle

So, $\triangle AOB$ is an equilateral triangle ($OA = OB = AB$)

$$\angle AOB = 60^\circ$$

If 2 angles are made on the same chord, then the angle at the center is twice the angle at circumference.

$$\Rightarrow \angle AOB = 2\angle ACB$$

$$\Rightarrow 60^\circ = 2\angle ACB$$

$$\Rightarrow 30^\circ = \angle ACB$$

The sum of either pair of opposite angles of a cyclic quadrilateral is 180° .

$$\Rightarrow \angle ACB + \angle AEB = 180^\circ$$

$$\Rightarrow 30^\circ + \angle AEB = 180^\circ$$

$$\Rightarrow \angle AEB = 150^\circ$$

\therefore The angle subtended by the chord which is equal to the radius at any point of the minor arc of the circle is 150° .

The correct option is 3 i.e. 150°

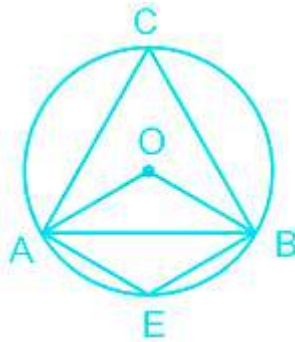

126. Answer: c

Explanation:

Calculation:

$$x^2 + |x| - 6 = 0$$

Case 1: When $x > 0$, then $|x| = x$

$$\Rightarrow x^2 + x - 6 = 0$$

$$\Rightarrow x^2 + 3x - 2x - 6 = 0$$

$$\Rightarrow x(x + 3) - 2(x + 3) = 0$$

$$\Rightarrow (x + 3)(x - 2) = 0$$

$$\Rightarrow x = -3, 2$$

Case 2: When $x < 0$, then $|x| = -x$

$$\Rightarrow x^2 - x - 6 = 0$$

$$\Rightarrow x^2 - 3x + 2x - 6 = 0$$

$$\Rightarrow x(x - 3) + 2(x - 3) = 0$$

$$\Rightarrow (x - 3)(x + 2) = 0$$

$$\Rightarrow x = 3, -2$$

Thus, the sum of real roots = $-3 + 2 + 3 - 2 = 0$

Hence, The sum of real roots of the equation $x^2 + |x| - 6 = 0$ is 0.

127. Answer: c

Explanation:

Concept:

The maximum value of $a \sin x + b \cos x = \sqrt{a^2 + b^2}$

Calculation:

The maximum value of $2 \sin x + 4 \cos x = \sqrt{2^2 + 4^2} = \sqrt{4 + 16} = \sqrt{20}$

\therefore Maximum value of the expression of $2 \sin x + 4 \cos x + 3 = \sqrt{20} + 3 = 2\sqrt{5} + 3$

Hence, the maximum value of the expression is $2\sqrt{5} + 3$.

128. Answer: c

Explanation:

Given:

Chord of circle = Radius of circle

Concept:

The sum of either pair of opposite angles of a cyclic quadrilateral is 180° .

If 2 angles are made on the same chord, then the angle at the center is twice the angle at circumference.

Calculation:

Chord of circle = Radius of circle

So, $\triangle AOB$ is an equilateral triangle ($OA = OB = AB$)

$$\angle AOB = 60^\circ$$

If 2 angles are made on the same chord, then the angle at the center is twice the angle at circumference.

$$\Rightarrow \angle AOB = 2\angle ACB$$

$$\Rightarrow 60^\circ = 2\angle ACB$$

$$\Rightarrow 30^\circ = \angle ACB$$

The sum of either pair of opposite angles of a cyclic quadrilateral is 180° .

$$\Rightarrow \angle ACB + \angle ADB = 180^\circ$$

$$\Rightarrow 30^\circ + \angle ADB = 180^\circ$$

$$\Rightarrow \angle ADB = 150^\circ$$

\therefore The angle subtended by the chord which is equal to the radius at any point of the minor arc of the circle is 150° .

The correct option is 3 i.e. 150°

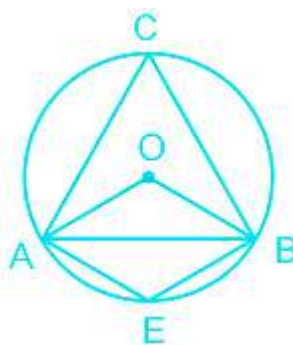

129. Answer: a

Explanation:

Given:

The volume of cone = Volume of the hemisphere

The base of cone = Base of the hemisphere

Formula Used:

Volume of cone = $\frac{1}{3} \times \pi r^2 h$

The volume of hemisphere = $\frac{2}{3} \times \pi r^3$

Calculation:

Let assume that radius of cone = R

Height of cone = H

The radius of hemisphere = r

⇒ Base of Cone = Base of Hemisphere

⇒ $2\pi R^2 = 2\pi r^2$

⇒ $R = r$

The volume of cone = Volume of the hemisphere

⇒ $\frac{1}{3} \times \pi R^2 H = \frac{2}{3} \times \pi r^3$

⇒ $\frac{1}{3} \times \pi r^2 H = \frac{2}{3} \times \pi r^3$

⇒ $H/r = 2/1$

∴ Height of cone : Radius of sphere = $H/r = 2 : 1$

The correct option is 1 i.e. 2 : 1

130. Answer: c

Explanation:

Calculation:

LCM of $\frac{1}{3}, \frac{5}{6}, \frac{2}{9}, \frac{4}{27}$

LCM of fractions = $\frac{\text{LCM of Numerator}}{\text{HCF of Denominator}}$

LCM of 1, 5, 2 and 4 = 20

HCF of 3, 6, 9 and 27 = 3

\Rightarrow LCM = $\frac{20}{3}$

\therefore LCM of $\frac{1}{3}, \frac{5}{6}, \frac{2}{9}, \frac{4}{27}$

The correct option is 3 i.e. $\frac{20}{3}$

131. **Answer: a**

Explanation:

Concept:

The **quadratic equation** having roots (α, β) is $x^2 - (\alpha + \beta)x + \alpha\beta = 0$.

- The **sum of the roots** of a quadratic equation is $\alpha + \beta = -\frac{b}{a} = -$ Coefficient of x / Coefficient of x^2 .
- The **product of the roots** of the quadratic equation is $\alpha\beta = \frac{c}{a} =$ Constant term / Coefficient of x^2 .

Calculation:

Let the roots of the equation be $2a$ and $3a$.

$$\Rightarrow 2a + 3a = -(-p)/1 = p$$

$$\Rightarrow 5a = p$$

$$\Rightarrow a = p/5 \quad \text{-----(1)}$$

$$\text{Also, } 2a \times 3a = 54/1 = 54$$

$$\Rightarrow 6a^2 = 54$$

$$\Rightarrow a^2 = 9$$

$$\Rightarrow a = 3$$

On putting the value of a in equation (1), we get

$$p = 15$$

132. Answer: b

Explanation:

Given:

Airthmetic mean = Geometric Mean

Formula Used:

$$\text{Airthmetic mean} = (x + y)/2$$

$$\text{Geometric Mean} = \sqrt{xy}$$

Where x and y are 2 numbers

Calculation:

$$\text{Airthmetic Mean} = (a + b)/2$$

$$\text{Geometric Mean} = \sqrt{ab}$$

According to question:

$$\sqrt{ab} = (a + b)/2$$

Squaring both the sides

$$ab = [(a + b)/2]^2$$

$$\Rightarrow 4ab = (a + b)^2$$

$$\Rightarrow 4ab = a^2 + b^2 + 2ab$$

$$\Rightarrow a^2 + b^2 - 2ab = 0$$

$$\Rightarrow (a - b)^2 = 0$$

$$\Rightarrow a - b = 0$$

$$\therefore a = b$$

The correct option is 2 i.e. $a = b$

133. Answer: b

Explanation:

Concept:

Distance formula for two points $A(x_1, y_1)$ and $B(x_2, y_2)$ is given by,

$$AB = \sqrt{(x_2 - x_1)^2 + (y_2 - y_1)^2}$$

Calculation:

Let $P(x, y)$ be the circumcentre.

$$\Rightarrow OP = AP = BP$$

$$\Rightarrow OP^2 = AP^2 = BP^2$$

$$\text{So, } OP^2 = AP^2$$

$$\Rightarrow (x - 0)^2 + (y - 0)^2 = (x - 0)^2 + (y - 3)^2$$

$$\Rightarrow x^2 + y^2 = x^2 + y^2 + 9 - 6y$$

$$\Rightarrow 6y = 9$$

$$\Rightarrow y = 3/2$$

Now, $OP^2 = BP^2$

$$\Rightarrow (x - 0)^2 + (y - 0)^2 = (x - 5)^2 + (y - 0)^2$$

$$\Rightarrow x^2 + y^2 = x^2 + 25 - 10x + y^2$$

$$\Rightarrow 10x = 25$$

$$\Rightarrow x = 5/2$$

Thus, the circumcentre is $(\frac{5}{2}, \frac{3}{2})$.

$$\text{Now, the circumradius} = OP = \sqrt{(\frac{5}{2} - 0)^2 + (\frac{3}{2} - 0)^2} = \sqrt{\frac{25}{4} + \frac{9}{4}} = \sqrt{\frac{34}{4}} = \frac{\sqrt{34}}{2}$$

Hence, the circumcentre and the circumradius are $(\frac{5}{2}, \frac{3}{2}), \frac{\sqrt{34}}{2}$.

134. Answer: c

Explanation:

Given :

Two coins are thrown

Concept used:

Total possible outcomes when two coins are thrown in the air are (HH), (HT), (TH), and (TT) i.e a total of 4 cases are possible

Formula used:

Probability $P(A) = \frac{\text{The number of favorable outcomes}}{\text{Total number of outcomes}}$

Calculation:

Total number of outcomes = 4

HH), (HT), (TH), and (TT)

Here, Head comes in 3 outcomes

Hence the probability of getting head = $\frac{3}{4}$

Hence the probability of **not getting a 'head'** = $1 - \frac{3}{4} = \frac{1}{4}$

Required probability = $\frac{1}{4}$

135. Answer: d

Explanation:

Explanation:

Since $0 < n < 1$,

$$\Rightarrow n^{10} > 1$$

Also, $n^{100} > 1$

As the exponent of n increases, the value will also increase.

$$\Rightarrow n^{10} < n^{100}$$

Also, $\frac{1}{n^{10}} > \frac{1}{n^{100}}$ ($\because n^{10} < n^{100}$)

Hence, option 4 is incorrect.

136. Answer: a

Explanation:

Formula used:

$$X (a + b) = X^c \text{ then, } (a + b) = c$$

Calculation:

$$\text{Let } 2^x = 3^y = 6^z = k$$

$$2^x = k \text{ then, } 2 = k^{1/x}$$

$$3^y = k \text{ then, } 3 = k^{1/y}$$

$$6^z = k \text{ then, } 6 = k^{1/z}$$

Now, We know that

$$2 \times 3 = 6$$

$$\Rightarrow k^{1/x} \times k^{1/y} = k^{1/z}$$

$$\Rightarrow k^{(1/x + 1/y)} = k^{1/z}$$

$$\Rightarrow 1/x + 1/y = 1/z$$

$$\Rightarrow -(1/x + 1/y) + 1/z = 0$$

Note:- The official question is wrong, the updated question and the solution is provided.

137. Answer: b

Explanation:

Given:

Product of two numbers = 32

Average of numbers = 6

Formula Used:

Average = Sum of all items / Number of items

Calculation:

Let assume that the first number is x

And the second number is y

According to the question:

$$x \times y = 32 \quad \dots\dots\dots(1)$$

$$(x + y)/2 = 6$$

$$\Rightarrow x + y = 12$$

$$\Rightarrow x = 12 - y \quad \dots\dots\dots(2)$$

From equation (1) and (2)

$$(12 - y) \times y = 32$$

$$\Rightarrow 12y - y^2 = 32$$

$$\Rightarrow y^2 - 12y + 32 = 0$$

$$\Rightarrow y^2 - 8y - 4y + 32 = 0$$

$$\Rightarrow (y - 8)(y - 4) = 0$$

$$y - 8 = 0$$

$$\Rightarrow y = 8$$

$$y - 4 = 0$$

$$\Rightarrow y = 4$$

If y = 8, Then x = 4

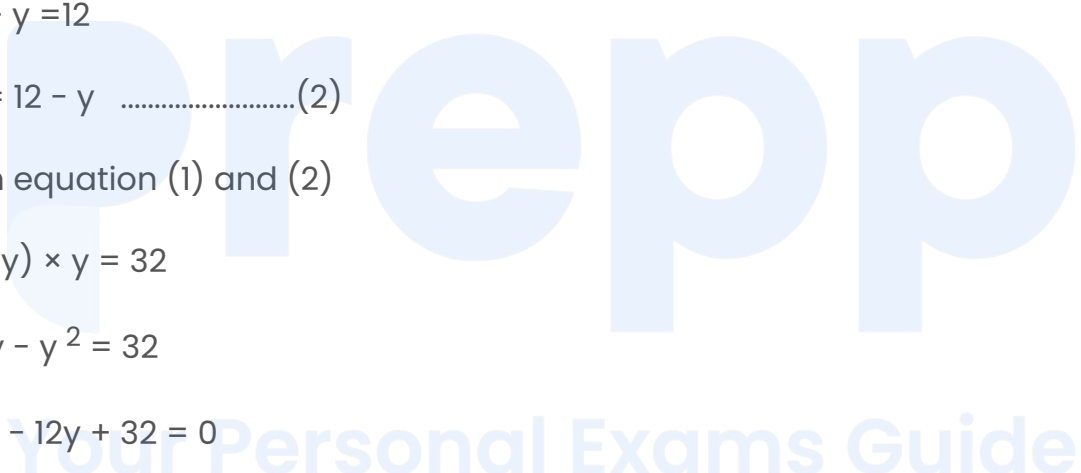

If $y = 4$, Then $x = 8$

$$\Rightarrow (8)^3 + (4)^3 = 576$$

\therefore The sum of cube of these number will be 576.

The correct option is 2 i.e. 576

138. Answer: a

Explanation:

Given:

ABCD is a quadrilateral

Concept:

Tangent drawn from an external point to a circle are equal

Calculation:

$$DR = DS \quad \dots\dots\dots(1)$$

$$RC = CQ \quad \dots\dots\dots(2)$$

$$BP = QB \quad \dots\dots\dots(3)$$

$$PA = AS \quad \dots\dots\dots(4)$$

By adding equations (1), (2), (3) and (4)

$$\Rightarrow DR + RC + BP + PA = DS + CQ + QB + AS$$

$$\therefore AB + CD = AD + BC$$

The correct option is 1 i.e. $AD + BC$

139. Answer: c

Explanation:

Concept:

The maximum value of $a \sin x + b \cos x = \sqrt{a^2 + b^2}$

Calculation:

The maximum value of $\sin \theta - \cos \theta = \sqrt{1^2 + (-1)^2} = \sqrt{2}$

Hence, the maximum value is $\sqrt{2}$.

140. Answer: d

Explanation:

Given:

Number of workers = 21

Days = 25

New workers deployed = 14

Workers after new Joinings = $14 + 21 = 35$

Formula Used:

$(\text{Workers}_1 \times \text{Days}_1) / (\text{Work}_1) = (\text{Workers}_2 \times \text{Days}_2) / (\text{Work}_2)$

Calculation:

$(21 \times 25) / 1 = (35 \times \text{Days}) / 1$

By cross multiplication:

⇒ Days = 15

∴ After deploying 14 new workers work will be done in 15 days.

The correct option is 4 i.e. 15 days

141. Answer: b

Explanation:

Concept:

- Tangent forms a right angle with the radius of the circle at the point of tangency.
- The angle subtended by an arc at the centre is twice the angle subtended at the circumference.

Calculation:

Here, $\angle PAO = \angle PBO = 90^\circ$ because a tangent forms a right angle with the radius at the point of tangency.

Now, In quadrilateral OAPB, we have

$$\angle AOB + \angle APB = 180^\circ$$

$$\Rightarrow \angle AOB + 30^\circ = 180^\circ$$

$$\Rightarrow \angle AOB = 150^\circ$$

$$\text{Now, } \angle AOB = 2\angle AQB$$

$$\Rightarrow 150^\circ = 2\angle AQB$$

$$\Rightarrow \angle AQB = 75^\circ$$

142. Answer: c

Explanation:

Concept:

A probability is a chance of prediction. The formula of the probability of an event is given by

Calculation:

Favorable outcomes of getting 4 or less than 4 = $\{1, 2, 3, 4\} = 4$

Total number of outcomes = 6

\therefore Probability = $4/6 = 2/3$

Hence, the probability of getting 4 or less than 4 is $\frac{2}{3}$.

143. Answer: a

Explanation:

Given:

Radius of semicircle = 3 cm

Formula Used:

Area of the largest triangle inscribed in a semi-circle = $(\text{Radius})^2$

Calculation:

Area of the largest triangle inscribed in a semi-circle = $(\text{Radius})^2$

Area of the largest triangle inscribed in a semi-circle = $(3 \text{ cm})^2$

Area of the largest triangle inscribed in a semi-circle = 9 cm^2

The area of the largest triangle inscribed in a semi-circle is 9 cm^2

The correct option is 1 i.e. 9 cm^2

★ Alternate Method

Given:

Radius of semicircle = 3 cm

Formula Used:

Area of triangle = $\frac{1}{2} \times \text{Base} \times \text{Height}$

Diameter = $2 \times \text{Radius}$

Calculation:

In a semicircle diameter is the base of the triangle

The base of triangle = Diameter of the semicircle

Diameter = $2 \times 3 = 6 \text{ cm}$

The base of the triangle = 6 cm

Height of the triangle = Radius of the circle

Height of the triangle = 3 cm

Area of the triangle = $\frac{1}{2} \times 6 \text{ cm} \times 3 \text{ cm} = 9 \text{ cm}^2$

The area of the largest triangle inscribed in a semi-circle is 9 cm^2



In a semicircle diameter is the base of the triangle.

In a semicircle radius is the height of the triangle.

Triangle drawn in a semicircle is a right-angled triangle.

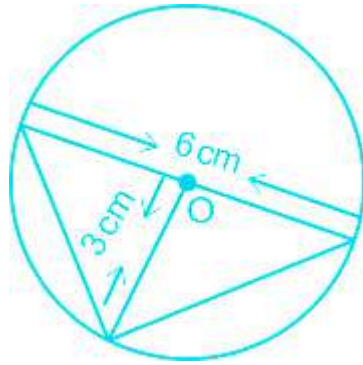

144. Answer: c

Explanation:

Formula used:

$$(a + b)^2 = a^2 + 2ab + b^2$$

$$(a - b)^2 = a^2 - 2ab + b^2$$

Calculation:

Let,

$$y = \sqrt{x + 2\sqrt{x-1}} + \sqrt{x - 2\sqrt{x-1}}$$

$$\Rightarrow y = \sqrt{x - 1 + 2\sqrt{x-1} + 1} + \sqrt{x - 1 - 2\sqrt{x-1} + 1}$$

$$\Rightarrow y = \sqrt{(\sqrt{x-1})^2 + 2 \cdot 1 \cdot \sqrt{x-1} + 1^2} + \sqrt{(\sqrt{x-1})^2 - 2 \cdot 1 \cdot \sqrt{x-1} + 1^2}$$

$$\Rightarrow y = \sqrt{(\sqrt{x-1} + 1)^2} + \sqrt{(\sqrt{x-1} - 1)^2}$$

$$\Rightarrow y = \sqrt{x-1} + 1 + \sqrt{x-1} - 1$$

$$\Rightarrow y = 2\sqrt{x-1}$$

We can see that, when $1 < x < 2$,

Value of $x - 1$ is positive

Hence, option 3 is correct.

145. Answer: d

Explanation:

Calculation:

$$x = 23.\overline{43} = 23.4343\dots \quad \text{-----(1)}$$

On multiplying equation (1) by 100, we get

$$100x = 2343.4343\dots \quad \text{-----(2)}$$

On subtracting equation (1) from (2), we get

$$100x - x = 2320$$

$$\Rightarrow 99x = 2320$$

$$\Rightarrow x = \frac{2320}{99}$$

Hence, The number $23.\overline{43}$ in the form $\frac{p}{q}$ (p, q are integers, $q \neq 0$) is $\frac{2320}{99}$.

Your Personal Exams Guide

146. Answer: d

Explanation:

Given:

$$\text{Marked Price} = \text{Cost Price} + 30\%$$

$$\text{Selling Price} = \text{Marked Price} - 30\%$$

Formula Used:

$$\text{Loss\%} = \frac{\text{Loss}}{\text{Cost Price}} \times 100$$

Loss = Cost Price - Selling Price

$$\text{Discount\%} = \frac{\text{Discount}}{\text{Marked Price}} \times 100$$

Discount = Marked Price - Selling Price

Calculation:

Let assume that cost price = Rs. 100

⇒ Then Marked price = 100 + (30% of 100) = Rs. 130

⇒ So, Selling price = 130 - (30% × 130) = Rs. 91

$$\text{Loss} = 100 - 91 = 9$$

$$\Rightarrow \text{Loss\%} = \frac{9}{100} \times 100$$

$$\Rightarrow \text{Loss\%} = 9\%$$

∴ Loss% is 9%

∴ His profit/loss percentage is 9%

Concept used:

★ Shortcut Trick

Loss% when the selling price is the same = $a - b - a \times b/100$

Calculation:

$$\text{Loss\%} = 30 - 30 - (30 \times 30)/100$$

$$= -9\% \text{ (Negative sign indicates the loss)}$$

∴ The loss percentage is 9%.

147. Answer: c

Explanation:

Explanation:

We have $(x - a)(x - b)(x - c) \dots (x - y)(x - z)$

$\Rightarrow (x - a)(x - b)(x - c) \dots (x - x) \dots (x - z)$

$\Rightarrow (x - a)(x - b)(x - c) \dots (0) \dots (x - z)$

$\Rightarrow 0$

Since it is a zero polynomial. So, the degree would be undefined.

Hence, The algebraic expression $(x - a)(x - b)(x - c) \dots (x - y)(x - z)$ will have the degree undefined.

148. Answer: b

Explanation:

Concept:

The quadratic equation having roots (α, β) is $x^2 - (\alpha + \beta)x + \alpha\beta = 0$.

- The sum of the roots of a quadratic equation is $\alpha + \beta = -b/a = -$ Coefficient of x / Coefficient of x^2 .
- The product of the roots of the quadratic equation is $\alpha\beta = c/a =$ Constant term / Coefficient of x^2 .

Calculation:

The given equation is $x^2 - px + r = 0$ and its roots are α and β

$\Rightarrow \alpha + \beta = p$ -----(1)

Also, $\alpha\beta = r$ -----(2)

Now, $x^2 - qx + r = 0$ and its roots are $\frac{\alpha}{2}, 2\beta$

$$\Rightarrow \frac{\alpha}{2} + 2\beta = \frac{-(-q)}{1} = q$$

$$\Rightarrow \frac{\alpha + 4\beta}{2} = q$$

$$\Rightarrow \alpha + 4\beta = 2q \quad \text{-----(3)}$$

Also, $\frac{\alpha}{2} \times 2\beta = r$

$$\Rightarrow \alpha\beta = r \quad \text{-----(4)}$$

On subtracting equation (1) from (3), we get

$$3\beta = 2q - p$$

$$\Rightarrow \beta = (2q - p)/3$$

On substituting this value in equation (1), we get

$$\Rightarrow \alpha = p - (2q - p)/3$$

$$\Rightarrow \alpha = \frac{2}{3}(2p - q)$$

On substituting the values of α and β in equation (4), we get

$$r = \frac{2}{3}(2p - q) \times \frac{1}{3}(2q - p)$$

$$\Rightarrow r = \frac{2}{9}(2p - q)(2q - p)$$

149. Answer: d

Explanation:

Concept:

$$\sin(A + B) = \sin A \cos B + \cos A \sin B$$

$$1 \leq \sin \theta \leq 1$$

$$1 \leq \cos \theta \leq 1$$

$$\sin (\pi/3) = \sqrt{3}/2 \text{ and}$$

$$\cos (\pi/3) = 1/2$$

Note: $\sin \theta$ is **odd** function and $\cos \theta$ is **even** function i.e.

$$\sin (-\theta) = -\sin \theta$$

$$\cos (-\theta) = \cos \theta$$

Calculation:

Given that,

$$\sqrt{3} \cos \theta + \sin \theta = A$$

$$\Rightarrow 2\left[\frac{\sqrt{3}}{2} \cos \theta + \frac{1}{2} \sin \theta\right] = A$$

$$\Rightarrow 2\left[\sin\left(\frac{\pi}{3}\right) \cos \theta + \cos\left(\frac{\pi}{3}\right) \sin \theta\right] = A$$

$$\Rightarrow 2\left[\sin\left(\frac{\pi}{3} + \theta\right)\right] = A$$

We know that,

$$1 \leq \sin \theta \leq 1$$

$$\Rightarrow -2 \leq 2\left[\sin\left(\frac{\pi}{3} + \theta\right)\right] \text{ or } A \leq 2$$

Hence, from the given options, only $A = 0$ is lying on the given range $[-2, 2]$.

Therefore, option 4 is correct.

★ **Additional Information**

$$2\left[\sin\left(\frac{\pi}{3} + \theta\right)\right] = 0$$

$$\Rightarrow \theta = -\pi/3$$

Check:

$$\therefore \sqrt{3} \cos \theta + \sin \theta = A$$

$$\Rightarrow \sqrt{3} \cos (-\pi/3) + \sin (-\pi/3) = A$$

$$\Rightarrow \sqrt{3} \cos (\pi/3) - \sin (\pi/3) = A$$

$$\Rightarrow \sqrt{3}(1/2) - (\sqrt{3}/2) = A$$

$$\Rightarrow A = 0$$

150. Answer: a

Explanation:

Concept:

The frequency of any class interval is calculated by subtracting the preceding cumulative frequency from the cumulative frequency of that class interval.

Calculation:

Marks obtained	Number of students (c.f.)	Frequency
0 - 10	3	3
10 - 20	7	$7 - 3 = 5$
20 - 30	13	$13 - 7 = 6$
30 - 40	16	$16 - 13 = 3$
40 - 50	21	$21 - 16 = 5$
50 - 60	27	$27 - 21 = 6$

Now, the frequency of class interval 20 - 30 is p

$$\Rightarrow p = 6$$

Also, the frequency of class interval 40 - 50 is q

$$\Rightarrow q = 5$$

$$\therefore p - q = 6 - 5 = 1$$

Hence, the difference of p and q is 1.

prepp

Your Personal Exams Guide